



Work-in-Progress Workshop Proceedings
ACM SIGCHI Tangible, Embedded and Embodied Interaction 2011

January 23, 2011
Madeira, Portugal

Proceedings Editors: Ellen Yi-Luen Do (Georgia Tech, USA)
Mark D. Gross (Carnegie Mellon University, USA)
Ian Oakley (University of Madeira, Portugal)

Cover Design: Mayur Karnik (University of Madeira, Portugal)

Back Cover Photo: Antonio Gomes (Carnegie Mellon University, USA / University of Madeira, Portugal)

Table of Contents

- **Introduction: Work-in-Progress – Tangible, Embedded and Embodied Interaction**i
- **In Transit: Roam and Apparent Wind interaction design concepts**.....1
Teresa Almeida (LASALLE College of the Arts)
- **The Milkscanner**.....7
Friedrich Kirschner (Independent Researcher)
- **Ambient Storytelling: The Million Story Building**.....13
Jennifer Stein, Scott S. Fisher (USC School of Cinematic Arts)
- **Interactive Blossoms**.....19
Shani Sharif, Martin L. Demaine (Massachusetts Institute of Technology)
- **“Assertive” Haptics for Music**.....25
Bill Verplank, Edgar Berdahl (Stanford University)
- **Pleistocene interactive painting**.....31
Koji Pereira (Federal University of Minas Gerais), Vivian Teixeira Fraiha, Fabiane Niemeyer Esposel de Mello, Thássia Fátima Lara (PUC Minas Museum of Natural Sciences), André Veloso Junqueira (Interaction Source), Marcos Paulo Machado (Pontifical Catholic University of Minas Gerais)
- **Delicate Interpretation, Illusion and Feedforward: Three Key Concepts toward Designing Multimodal Interaction**.....37
Kumiyo Nakakoji (Software Research Associates, Inc.), Yasuhiro Yamamoto (Tokyo Institute of Technology), Nobuto Matsubara (Software Research Associates, Inc.)
- **Developing a Tangible Interface for Storytelling**.....43
Cristina Sylla, Pedro Branco, Clara Coutinho (University of Minho)
- **BulletiNet: Mediated Social Touch Interface for Community Awareness and Social Intimacy**.....49
Szu-Chia Lu (Georgia Tech), Andrea Kavanaugh (Virginia Tech)
- **A framework for designing and enhancing serendipitous encounters**.....55
Ken Keane, Jos P. van Leeuwen, Valentina Nisi (University of Madeira)

- **Marking the moment: Coupling NOOT to the situated practice of creative sessions**.....61
 Jelle van Dijk (Eindhoven University of Technology & Utrecht University of Applied Sciences), Remko van der Lugt, (Utrecht University of Applied Sciences), Kees Overbeeke (Eindhoven University of Technology)
- **DUL Radio: A light-weight, wireless toolkit for sketching in hardware**.....67
 Martin Brynskov, Rasmus B. Lunding, Lasse Steenbock Vestergaard (Aarhus University)
- **Towards Collaborative System Based on Tiled Multi-Touch Screens**.....73
 Vít Rusňák, Lukáš Ručka (Masaryk University)
- **Distributed Group Collaboration in Interactive Applications**.....79
 Serge Gebhardt, Christine Meixner (ETH Zurich) Remo Aslak Burkhard (vasp datatecture GmbH)
- **Toward Toolkit Support for Integration of Distributed Heterogeneous Resources for Tangible Interaction**.....85
 Cornelius Toole, Jr., Brygg Ullmer, Kexi Liu, Rajesh Sankaran, Christian Dell, Christopher Branton (Louisiana State University)
- **Designer driven interaction toolkits**.....91
 Walter A. Aprile, Aadjan van der Helm (Delft University of Technology)
- **Tangibles attached to mobile phones? Exploring Mobile ActDresses**.....97
 Mattias Jacobsson, Ylva Fernaeus (SICS)
- **Touchless Multipoint-Interaction on Large Planar Surfaces**.....103
 Dionysios Marinos, Patrick Pogscheba, Björn Wöldecke, Chris Geiger (University of Applied Sciences Düsseldorf), Tobias Schwirten (Lang AG, Lindlar)
- **Performative Gestures for Mobile Augmented Reality Interaction**.....109
 Roger Moret Gabarro (Interactive Institute), Annika Waern (Stockholm University)
- **TEI 2011 Bodies, boogies, bugs & buddies: Shall we play?**115
 Elena Màrquez Segura, Carolina Johansson (Interactive Institute), Jin Moen (Movinto Fun), Annika Waern (Stockholm University)
- **MagInput: Realization of the Fantasy of Writing in the Air**.....121
 Hamed Ketabdar (Deutsche Telekom Laboratories, TU Berlin), Amin Haji Abolhassani (McGill University), AmirHossein JahanBekam (Deutsche Telekom Laboratories), Kamer Ali Yüksel (Sabancı University)

- **2D Tangible Code for the Social Enhancement of Media Space**.....127
Seung-Chan Kim, Andrea Bianchi, Soo-Chul Lim, Dong-Soo Kwon (KAIST)
- **One-Way Pseudo Transparent Display**133
Andy Wu, Ali Mazalek (Georgia Tech)
- **Eco Planner: A Tabletop System for Scheduling Sustainable Routines**.....139
Augusto Esteves, Ian Oakley (University of Madeira)
- **Virtual Mouse: A Low Cost Proximity-based Gestural Pointing Device**.....145
Sheng-Kai Tang, Wen Chieh Tseng, Kuo Chung Chiu, Wei Wen Luo, Sheng Ta Lin, Yen Ping Liu (ASUS Design Center)
- **Entangling Ambient Information with Peripheral Interaction**.....151
Doris Hausen, Andreas Butz (University of Munich)
- **Tangible User Interface for Architectural Modeling and Analyses**.....157
Chih-Pin Hsiao, Ellen Yi-Luen Do (Georgia Tech), Brian R. Johnson (University of Washington)
- **Laser Cooking: an Automated Cooking Technique using Laser Cutter**.....163
Kentaro Fukuchi (Meiji University), Kazuhiro Jo (Tokyo University of the Arts)
- **Design factors which enhance user perception within simple Lego®- driven kinetic devices**.....169
Emmanouil Vermisso (Florida Atlantic University)
- **Augmented Mobile Technology to Enhance Employee's Health and Improve Social Welfare through Win-Win Strategy**.....175
Hyungsin Kim (Georgia Tech), Hakkyun Kim (Concordia University), Ellen Yi-Luen Do (Georgia Tech)
- **Rotoscopy-Handwriting Prototypes for Children with Dyspraxia**.....181
Muhammad Fakri Othman, Wendy Keay-Bright, Stephen Thompson, Clive Cazeaux (Cardiff School of Art & Design, Univ. of Wales Institute, Cardiff)
- **A Savvy Robot Standup Comic: Online Learning through Audience Tracking**.....187
Heather Knight, Scott Satkin, Varun Ramakrishna, Santosh Divvala (Carnegie Mellon University)
- **Energy Conservation and Interaction Design**.....193
Keyur Sorathia (IIT Guwahati)

Work-in-Progress — Tangible, Embedded and Embodied Interaction

The Work-in-Progress (WiP) workshop at the 2011 Tangible Embedded, Embodied Interaction (TEI) conference provided an opportunity for practitioners and researchers to present concise reports of new findings or other types of innovative or thought-provoking work relevant to the TEI community.

The WiP workshop received submissions about designing, making, studying, exploring and experiencing of projects on tangible, embedded and embodied interaction. It provided a venue to elicit feedback and foster discussions and collaborations among TEI colleagues. Papers were reviewed and selected for presentation at the Work-in-Progress workshop on January 23rd, 2011. Copyright for all material remains with the authors.

The workshop attracted participation from a broad range of disciplines, including all TEI's constituent communities – art and design, architecture and urban living, music and acoustics, industrial design and engineering, cinematic arts, digital media, interactive technology, computer science and artificial intelligence, human-computer interaction, robotics and human-robot interaction, information systems and telecommunications, business, education, science and natural sciences.

Participants hailed from 20 countries: Brazil, Canada, Czech, Denmark, Germany, Greece, India, Iran, Italy, Japan, Korea, Portugal, Singapore, Sweden, Switzerland, Taiwan, Turkey, Netherlands, United Kingdom, and the United States.

This volume includes 33 papers covering a wide spectrum of topics and methodologies. The projects range from the Milk Scanner to Laser Cooking, from Storytelling systems to Robotscopy handwriting, from poetic wind-making to writing in the air, from an eco-planner to musings on energy conservation design, from a Virtual Mouse to tangible mobile phones, from augmented reality to one-way pseudo Transparent Display, from haptic music to multimodal interaction and from distributed collaboration to a sketching in hardware toolkit. In all, you have in your hands a pandemonium of tangible interaction projects.

Enjoy!

Ellen Yi-Luen Do, Mark D. Gross, and Ian Oakley

Funchal, Madeira, Portugal
January, 2011



In Transit: Roam and Apparent Wind interaction design concepts

Teresa Almeida

LASALLE College of the Arts
1 McNally Street
Singapore 187940
teresa.almeida@lasalle.edu.sg

Abstract

In this paper I present a series of concept designs that address modes of ecological transportation: concerned with the urban ecology, these are portable devices design proposals for a public bus and body-devices for bicyclists. Could these promote a better understanding of the urban natural systems and therefore encourage ecological activities within a community? This project refers to ongoing research which aim is to develop engaged and poetic technology-enabled artifacts that might contribute to the adoption of sustainable means of transportation. The following are discussed: a set of devices that intend to provide young riders in a public bus with tools to establish a closer contact with the environment and wildlife; a collection of body-devices designed for bicyclists that are accessories which reveal the wind catch while roaming about.

Keywords

Design, Soft Technology, Urban Ecology, Explorations, Work-in-Progress

ACM Classification Keywords

H.5.2. Information interfaces and presentation: User interfaces: Auditory feedback, Haptic I/O and Prototyping

Copyright is held by the author/owner(s).
TEI'11, Work-in-Progress Workshop
Jan 23, 2011, Madeira, Portugal.

Introduction

At the moment, this research project comprehends Roam and Apparent Wind. Roam is the first of the two concept design proposals and it was initiated in 2009. It consists of a set of devices that intend to provide young riders in a public bus with tools to establish a closer contact with the environment and wildlife. By amplifying the visual and audible surroundings in an informed way, they make possible to draw them closer to the wildlife while in transit. They consist of two devices: one that deals with vision, and one that deals with sound. Both mediate an audio-visual experience with the surroundings through mobile technology. This was a project initiated at the Banff New Media Institute, an art and digital research innovation centre based in the town of Banff, Canada. The second proposal, Apparent Wind, was initiated in 2010 during a residency in the city of Brighton, south coast of Great Britain. It consists of a set of body-devices designed for bicyclists that are accessories that reveal the wind catch while roaming about.

Concept Design Proposal 1: Roam

This project was initiated at the Banff New Media Institute, Banff, Canada. The town of Banff is a UNESCO World Heritage Site located in the Banff National Park, set in the heart of the Canadian Rockies. According to the town's web portal, it is less than 4 km square in size, is surrounded by mountain parkland and wilderness, and the community really does share its space with the wildlife [1]. Banff's public transit system *Roam* is a sophisticated service which comprehends four environmentally conscious hybrid electric buses and which promotes the local wildlife: the wolf, the mountain goat, the grizzly bear, and the elk. They are also equipped with the latest GPS technology that

informs passengers when the next bus will arrive. It also lets you take in the views while roaming around town and gets you to Banff attractions in one ride [8]. Roam design proposals are devices that explore the possibilities to enhance these features by repurposing the existing technology to augment the surrounding wildlife. The devices are social objects available *in situ*, they can be shared and eventually be a trigger for conversation.

Locality and iteration

Roam devices invite users, with a focus on children, to participate in a narrative from which they had been foreclosed [6]. The devices derive from research conducted on Banff's public transit system *Roam*, and are an attempt to enhance the ride's experience, and reinforce children's informed engagement with technology in local settings [7].

Exploring the landscape

Children aged eight to eleven demonstrate an innate drive to explore the nearby world [9], and these devices intend to promote their awareness of the neighborhood and beyond, with a focus on local wildlife. The bus is a moving vehicle that allows for an enhanced bond with the natural world.

Sharing devices

Roam consists of the following two devices: *Device I: to see-through* and *Device II: to hear-through*. *Device I: to see-through* (Figure 1) invites the user to maximize the immediate environment's information. This is a device that supports play, and it's an experiment on perception and optics. It proposes for a closer look of the immediate surroundings when traveling from site to



figure 1. Device I: To see-through. Top left: first prototype. Top right: second prototype. Bottom: third prototype.

site, eventually spotting some of Banff's National Park Wildlife from a concealed and protected position. On site observation revealed that to take in the views is oddly difficult. The vehicle is covered in One Way Vision™, a mesh material with many holes that can be printed onto. This is usually used for advertising purposes, and Roam buses advertise the local wildlife. Though this perforated film is designed to create see-through graphics, it proved to reduce the view from within the bus.

Prototypes

Three prototypes have been designed and two have been tested in context. The initial prototype comprised of straws, foam board and masking tape, and it was an initial investigation on how to see through (the monacle design was preferred by two testers) and the user could hold a handle on the side. The second prototype comprises straws and parts found on a local hardware store. The third is a plastic resin cast of those parts and the straws. For all the mentioned prototypes, the straws are arranged according to the geometry of the mesh, covering the vinyl sticker areas and leaving the holes visible through the straw. The intent is to enhance the field of depth/vision lost when looking out with a naked eye.

Device II: to hear-through (figure 2) amplifies the environment and lets one listen across the bus 'wall'. Aware of its location, it provides the rider with real-time audio that informs if there is wildlife nearby. Banff's wildlife is carefully monitored, and many of the animals carry ear tags or radio collars, which allow for geo-location in real-time. *To hear-through* device proposes to combine location and audibility. What if a grizzly bear would have a sound enabled device embedded in his radio collar? What if one could experience their audibility while roaming about? This device proposes to amplify the audible environment and let one listen through the bus 'wall'. Real-time audio would inform the rider whether any of these animals are nearby and offer the possibility for a chance encounter at a safe distance, the comfort zone that is that mobile vehicle. This prototype is made of rabbit fur available from the local native Indians, and combines soft technology (a fabric sensor) with open source hardware/software (Arduino, GPRS/GPS module for Arduino). The hardware



figure 2. Device II: To hear-through. Initial prototype.

and software have been developed to the extent of getting a GPS location (outdoors, wildlife) on a laptop computer. In order to demonstrate concept, experiments were conducted by using two computers, one placed in a specific location and one attached to the device, a proof-of-concept demonstrated via Skype™ call.

Roam: Device I and Device II Observations

Both devices I and II were tested inside the bus by a seven years old child. The child was explained what these intend to do and that they are still undergoing development, and was then asked to play with the parts available and express her opinions about them. For Device I, the user showed her preference for prototype two, as prototype three was heavier. Though the dimension of the straws used, 3" and 5", were not fully compatible with the dimension of the perforated geometry of the vinyl mesh, the user informed of greater visibility achieved with 3". In order to conduct further testing on its viability as a vision-based interface, developments in the future will include digital fabrication, so to have precise measurements. This technology will also prevent overweight, as lighter materials can apply. For Device II, the user considered it attractive and playful when pressing against the window, at the time only receiving a random sound/music from a computer. Further developments will involve resolving the audio implementation. Feedback from an educator/adult tester suggested that children might find it more gratifying if a set of pre-recorded wildlife sounds are available on a pre-set basis. This will also be taken into consideration.

Concept Design Proposal 2: Apparent Wind

Apparent wind is a collection of body-devices inspired by the British Summer and the windy city of Brighton. It is designed for bicyclists as accessories that reveal the wind catch while roaming about. These body-devices intend to be a poetic representation that give form to the imagination through indirect and abstract transformations [10]. A take on previous project Roam, which was designed for a locality and referred to a means of public transportation, Apparent Wind

continues to investigate how devices can mediate space and communication by and while moving forward. It is a first draft of a design concept for bicyclists, which takes on the city of Brighton, a city on the south coast of Great Britain. It is a cycling town, dedicated to promoting healthy and environmentally friendly travel and cycle lanes are provided across the city, including along the seafront [3]. Apparent Wind is defined as the wind the rider feels somewhere between the true wind (from the side) and the man made wind (from ahead). This resultant wind is known as the 'apparent wind' and will have a speed and apparent wind angle, measured from the direction of travel to the apparent wind angle [2]. The suite uses material innovation and renewable and sustainable energies for the end-design of performative artifacts. These are body-devices which represent or transform when affected by external environmental conditions and do so in a cyclical way: they are slightly unpredictable, just like the weather. Apparent Wind's initial prototypes are body-artifacts that use light to augment the bicyclist's own body and movements. They aim at supporting the interaction between human and computing technologies in a non-screen-based environment - an environment with physical and sensual qualities appealing to our human intuition and adapted to our daily life [4].

Body-Devices

The two wearable prototypes are comprised of faux fur material from a local store, a simple soft circuit made of conductive thread, LEDs (Light Emitting Diode), conductive stretch fabric pom-poms, metal jewelry parts acquired at local Emmaus (secular movement/charity for the homeless), polymorph plastic (smart plastic), and a battery power source. The 'necklace' design was chosen as it is a visible area for

both wearer to display the device on her/his body and the onlookers, who are secondary users that view and interpret the device display during chance encounters with the wearer [5].



figure 3. Top: ManMade Wind; Bottom: True Wind

The two body-devices (figure 3) consist of the following: *ManMade Wind* and *True Wind*. *ManMade Wind* illuminates when in motion and moving forward. This initial prototype introduces a simple visualization metaphor that maps airflow. It is designed according to the idea that when one is riding a bicycle on a completely calm day with no wind, one can feel wind on his/her face and it feels stronger as you pedal faster [2]. A tilt switch consisting of several contact points and a found conductive jewelry plate will ignite an array of LED lights to sparkle. *True Wind* illuminates when in motion and while detecting wind coming from the side. A stroke sensor that consists of a series of pom-poms will respond to that breeze, and will react by moving

gently which as a result will trigger embedded LED lights to sparkle.

Apparent Wind Observations

This initial set was experimented by one female user. She felt comfortable with both devices, and enchanted by the light and use of materials, which she was not familiar with. The 'magical' aspect of it, the soft technology and the illumination, triggered questions about the possibility of having it available at a larger number so more people could use it at the same time. Future plans for this design proposal will include implementation on mandatory accessories for bicycle riding, such as the helmet. Though not of compulsory use in many countries, it is of good practice to wear it and, considering the underlined scope of this project, it will therefore be integrated into the design methodology. Extended participation from onlookers will also be considered.

Conclusions

The intention with both Roam and Apparent Wind projects is to design artifacts that invite young people to use urban transportation responsibly while embracing the environment – either through external devices or body-devices – and having a fun experience. The prototypes developed wish to investigate how devices can mediate space and communication by and while moving forward, with the desire that they can also contribute to the adoption of sustainable means of transportation in an engaging and poetic way. These are interaction design concept proposals that are still at

an early stage. The Work-in-Progress Workshop will open up the ideas for discussion with an interested audience, which can lead to new possibilities and directions.

References

- [1] About Banff, <http://www.banff.ca/visiting-banff/about-banff.htm>.
- [2] About the Greenbird, How it works <http://www.greenbird.co.uk/about-the-greenbird/how-it-works>.
- [3] Brighton & Hove City Council <http://www.brighton-hove.gov.uk/index.cfm?request=c1000145>.
- [4] Diffus, The Climate Dress. <http://www.diffus.dk/pollutiondress/intro.htm>.
- [5] Fajardo, N., Moere, A.V., ExternalEyes: Evaluating the Visual Abstraction of Human Emotion on a Public Wearable Display Device, in Proc. OZCHI 2008.
- [6] Greenfield, A., *Everyware, The dawning age of ubiquitous computing*, Berkeley: New Riders (2006).
- [7] Nardi, B. A., O'Day, V. L., *Information Ecologies, Using Technology with Heart*, Cambridge MA: MIT Press (1999).
- [8] Roam, <http://www.banff.ca/locals-residents/public-transit-buses/roam.htm>.
- [9] Sobel, D., Beyond Ecophobia, <http://www.yesmagazine.org/issues/education-for-life/803>
- [10] Wilde, D. A New Performativity: Wearables and Body-Devices. In Proc. Re:live Media Art History Conference (2009).

The Milkscanner

Friedrich Kirschner

Independent Researcher
31 Stone Ave. #2
Somerville, MA 02143 USA
friedrich@moviesandbox.net

Abstract

The Milkscanner is a novel form of 3D scanning using milk or other household liquids and materials and a simple webcam. The process allows scanning of varying scale objects, including human bodies, faces or action figurines, by generating depth information over time while submerging objects in an opaque fluid.

Keywords

Fluid, 3D, Scanning

ACM Classification Keywords

H5.m. Information interfaces and presentation (e.g., HCI): Miscellaneous. I3.3 Digitizing and scanning.

General Terms

Process Description, Guide, Implementation Examples

Introduction

The Milkscanner is a fast and low-cost process for scanning 3D objects. It also illustrates how basic and common materials, like Tupperware bowls and milk or coffee can be put to use in a computer graphics context. The hands-on approach of the Milkscanner visualizes the underlying algorithms of 3D Scanning for all audiences and replaces the technical nature of virtualizing objects with a sensual experience.

Copyright is held by the author/owner(s).

TEI'11, Work-in-Progress Workshop

Jan 23, 2011, Madeira, Portugal.



figure 1. A white object formed by hand, using diet coke as contrasting liquid.



figure 2. A plastic robot in a tupperware bowl full of milk. On the left, we see the threshold image – all red pixels indicate the object, all the white pixels indicate milk.

Other 3D scanners often use inherently technical and sometimes dangerous utilities like lasers, projectors, rotating plates and so on (see below). Most of these tools are affordable, but require a certain amount of technical proficiency to put together and use complex programming algorithms to create the final result.

The Milkscanner uses household materials that are usually not mentioned in conjunction with computers, like milk, ink, tupperware, coffee or an inflatable pool. In addition, the underlying algorithm is easy to explain and encourages experimentation. It is even possible to follow the process step-by-step without the need for any programming, with simple image processing applications.

Related Work

There are lots of low-cost ways to create virtual representations of real objects. One of the most famous is certainly the D.A.V.I.D. Open-Source, 3D laser scanner [1], that requires a webcam and a line laser to work. Other solutions use a rotating plate and a webcam [2]. Yet another solution is to use a projector and a webcam for structured light scanning [3]. All of these approaches are relatively low cost 3D scanning solutions.

Basic Principle

An object is placed in a cereal bowl (or equivalent) and halfway immersed in an opaque fluid that contrasts well with the color of the object. A camera is placed directly above the cereal bowl pointing down, looking at the immersed object in a 90 degree angle to the surface of the liquid (see figure 1). Each

pixel of the resulting camera image can be analyzed for brightness values. Low brightness values indicate that the pixel represents diet coke (black). High brightness values indicate that it belongs to the object to be scanned (white). The brightness threshold is flipped when working with milk and dark objects. A threshold can be used to separate the pixels belonging to the object from the fluid. This effectively represents a two-dimensional slice of the object at a given level of immersion. Adding a small amount of fluid and making sure that the object stays in place will lead to another slice at a different level of immersion.

These slices can be assembled into a grayscale image, by stacking each individual slice on top of each other while simultaneously coloring the slices in rising grayscale values.

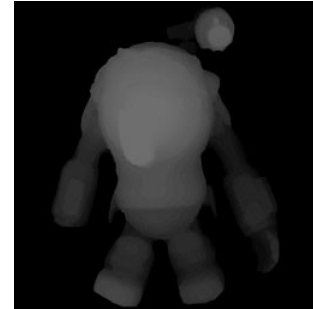

figure 3. The resulting image with depth information encoded into grayscale values. Brighter indicates higher elevation, darker indicated lower elevation.

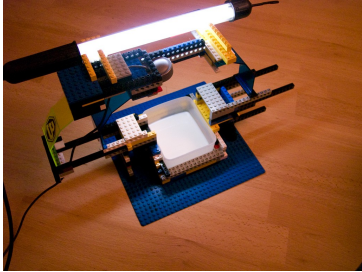

figure 4. The first Milkscanner.

The resulting image represents the elevation of a pixel in any given location as a grayscale value – lighter represents higher and darker represents lower elevation.

It can be saved in any given image format. This file can then be used in software like Autodesk 3D-Studio or Blender to create models using the image file as a Displacement Map.

In addition, a color image can be taken at the start of the scanning process. This can later be combined with the grayscale image for full color and elevation information for any given pixel, using 4 channel image formats (RGB and Alpha) like TARGA.

Implementation

To illustrate the techniques and variations of the process, I describe the following 3 implementations

1) Scanning Action Figures

The first version of the Milkscanner [4], that also gave it its name, was put together using LEGO bricks to build a rig for a Logitech USB webcam that was mounted above a Tupperware bowl in which the to-be-scanned object was placed. Custom software was written to allow for thresholding, image capture and accumulation of layers. The software is freely available at: <http://milkscanner.moviesandbox.net>.

This implementation used a step-by-step approach to scanning with approx. 3 teaspoons of milk for every layer. After adding the teaspoons of milk, a single image was taken and processed and then stacked on top of each other as described before. Figure 3 is the first scanned depth-map using this process.

2) Scanning people

A second implementation focused on the live scanning of humans [5]. A plastic inflatable pool measuring roughly 2 meters in diameter and 1,2 meters deep was filled with (unfortunately cold) water and enough ink was added to turn the water opaque (approx. 0.5 liters). Again, a simple Logitech webcam was placed above the pool. Using a wooden construction to lie on and hold on to, volunteers were manually and slowly immersed into the opaque liquid.

A nose clip was used to prevent the slowly rising water from trickling into people's noses. The actual scanning process took no longer than 15 seconds. People of all skin colors were scanned and results were non distinguishable.

The camera sent live video at 25 frames per second to the milkscanning software. The software then performs brightness thresholding operations on all single frames of the live image, allowing for a continuous realtime scanning process. All slices are then stacked together into a single image while stepping through rising grayscale values. Starting and stopping of the process is controlled manually. A visualization software was created to illustrate the finished scans.



figure 5. Live Human Ink-Scan (Eyebeam Center for Art and Technology, New York, 2008).

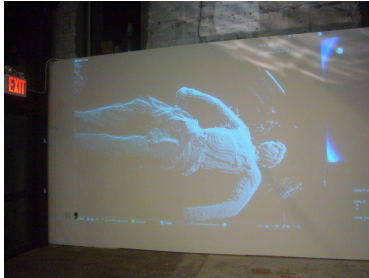

figure 6. Human Ink-Scan Visualization (Eyebeam Center for Art and Technology, New York, 2008).

3) Scanning peoples faces

The final Implementation of the Milkscanner allows for realtime scanning of human faces using coffee beans or peppercorns.

This time, a flat-bottomed approx. 30cm high glass bowl filled with clear water is used. The same camera is placed underneath the bowl looking upwards, with enough distance to record a full image of the bowl's contents. Coffee beans are added on top of the water to float on the water's surface. Intensive testing revealed that washing the coffee beans prior to using them in this configuration greatly decreases the effect of them staining the water.

Participants now 'dunk' their head (face first) into the bowl until it is halfway submerged. While still underwater, they are told to quickly shake off coffee beans that got stuck around the eyes, nose and mouth areas.

In contrast to the first two implementations where the scanning process took place upon submersion, in this version the scanning takes place upon the face exiting the bowl of water.

The scanning begins as the head is slowly raised out of the bowl. The coffee beans form a dark opaque layer, leaving the face in high contrast. The same brightness-threshold image processing is used on a live camera stream to create a grayscale image containing elevation information of a person's face.

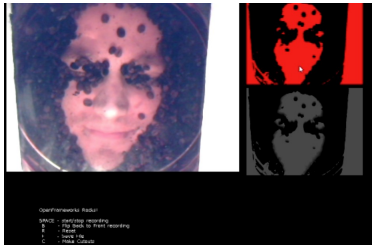

figure 7. Screenshot of the Milkscanning software in its current iteration, while scanning a face. Note the coffee beans stuck around the eyes (Open Design City, Berlin, 2010).

Limitations

The described process has a number of significant limitations in all its described implementations.

Protrusion and obstruction

The most significant limitation is that the milk scanning (also ink and coffee-bean scanning) process only scans objects that are not obstructed from the point of view of the camera. Which means that it usually only scans one 'side' of an object (or person, or head). Multiple passes are needed to scan complex objects.

Contrast

The image processing is using simple thresholding by brightness, which means that high contrast objects, shadows or reflections on the fluid's surface can lead to distorted results. A solution would be to add a combined Chrominance and Luminance Threshold. This would also allow the use of other opaque liquids, such as orange or tomato juice.

Manual Movement and Live Subjects

My Implementation uses basic household objects and therefore its operation relies on manual dexterity. Be it the 3 teaspoons of milk that were used to scan the little plastic robot, the two helpers lowering volunteers into the inflatable pool, or test subjects slowly emerging from a water and coffee-bean filled glass-bowl, the immersion speed has never been linear. For more precise scanning results, a stepper motor can be implemented that controls a steady rate of submersion.

Resolution

The resolution of the Logitech Webcam used in all of the implementations so far is standard VGA, which results in a picture that is 640 pixels wide and 480

pixels high. Confining the elevation information to one 8bit grayscale channel limits the depth resolution to 255 discrete steps.

The first limitation is easily lifted by using a higher resolution camera and changing some basic values in the software implementation. The latter limitation can be evaded by using a separate 4 channel color image with a fixed color order to store depth information. Writing in the Alpha channel first, then using the Red, Blue and finally Green channels, the resulting resolution would create 1020 discrete steps. This could further be expanded upon by using multiple images, or choosing a non-image based form of storing the elevation information.

Non linear displacement of fluid

Adding fluid or lowering the object into it creates a non-linear rise of the fluid in the container. This rise depends on the shape of the scanned object. A solution to this problem would be to use the concept of an infinity pool in which the fluid level stays constant during the scanning process and the object gets lowered.

Lens distortion

The camera used in my implementations has a wide angle lens with visible lens distortion on the edges of the image frame. To evade imprecise scanning, a different camera with a better lens could be used or the software could morph and un-distort the camera image.

Surface tension

The surface tension of milk, ink and water, Cola and other opaque fluids can create distortion in the results, especially when scanning smaller objects and details.

Surface tension can be lowered by adding dishwashing liquid.

Using the Milkscanner in Production

The discussed implementations have been used in a variety of animation productions. "Ein kleines Puppenspiel" (Kirschner, 2007), a live performance using realtime computer graphics based on the video game "Unreal Tournament 2004" (Epic Games, 2004) used an early implementation to create one of the two animated characters.[6]

The production "Verion" (Kahn, Gaude, Kirschner, 2009), a mixed reality theatre piece using 3D stereoscopic projection, live actors and similar realtime animation, used Milkscanning to create all of its virtual characters. Plastic Figurines resembling characters of the popular TV series "Lost" (Lieber, Abrams, Lindelof 2004) were scanned and later repainted.[7]

Students at Queensland Academy of Creative Industries (QACI) use the Milkscanner in conjunction with the software Z-Brush to create virtual terrain.

References

1. Simon Winkelbach, Sven Molkenstruck, and Friedrich M. Wahl, "Low-Cost Laser Range Scanner and Fast Surface Registration Approach", Pattern Recognition (DAGM 2006), Lecture Notes in Computer Science 4174, ISBN 3-540-44412-2, Springer 2006, pp. 718-728. 2006.
2. Agostinho M. Brito Júnior, Luiz Marcos Gonçalves, George Thó, Anderson L. de O. Cavalcanti, "A Simple Sketch for 3D Scanning Based on a Rotating Platform and a Web Camera," sibgrapi, pp.406, XV Brazilian Symposium on Computer Graphics and Image Processing (SIBGRAPI'02), 2002
3. Nivet J.M., Körner K., Droste U., Fleischer M., Tiziani H.J., Osten W., "Depth-scanning fringe projection technique (DSFP) with 3-D calibration", Proc. SPIE 5144 (2003) 443-450
4. Milkscanner Instructable.
<http://www.instructables.com/id/Milkscanner-V1.0/>
5. Inkscanner @ Eyebeam Mixer on Vimeo.
<http://vimeo.com/1190405>
6. A Puppet Play.
<http://puppenspiel.moviesandbox.net>
7. Verion Scene Preview on Vimeo.
<http://vimeo.com/6861889>

Ambient Storytelling: The Million Story Building

Jennifer Stein

Mobile and Environmental Media Lab
USC School of Cinematic Arts
Los Angeles, CA USA
steinjen@usc.edu

Prof. Scott S. Fisher

Mobile and Environmental Media Lab
USC School of Cinematic Arts
Los Angeles, CA USA
sfisher@cinema.usc.edu

Abstract

This paper describes current research towards new approaches for storytelling and context- and location-specific character development. The result of this research is the *Million Story Building* (MSB) project, which has been designed and implemented by the Mobile and Environmental Media Lab in USC's Interactive Media Division. The new School of Cinematic Arts building provides the setting for *ambient storytelling* in which conversations between the building and its inhabitants introduce new ways of interacting with architectural spaces for storytelling.

Keywords

Mobile, Ubiquitous Computing, Ambient Storytelling, Interactive Architecture, Sensors

ACM Classification Keywords

H5.m. Information interfaces and presentation: Miscellaneous

General Terms

Design Document, Work-in-Progress

Introduction

The growing number of ubiquitous and embedded computing technologies introduces a new paradigm for how we interact with the spaces of everyday life.

Copyright is held by the author/owner(s).

TEI '11, Work-in-Progress Workshop

Jan 23, 2011, Madeira, Portugal.

Mobile devices, specifically smart phones, offer new possibilities for sensing and communicating with the physical world around us. As these technologies pervade our everyday interactions, the context and location in which they occur becomes more relevant. These technologies can be used not only for collecting and providing data about the world, but also for engaging people in context- and location-specific ambient stories that encompass everyday life.

The Mobile and Environmental Media Lab explores context- and location-specific mobile and storytelling. Our current research projects focus on interactive architecture within the context of environmental media. Through the use of media technologies, it is our goal to enhance environmental awareness, augment presence in the physical environment, and enable participation in place making. This research investigates the idea of *ambient storytelling* and how the built environment can act as a storytelling entity that engages and interacts with people in specific spaces. Development of personalized responsive/interactive environments arise as people spend time in and build a relationship with the spaces they inhabit habitually. By integrating context-aware interactions and access to backstory about an environment, ambient stories emerge and can be accessed through mobile and pervasive computing technologies and applications.

Approach

Our approach focuses on the social and participatory elements of both ambient storytelling and interactive architecture. The research project described below uses a campus building as both a character and the setting for collaborative, context-specific storytelling in which the building inhabitants become an integral part of the story world. By inviting inhabitants to engage with both the building and other inhabitants, we have introduced a new paradigm for place making within a playful, interactive environment.

Earlier research into lifelogging and backstory further provides a groundwork for thinking about new forms of storytelling. This has progressed into an interest in how these stories could be customized and delivered in specific contexts and locations throughout the day, which we have termed *Ambient Storytelling*. By thinking more deeply about context and location specificity, we have experimented with what a lifelog for an architectural space might be and what backstories the objects within might contain, i.e. what a building would lifelog about, how it would communicate this lifelog to its inhabitants or to other buildings, what kinds of backstories the objects tell, and the stories that might emerge from this buildings' lifelog and backstories.

Ambient Storytelling

The term *ambient storytelling* is used to describe the context-specific and location-specific stories that emerge over time and immerse inhabitants in a story world through daily interactions with a building or architectural space. This form of storytelling within the built environment is enhanced through mutual participation and collaboration between inhabitants and the building as they begin to learn from and interact with one another over time. The development of a personalized responsive environment therefore evolves within the context of one's surroundings, creating a deeper connection and sense of presence within a specific location. For the purpose of our research, ambient storytelling takes place through the use of lifelogs, backstory, sensor networks and mobile devices within the built environment.

The practice of lifelogging, or documenting and broadcasting one's daily activities with wearable computing devices, has been a recurrent topic of our research. However, instead of people documenting their activities, we are focusing on designing lifelogs for the built environment. Lifelogs for physical spaces combine various building, environmental and human sensor data, as well as collaboratively-authored character development, to create an ongoing presence

of a story. Through the integration of these various sensors and collaborative character development, the building itself offers a daily snapshot of both infrastructural behaviors (power and water usage, internal temperature, HVAC usage), but also the behavior of the inhabitants of a building (movement through space, interests in context-specific information, time spent in the building). These elements, when combined, create the groundwork for ambient, mobile storytelling based on contextually relevant information collected and authored throughout the day.

Additionally, backstory, or the extant history of an object or situation, plays a significant role in our conceptualization of mobile and ambient storytelling. By embedding objects with contextual information about what materials objects are made of, where those materials came from, who designed and built the objects, and how the objects were transported, we can deepen the emotional connection of a participant to an object and space. It is our objective to provide a novel way to access an object's backstory using mobile and pervasive technologies and applications, while the overarching goal of our research into ambient storytelling is to merge lifelogging and collaborative character development with these backstories and context-aware interactions.

Finally, this model for ambient storytelling provides a platform for making sensor and environmental data more accessible and playful within the actual context of the information. Rather than simply visualizing the data that is produced and captured throughout the day, this information becomes an ongoing part of the story through both lifelogs and backstory.

The Million Story Building Project

The *Million Story Building* (MSB) project introduces the idea of mobile, ambient storytelling within the new School of Cinematic Arts Lucas Building at the University of Southern California. Through the use of the custom MSB mobile phone-based application, inhabitants and visitors become immersed in an

emergent, responsive environment of collaborative storytelling. By designing location-specific interactions in the built environment, we have created an interface to the new George Lucas Building [School of Cinematic Arts Complex] through the use of mobile phones, sensor networks, and software applications.

This application is intended to be used by the students, faculty and staff of the School of Cinematic Arts on a daily basis. As these inhabitants begin to interact with and engage in conversations with the building regularly, an ongoing relationship develops between the building and its inhabitants. If inhabitants choose to have an active relationship with the building and begin to interact more frequently, the building can create user profiles by learning names, locations and activities of its inhabitants. This user profile can be used by the building to offer context-specific information tailored to the likes and interests of a specific inhabitant. Furthermore, we have designed mission-based experiences and challenges that deliver a daily surprise to individuals as they spend more time in the building and sustain a playful relationship with the building. Experiences such as tagging movie clips, taking photos of specific elements of the building, and collecting videos from film locations are introduced to inhabitants in the form of missions or quests that the building proposes as a way to help it learn about itself, its inhabitants, and the world around it. These requests are made by the building in a pervasive game-like way in which inhabitants are asked to complete more difficult tasks only after becoming actively engaged with the building over time.

Additionally, as inhabitants begin to interact with the building and provide the requested information, a digital archive of all the collected videos, images, tagged movie clips and other data is created. The resulting database for this collected data will be useful to the School of Cinematic Arts not only as a way of developing a living history of the new Lucas building, but will also provide useful tools that can be used in the classroom. For example, as more movie clips are collaboratively tagged, professors and students will be

able to access the database and call up movie clips by keyword in the classroom. Having access to the kinds of information that the building collects and stores will be an invaluable resource to the School of Cinematic Arts.

The Million Story Building project has allowed us to explore new ways of interacting with the built environment, as well as to think about the process of place-making in computationally embedded spaces. By embedding a digital layer of information into an existing building, we have created a new kind of space for storytelling in which a mobile phone application invites users participate in a persistent story world. This current research and development will inform our future design plans for the new Interactive Media building. Our goal for the new building is to embed interactive systems and backstory elements from the ground up at the beginning of the design and construction process.

Million Story Building Mobile Interface

The current mobile phone application provides a voice to the building through its lifelog, as well as a toolset for inhabitants to explore, collaborate/participate, and communicate with the building. Below is a description of the various tools included in the mobile application:

Twitter

Twitter acts as a Lifelog for the building. The building uses its Twitter stream to update its inhabitants of various activity in and around the building. When the mobile application is launched, the Twitter stream is visible and is the first interaction a user has with the building each day. The building might share information about when its plants need watering, who has recently entered the building and launched their mobile application, when someone is interacting with the building or QR codes, and the mood of the building and its inhabitants.

Twitter is also used by the building to emerge as a

character, first by providing information about building infrastructure, then slowly developing into more personalized and context specific information as it begins to learn more about the world around it and the people who use it.

Flickr

The camera can also be used by inhabitants and guests to take photos around the building, which are directly uploaded to Flickr. The building might send requests to users to take photos of certain objects or attributes within the building. A database of photos is created and might show changes to the building over time. The photos are also accessible for viewing on the Flickr page within the application and can give the building and its users a real-time perspective of what is happening in the building.

QR Code Reader/Scanner

The camera can be used as a Quick Response, or QR reader to discover information embedded within the buildings' walls. When a QR code is discovered in the building, inhabitants can take a picture of that QR code and will receive contextual information related to the location of that QR code, i.e. movie poster, faculty office. Many of the movie and game posters in building will have a QR code that links to information such as alumni interviews, movie trailers, movie stats, and reviews.

MovieTagger

When the building begins to recognize that certain users are actively engaged with the building, it will ask users for help in defining and tagging certain movie clips with keywords. For example, when a user accesses certain movie/game poster QR codes, certain information about that movie/game will be immediately available. Over time, the building might ask its users to find a plasma screen within the building and help tag a movie clip or series of movie clips. When the user approaches a plasma screen, the plasma display will sense that the user is within range and will ask a

question and play a movie clip related to the poster whose QR code was accessed earlier. As the user begins to interact with the building and respond to its requests, the building will develop a stronger relationship with that user and will begin to ask for more help. In addition, this application enables users to collaboratively create a robust annotated clip library for the School of Cinematic Arts, in which students and professors will be able to access for classroom use at any time.

Sensor Information

Sensor data from both sensors in the phone and within the building is visualized and can be viewed within the application. By accessing the sensor tool, users can see information such as personal pedometer steps, human movement through the building, building information modeling data, and environmental data.

Plasma Displays

The plasma displays located throughout the building broadcast RSS feeds from the SCA Community website, the Interactive Media Division website, and other information about what is happening around the building. These displays also provide a platform for interaction between the building and its inhabitants by broadcasting missions that establish new social interactions between inhabitants themselves as well as between inhabitants and the building.

Provenance (Story Objects)

Objects within the building, in addition to the building itself, are embedded with a backstory and contextual information. These objects can tell stories about the materials they are made from, where those materials came from, and who made the objects. These objects

contain QR codes, bluetooth proximity sensors or AR applications and will alert the inhabitants to information that is available within them. Furthermore, inhabitants can embed additional information into the objects or the building, creating an ongoing digital archive for the objects and the building.

Digital Story Archive

The statue of Douglas Fairbanks and the courtyard at the entrance to the Lucas Building will act as a story repository, where users can engage with stories that have been left there in addition to leaving their own stories behind. When a user scans the courtyard with their camera tool, a number of story bubbles will be generated from stories that have been left there. Each bubble links to a story which can be opened and read by the user. The user then has the option to leave their own story behind as well.

Navigation

A number of pedestals with AR markers will be located throughout the building. When a user scans the AR marker with their camera, they will see a 3 dimensional model of the floor they are on, as well as information about how to locate specific places on that floor.

Alternatively, there will be a map tool that will allow users to flip to a 3 dimensional representation of the floor they are on and find out where specific classrooms, offices or departments are located.



figure 1. Mobile Interface for Million Story Building.

Future Directions

It is our goal to extend this ongoing research for new contexts and locations. We are currently considering other ideal application spaces to expand this kind of project to, such as children's hospitals and museums. Additionally, we believe this model for interaction presents new possibilities for making buildings and inhabitants engage in more environmentally sustainable practices by changing harmful behaviors and encouraging helpful solutions. This approach can be adopted and integrated from the onset of new architectural projects by using the sensor networks and information collection and processing within existing Building Information Modeling and Building Management Systems to help change behavior and extend the lifecycle of buildings.

Citations

[1] See Steve Mann's early research on lifelogging <http://wearcam.org/steve.html>; and Gordon Bell's work at Microsoft with SenseCam/My LifeBits: <http://research.microsoft.com/en-us/projects/mylifebits/>

Acknowledgements

We would like to thank the researchers of the Mobile and Environmental Media Lab in the Interactive Media Division, School of Cinematic Arts at the University of Southern California. The MEML team includes Scott Fisher, Jen Stein, Jeff Watson, Josh McVeigh-Schultz, Marientina Gotsis, Peter Preuss, and Andreas Kratky. We would also like to thank Intel and Nokia for their generous support.

Interactive Blossoms

Shani Sharif

Massachusetts Institute of
Technology (MIT)
Design and Computation Group,
Department of Architecture
77 Massachusetts Ave.
Cambridge, MA 02139
sharif@mit.edu

Martin L. Demaine

Massachusetts Institute of
Technology (MIT)
Computer Science and Artificial
Intelligence Laboratory
32 Vassar St.,
Cambridge, MA 02139
mdemaine@mit.edu

Copyright is held by the author/owner(s).
TEI'11, Work-in-Progress Workshop
Jan 23, 2011, Madeira, Portugal.

Abstract

Interactive Blossoms is an interdisciplinary project that integrates ideas derived from interactive behaviors in natural organisms with the art of paper folding, especially deployable origami. The flower-like deployable origami models imitate blooming of plants in nature. In this project, the origami models are equipped with electronic parts to present responsive behaviors to the movement and touch of users in the environment. This paper explores the role of design considerations for physical and kinetic parts in interactive structures through the development of an interactive panel.

Keywords

Interactive surfaces, origami, deployable origami, biomimicry, naturally inspired design, wrapping fold pattern

ACM Classification Keywords

H5.m. Information interfaces and presentation (e.g., HCI): Miscellaneous.

Introduction

The research on interactive artifacts and environments engages some of the state of the art studies in the fields of science, engineering and art. This area of research can benefit from the study of the natural environment in which animals and plants have evolved

interesting interactive responses to changes in their surroundings. Biochemical emission of light by fireflies, change of color in chameleons, or fold of leaflets in response to touch in sensitive plants, are examples of different reactions in living organisms as means of survival. Many of these tangible or visual interactions in natural organisms can provide designers and engineers who are researching toward the development of interactive processes, environments and products, with a source of inspiration. In this regard, this research focuses on the development of a physical interactive panel, Interactive Blossoms, which takes advantage of the ideas derived from botanical studies. Interactive Blossoms has been inspired by the rotational movement of morning glory blooms and the reaction of sensitive plants, *Mimosa pudica*, to touch.

Moreover, this research presents how the meticulous design of mechanical and kinetic parts in a physical-interactive project results in the simplification of computing and electronics, while providing an equally interesting outcome for the users. Consequently, this paper proposes origami models as suitable systems for interactive structures, and specifically focuses on three dimensional deployable origami forms.

First, the paper explains the selection process of the most appropriate deployable origami form that resembles the rotary motion of blooming in this project. On the next step, the selection of two-dimensional sheet material and its effects on the fabrication process is discussed. And finally, the paper presents a novel method to facilitate the actuation of the deployable model with servomotors and infrared (IR) sensors.



figure 1. Sensitive plant reaction to touch [6]



figure 2. Rotary motion of Morning Glory blooming [6]

Deployable Origami

Origami, the ancient Japanese art of paper folding, relies on a specific quality of paper, structural memory. Origami artists and scientists use this special quality to create different sculptural and structural forms. Although most of the origami models have been designed to hold a folded form, there are some instances of origami that can be folded and unfolded many times. These deployable origami models are utilized in different fields such as architecture, engineering and art.

The current research explores different deployable origami forms, which have potential qualities that make them suitable to be incorporated in an interactive panel, imitating the kinetics and responsiveness of plants and flowers in nature.

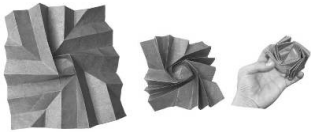

figure 3. Simple Flasher, Jeremy Shafer [8]



figure 4. Origami Spring, Jeff Beynon [7]



figure 5. Flower Tower, Chris Palmer [5]



Figure 6. Eyeglass, foldable space telescope, Robert Lang [3]

The first model that was studied in this research was selected from a group of origami known as action origami, including familiar models such as the flapping bird model. Flashers, designed by Jeremy Shafer, are collapsible models that can be expanded rapidly [6] (Figure 3). Although some Flashers have very complex patterns, the simple Flashers have some qualities, making them suitable for the current project: the ease of expansion, the simplicity of folding and the small size of the folded model.

Next, the origami Spring, created by Jeff Beynon, was explored. It consists of a number of rings, which are twisted around the central axis of the spring (Figure 4). This model presents a fascinating kinetic behavior: it expands along its axis when the rings are pressed. However it is very difficult and time consuming to fold into spring form.

One of the most elaborate examples of deployable origami models is Flower Tower, designed by Chris Palmer (Figure 5). This advanced origami model is created based on a recursive and multi-tiered geometric pattern. As a collapsible model, the different levels of this tower can pop up by twisting around the central axis [5]. However, it is very difficult to actuate this model with simple mechanical and electromechanical devices as a part of an interactive installation, because of the complexity of the fold pattern.

Deployable origami models besides their aesthetic and artistic features can also be designed for engineering purposes. One of the studied models from this group, Eyeglass, was designed by renowned origami artist and theorist Robert Lang to function as a foldable space

telescope (Figure 6). This disk-shape foldable telescopic lens is designed to can be carried with space shuttle and be folded in the space to form a lens with cylinder shape [3].

Another genre of related research involves combining origami with robotics. Matthew Gardiner in his installations, Oribatics, integrates computer-controlled mechanics with folded paper models (Figure 7). The flower-like paper models in these installations, equipped with audiovisual effects, react to the visitors' movement. However, the complexity of origami patterns, which is used in these robotic paper flowers, makes the mechanical actuation difficult. The result is complex mechanical parts and details as well as slow kinetics of the flowers.



figure 7. Oribatics, Matthew Gardiner [4]

Having explored different origami models, it can be concluded that the desired criteria for an origami model to be incorporated in the Interactive Blossoms project are: 1.fewer number of folds to facilitate the fabrication and maintenance process, 2.rotary kinetic pattern to mimic the blooming of natural flowers, 3.ease of actuation with simple electromechanical devices such as servomotors [1].

Wrapping Fold Pattern

After studying different deployable origami models and their applications in interactive projects, the Wrapping



figure 8. Wrapping Fold Pattern tends to fold inward

Fold Pattern has been selected as the origami flower models for the Interactive Blossoms project. This pattern offers an interesting and yet relatively simple method for folding a thin disk-shape membrane around a hub. Simon Guest from the University of Cambridge has developed the Wrapping Fold Pattern, based on some earlier instances of this model.

The wrapping fold pattern consists of an n -sided polygon shape hub, and a set of hill and valley fold lines diverging from each corner of the polygon. Folding the two-dimensional membrane along these lines results in a three-dimensional form, which tends to fold inward and wrap around the hub, forming a right prism. The hub preserves its flatness in the folding process. In this model the polygon should have even number of sides to maintain the sequence of hills and valleys in major folds (major folds are shown with black lines in Figure 8).

Guest in his paper describes the wrapping fold models in two different conditions: first with a simplifying assumption that the membrane has zero thickness, and second, an extended version of the pattern for a membrane with a thin thickness. In the model for zero thickness membrane, the major folds consist of collinear segments; while these segments in the model for a thin thickness membrane are not collinear and they make an angle with each other, which is defined, based on the thickness of membrane (Figure 9).

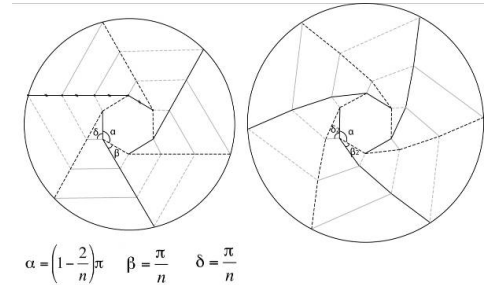

figure 9. Geometric model of Wrapping Fold for zero-thickness (left) and thin-thickness (right) membranes

Design, Material and Fabrication

The development of the final physical model was the result of a series of experiments with geometry, form, material, and kinetics.

Geometry of Kinetics

The first step in the fabrication process was to determine the size of the hub and number of the major folds, which consequently determines the height of the folded model (Figure 11). Through experiments with physical models, a 16-sided polygon as the hub for the final prototype was selected.

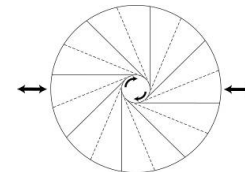

figure 10. The Wrapping Fold with a 12-sided hub

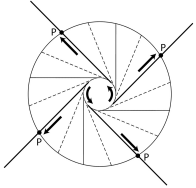

figure 12. The kinetic of the Wrapping Fold: the fold is fixed at points P to the guiding wires

This model was specifically advantageous in the actuation process. In the former examples of the wrapping fold, the models are wrapped around the hub with force that is applied to the outer edge of the disk as shown in figures 8 and 10. However, experiments with the fabricated model revealed that while the hub is turning around its central point, the outer vertices of the major folds (Marked with P in figure 12) move on straight lines. This fact has been used in the fabrication of the final model. In this models when the four of the vertices of the major folds are confined to guiding lines, the rotation of hub results in folding and unfolding of the model.

Material Selection

An important issue in the fabrication of this interactive project is the selection of material for the deployable origami parts, as these origami flowers are in constant deformation when users try to interact with this origami blossoms. The material used for these flowers should be thin, flexible, durable, and should have structural memory to hold the fold creases. However, the experiments with normal origami papers proved that these papers or the similar types are not suitable as they tear after a number of folding and unfolding.

The result of experiments with different types of materials for these origami flowers led to the selection of book-cloth, a flexible and durable material, which is used in bookbinding. The book-cloth, selected for this project, is a paper-backed heavy-duty fabric in which the laminated paper can hold the creases of the fold pattern, while the fabric prevent the model from tearing.

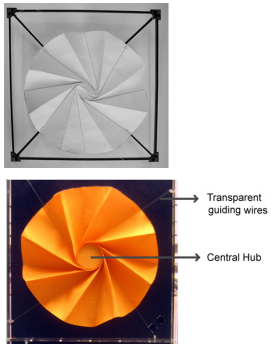

figure 13. Fabricated models of the Wrapping Fold, top: experimental model, down: final model

Embedding Electronics

The final prototype of the Interactive Blossoms consists of a two by five grid of deployable flowers. Each flower is equipped with a Parallax (Futaba) Standard Servo, which precisely holds any position between 0 and 180 degrees with no backlash. These servos, which are mounted behind back panel of the origami flowers, are connected with a series of custom designed and digitally fabricated gears and a shaft to the hub of the paper models.

Each pair of these servos simultaneously reacts to users' movement and their distance to the model by analog input received from infrared sensors (Sharp IR Sensor GP2Y0A02), which measure distance ranging from 20 to 150 cm. These ten servos and five IR sensors are controlled with an Arduino Mega microcontroller board.

The retraction of the deployable flowers has an inverse ratio to the distance of users from the models. Based on the information from IR sensors, the flowers are folded when the users get close or try to touch them.

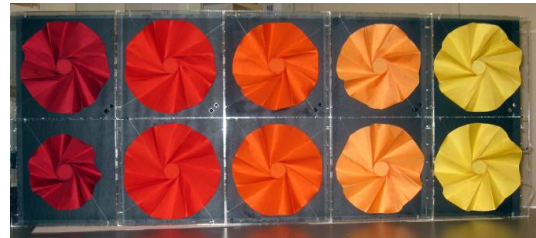

figure 14. Final prototype of Interactive Blossoms



figure 16. The gear system for actuation of the flowers with servomotors

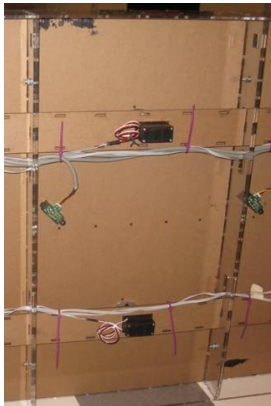

figure 17. Back of the panel, showing IR sensors and servomotors

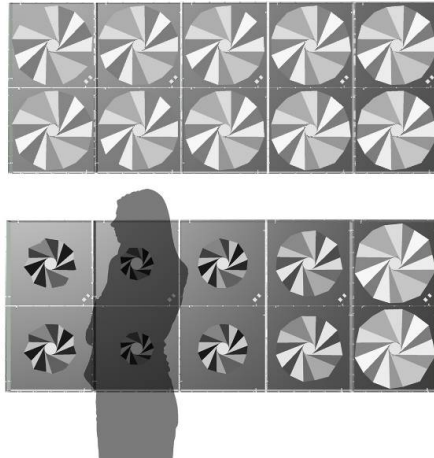

figure 15. Interactive Blossoms' interaction to users

Conclusion

This paper presented an interdisciplinary design process for Interactive Blossoms, a responsive panel with flower-like origami models. In this project, the ideas that were derived from intelligent interactions in natural organisms were combined with deployable origami models, digital fabrication techniques, computing and electronics. The precise design of the physical kinetics in this project resulted in the simplification of the electronic and computation parts.

At the moment, this project acts as an art-entertainment project; however different functions for this prototype is perceivable by some modifications in the shape of the origami models and change is the type of sensors. For example, by using square shape origami

models along with sensors such as light and temperature, Interactive Blossoms can be utilized as an ideal interactive shade for building façades or interior spaces.

Acknowledgements

This project is funded (in part) by the Director's Grant from the Council for the Arts at MIT.

The authors would like to thank Erik Demaine from MIT CSAIL, Simon D. Guest from University of Cambridge and Orkan Telhan from MIT Design and Computation group for their comments in the development of this project.

References

- [1] Gardiner, M. *Oribatics* <http://www.oribotics.net/>
- [2] Guest, S.D., Pellegrino, S. Inextensional Wrapping of Flat Membranes. In *First International Conference on Structural Morphology, Montpellier (1992)*, 203-215. <http://www2.eng.cam.ac.uk/~sdg/preprint/Wrapping.pdf>
- [3] Heller, A. A Giant Leap for Space Telescopes. *Science & Technology Review Magazine* (2003), 12-18. https://www.llnl.gov/str/March03/pdfs/03_03_2.pdf
- [4] Oribotics [.de]. *Airstrip website*. [http://www.airstrip.com.au/art/Oribotics_\[.de\]](http://www.airstrip.com.au/art/Oribotics_[.de])
- [5] Palmer, C.K. *Flower Towers*. Shadowfolds <http://www.shadowfolds.com/>
- [6] Science Photo Library. <http://www.sciencephoto.com/>
- [7] Trumbore, B. *Spring Into Action* <http://trumbore.com/spring/>
- [8] Shafer, J., Palmer, C. *Iso-Area Flasher*. <http://www.barf.cc/FlasherIsosimp.pdf>

“Assertive” Haptics for Music

Bill Verplank

CCRMA
Stanford University
Stanford, CA 94305 USA
verplank@ccrma@stanford.edu

Edgar Berdahl

CCRMA
Stanford University
Stanford, CA 94305 USA
eberdahl@ccrma@stanford.edu

Abstract

Good controllers for performance of computer music, can be “responsive but also assertive”. They seem to require high resolution, high-bandwidth, and (usually non-linear) feedback from force-in to force-out.

Keywords

Haptics, Music-control, Micro-controllers.

ACM Classification Keywords

H5.2 User-Interfaces [Haptic I/O], H5.5 Sound and Music Computing.

Introduction

Systems for force-interaction (haptics), are more capable now with low-cost actuators and sensors, fast micro-controllers and signal-processors, and open-source software tools.

In teaching HCI for music at Stanford, we have built a series of simple force-feedback devices and programmed them with a variety of micro-controllers, personal-computers and most recently a single-board computer (BeagleBoard).

They can be what we might call “assertive”.

Copyright is held by the author/owner(s).
TEI'11, Work-in-Progress Workshop
Jan 23, 2011, Madeira, Portugal.

Key features

Some common features seem to be essential.

- In contrast to vibrotactile displays as on mobile phones and computer games, they can produce a constant force (d-c) which sometimes requires being anchored to the environment.
- They have sensors (position and force) which can be used to create close-loop, marginally stable systems.
- Sample-rates must be high and latencies low; often a local micro-controller allows higher performance.

CCRM's "assertive" devices.

- Haptic Drum (Berdahl, 2009)
- The PLANK (Verplank, 2001)
- Cellomobo, Collin Oldham (2008)
- Force-Stick (Verplank, 2005)
- Fader-Synth (Georg, 2010)

Haptic Drum.

When you hit Ed Berdahl's haptic drum[2] with a stick, it kicks back using a speaker coil (woofer). Depending on which target you hit with the stick, the drum will make a different sound. By varying the way you hold the stick, the Haptic Drum enables you to play drum rolls that would otherwise be difficult or impossible. For instance, drum rolls can be played at superhuman speeds of up to 70Hz.



Figure 1. Berdahl's Haptic Drum.

The PLANK

"The PLANK" [1] is made from an old hard-disk drive by removing the disks and using the head-positioning voice-coil actuator to move a cylindrical surface. A force-sensitive resistor senses the force of the user's fingers on the surface. With a simple program on the AVR controller, if you push "into" the surface, it "sides down" a virtual profile - e.g. the envelope of a wave or sample.

In a recent workshop [9] with Bill Verplank and David Zicarelli, Roger Reynolds used the PLANK with Hans Tutschku's granular synthesis (running in MAX/MSP). As Roger bounced the PLANK around the envelope of the sample, he remarked that "it's a situation in which the instrument is not only responsive, it's also assertive".

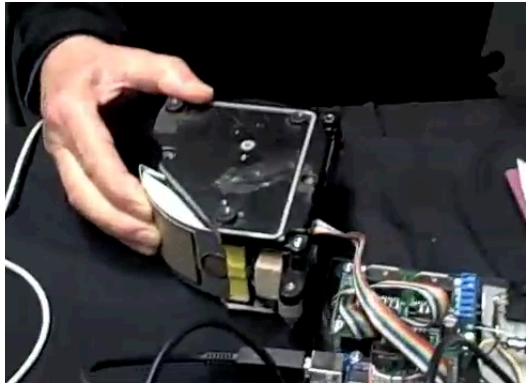

Figure 2. Verplank's PLANK.

Cellomobo

In Collin Oldham's Cellomobo [8], the "bow" is a wooden dowel, the "string" is the blade of a painter's palette knife with a piezo pickup attached. The signal goes via Arduino to Pd where it is delayed by an amount determined by his left hand on a "string" sensor acting as a linear potentiometer. Finally, the delayed signal is amplified a shaker vibrates the palette knife orthogonal to the motion of the bow, making it stick and slip.

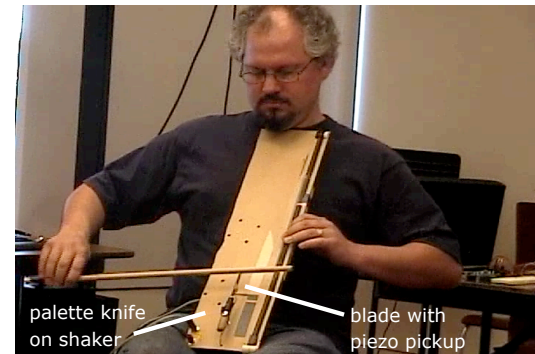

Figure 3. Collin Oldham playing his Cellomobo.

Force Stick on the BeagleBoard

Edgar Berdahl has programmed a library called HSP (Haptic Signal Processing) for MAX/MSP and for Pd which does physical modeling [6]. Under Linux, it can run on the BeagleBoard. Adding the Arduino, he calls this combination "Satellite CCRMA".

Verplank's Force-Stick [3] sends sensor signals to the BeagleBoard via the Arduino Nano. The dynamic behavior is computed at audio-rates in Pd on the BeagleBoard and a force command is sent via the Arduino's PWM to the H-bridge amplifier on the Force-Stick.

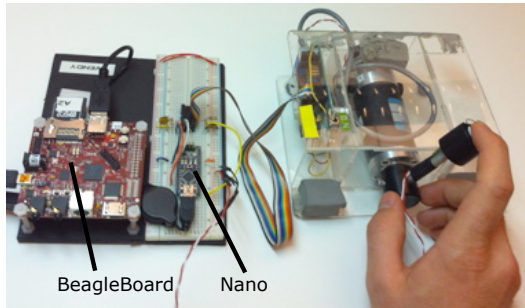

Figure 4. BeagleBoard, Arduino Nano, Force-Stick..

FM Fader Synth

At Stanford's CCRMA, in Music 250A [5] Francesco Georg programmed a virtual mass-spring system in Pd running on a BeagleBoard using Berdahl's HSP. With the fader, he "throws" the mass as it "bounces" over a landscape of FM synthesis parameters.

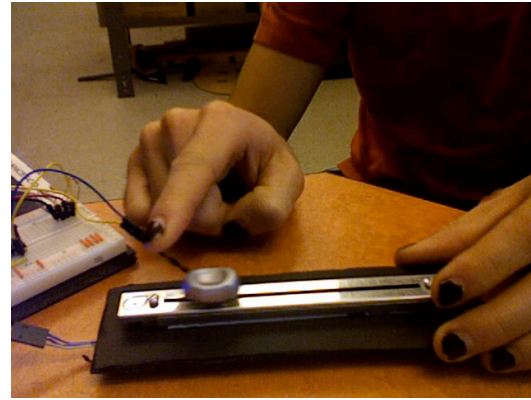

Figure 5. Francesco Georg "throwing" a motorized fader.

Conclusions and future work

This quality of being “assertive” seems to capture the excitement of this collection of devices. What they share technically is the question. This is truly work-in-progress.

Acknowledgments

Thanks to Chris Chafe, Max Mathews, Michael Gurevich, Wendy Ju, Ed Berdahl and the students of “Physical Interaction Design for Music”.

Citations

- [1] Verplank, B., Gurevich, M. and Mathews, M. The PLANK: designing a simple haptic controller. In *NIME '02: Proceedings of the 2002 conference on New Interfaces for Musical Expression*, ACM Press (2002).
- [2] Berdahl, E. Haptic Drum <<https://ccrma.stanford.edu/~eberdahl/Projects/HapticDrum/index.html>>
- [3] Verplank, W. Haptic music exercises. *NIME '05: Proceedings of the 2005 conference on New interfaces for Musical Expression*. ACM Press (2005).
- [4] Berdahl, E. *Applications of Feedback Control to Musical Instrument Design*, PhD Thesis, Stanford University (CCRMA), Stanford, CA, 2009.
- [5] Berdahl, E., Ju, W, Physical Interaction Design for Music. <https://ccrma.stanford.edu/wiki/250a_Haptics_Lab_Force-stick>
- [6] Berdahl, E., Kontogeorgakopoulos, A., and Overholt, D. HSP v2: Haptic Signal Processing with Extensions for Physical Modeling, *HAI'D'10*, <http://media.aau.dk/haid10/HAI'Dposters.pdf>.
- [7] Gabriel, R., Sandsjo, J., Shahrokni, A, Fjeld, M. BounceSlider: Actuated Sliders for Music Performance and Composition, *Proceedings of the Second International Conference on Tangible and Embedded Interaction (TEI'08)*.
- [8] Oldham, C. Cello-mobo. <<http://homepage.mac.com/coldham/klang/cello-mobo.html>>
- [9] Incubator 2010: Beyond the instrument metaphor: new paradigms for interactive media. Arizona State University, February 19-21, 2010. <<http://ame.asu.edu/events/incubator/>>..

Pleistocene interactive painting

Koji Pereira

Federal University of Minas Gerais (UFMG)
Belo Horizonte, Brazil
koji@interactionsource.com

Vivian Teixeira Fraiha

PUC Minas Museum of Natural Sciences
Av. Dom José Gaspar, 290
Belo Horizonte, Brazil
vivianteixeira@pucminas.br

Fabiane Niemeyer Esposel de Mello

PUC Minas Museum of Natural Sciences
Av. Dom José Gaspar, 290
Belo Horizonte, Brazil
contatofabiane@gmail.com

Thássia Fátima Lara

PUC Minas Museum of Natural Sciences
Av. Dom José Gaspar, 290
Belo Horizonte, Brazil
contatothassia@gmail.com

André Veloso Junqueira

Interaction Source
Belo Horizonte, Brazil
andre@interactionsource.com

Marcos Paulo Machado

Pontifical Catholic University of Minas Gerais, Institute of Continued Education (IEC PUC Minas)
Belo Horizonte, Brazil
marcos@interactionsource.com

Abstract

The PUC Minas Museum of Natural Sciences, located in Belo Horizonte, Minas Gerais, Brazil, was founded by the Pontifical Catholic University of Minas Gerais, in 1983. It houses one of the most important fossil collections of South America, with over 70 thousand pieces and receives more than 50 thousand visitors per year. This work was guided by the concept of museums as places for non-formal education and, within this perspective, by the possibility of innovation and use of the tangible interaction to increase the participation and immersion of visitors. The intention was not to turn the museum into a technological or digital only museum, but to increment the technology to the analog experience. To achieve this goal was used augmented reality overlapping digital images on a Pleistocene painting and arduino micro-controllers to turn on or off some fossils showcases. This paper is a collection of some findings, through design process.

Keywords

Natural sciences museum, exhibition design, tangible interaction, augmented reality.

ACM Classification Keywords

H5.1. Information interfaces and presentation (e.g., HCI): Multimedia Information Systems, Artificial, augmented, and virtual realities.

General Terms

Design, reports.

Copyright is held by the author/owner(s).

TEI'11, Work-in-Progress Workshop
Jan 23, 2011, Madeira, Portugal.

Introduction

The PUC Minas Museum of Natural Sciences, founded on July, 1983, is an interdisciplinary space of the Pontifical Catholic University of Minas Gerais. It hosts one of the biggest fossil collections on South America, besides a scientific flora and fauna specimen collection. This dynamic institution conjugates research, education, culture and entertainment. The Museum is affiliate to International Council of Museums (ICOM).

The PUC Minas Museum has an important paleontological collection, with about 70 thousands pieces, highlighting mammals fauna from the Pleistocene, period between 1,8 million and 11 thousand of years ago, including animals like the giant ground sloth, the giant armadillo, the sabre-tooth tiger, the toxodon, the mastodon, the Protopithecus monkey, among others, including the description of new species. All this helps to understand the evolutionary process of some groups.

“Hands on” interactions

Since the end of the 20th century, the debate about interaction on museums became popular [8]. To update the PUC Minas Museum and at the same time make the Museum more attractive and interactive, this project was funded by Foundation for Research Support of Minas Gerais.

The initial proposal from PUC Minas Museum was to make the “Big Extinction: 11 thousand years” exhibition more interactive and engaging through an audio-visual spectacle. The focus of this action was a painting of 12,8m X 3,9m that pictures the environment and the animals that dwelt Brazil in the Pleistocene (fig. 1).



figure 1. Pleistocene painting. Photo by Marcelo R. Viana.

The first idea was a linear proposal, without any “hands on” interaction. In the first meeting was discussed the possibility to move to something interactive, allowing visitors to act into the painting. The concern of losing the focus in the scientific subject was related by the Museum coordinators. So, the challenge was create a non-distractive interaction, but something that could increase the immersion into the subject, allowing visitors to learn and engage into the interface.

To understand the behavior of visitors and how the museum staff present guided tours, two designers had observed visitors and museum staff in a whole day. The main finding pointed that experience of museum visiting is basically social. The visitors usually talk with which other about the objects and there's a general curiosity, so there's always a lot of questions directed to museum staff.

Contextual inquiry is a field data-gathering technique that studies a few carefully selected individuals in depth to arrive at a fuller understanding of the work practice across all customers. Through inquiry and interpretation, it reveals commonalities across a system's customer base. [7]

A simultaneous multiple user interaction was something wanted, because the experience of visiting a museum is a social event, not an individual activity. The

development should also respect the characteristics of a natural sciences museum, the importance of pieces, and not to turn it into only a technological museum.

Designing interactivity

After a couple of meetings, the ideas come to reality in some 3D sketches, interactive flows and storyboards.

The tack that we are going to pursue is that sketching in interaction design can be thought of as analogous to traditional sketching. Since they need to be able to capture the essence of design concepts around transitions, dynamics, feel, phrasing, and all the other unique attributes of interactive systems, sketches of interaction must necessarily be distinct from the types of sketches that we have looked at thus far. [2]

The main solution was the use of augmented reality to keep the painting intact and at the same time add interactivity and motion to it. To get this effect the solution chosen was an interactive surface over the painting, using an infrared laser, captured by a camera connected to a computer running Open Frameworks with OpenCV library. As a pointer, the infrared laser was chosen because a visible light laser could affect the visibility of the UI, creating an undesirable visual noise. Another possibility was a "body only" interface. With one webcam it is possible to capture gestures without any accessories, as the example of Microsoft Kinect [9], but this could mean a much more expansive development and a non-accurate and individual experience.

The infrared laser was a difficult item to bought. It was found only on EBay[4], with a Chinese seller.

This seemed to be a clearer solution to make the painting interactive. Although the linear narrative was kept, the Museum staff could start this narrative whenever they want, after or before start the whole interaction panel.

To extend the painting interactivity, an interactive floor was planned to as an extension of the painting on the bottom of the panel. Interactive Floor is a very well documented kind of installation and could be find at NUI Group website [10].



figure 2. 3D prototype scheme.

To keep the real environment integrated with the digital interaction, we chose to make the showcases interactive too. So while users point to an animal, in the painting, with the infrared laser, the relative showcase with fossils samples is enlighten.

Development

To start the development, a comprehensive study was done. Starting with the Main Projection System, it was needed a way to acquire the pointer position and interpret it. "Community Core Vision, CCV for short, is

an open source/cross-platform solution for computer vision and machine sensing. It takes a video input stream and outputs tracking data and events that are used in building multi-touch applications.” [3] Although the CCV is focused on multi-touch tables, it is possible to use the ability to find blobs to other purposes. There is no software limitation for use of blobs, but to avoid a lot of mixed interactions simultaneously, it was limited to 3 blobs at the same time. To create the UI at the main projection, Adobe Flash Toolkit was used to generate the info windows, and the audio layer was generated in Pure Data [16]. For the linear narrative, a framework based on IanniX [5], that calls animations and sounds, and could be manipulated as a video edition software in development stage. All animation elements are independent and animated using Adobe Flash [1] technology.

The OpenFrameworks [11] toolkit was used to create the interactive floor, together with OpenCV [13], to capture user interaction by an Infrared laser pointer, with a camera.

To communicate all these platforms, a structure of OSC [14] messages was developed. All items are communicating through this structure (fig. 3).

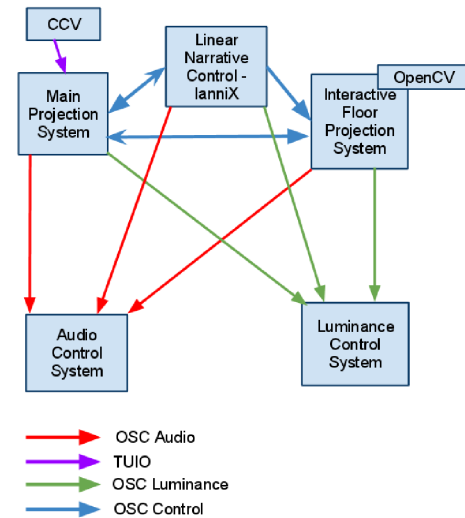

figure 3. Software structure.

Hardware solution

The hardware structure is determinant to this project. With a fixed budget to buy all equipment, design and develop, all savings were welcome. The Main Projection System should cover all painting surface, 12,8m X 3,9m, with a good resolution. It could have been used an outdoor large projector, but due the high price, a second solution was to use two small projectors. As the projected surface has already images, sometimes too dark to see, a high luminance projector was needed. Another requisite was the final screen size 12,8m X 3,9m, to find the appropriate projector the reference of

Projector Central website [12] was essential, a lot of comparisons was made, but the only official reseller available in Brazil was Sanyo. The model Sanyo XU-106, fits the needs as a 4,500 ANSI lumens projector, and as calculated in Projector Central the throw was enough to create screen with 2 projectors to fit the 12,8m X 3,9m painting.

To avoid a lot of long VGA and Firewire cables, was chosen to install all equipments on the ceiling, using support beams to fix computers, projectors and cameras. However a wireless networks will be installed to allow remote maintenance, small adjusts and for calibration an IR remote control will be used. The main issue with IR remote controls is the lack of a turn on button. To fix this, an IR circuit was bough on internet [6].

Next steps

For conclusion of PUC Minas Museum installation, some things are pending. The time planned initially was not enough to conclusion of all tasks. One important point not finished is the adjust of electrical installation, because it is necessary to change the electrical structure to allow the luminance control with Arduino micro-controllers [15]. This structure is essential to finish the installation.

The configuration software still a work-in-progress, the idea is to develop a full functional setup workspace to avoid the necessity of technical maintenance.

Before the final installation, a test week is planned, when the adjusts will be made until the appropriate final version be available to visitors.

Citations

- [1] Adobe Flash <http://www.adobe.com>
- [2] Buxton, B. Sketching User Experience. San Francisco, CA. Elsevier, 2007.
- [3] Community Core Vision <http://ccv.nuigroup.com/>
- [4] Ebay <http://www.ebay.com>
- [5] Iannix <http://sourceforge.net/projects/iannix/>
- [6] IR Circuit <http://www.simerec.com/PCS-2.html>
- [7] Kuniavsky, M. Observing the User Experience - A Practitioner's Guide to User Research. San Francisco, CA. Elsevier, 2003.
- [8] Loureiro, M.L.N.M.; Silva, D.F. A Exposição como "obra aberta": breves reflexões sobre interatividade. *X Reunión de la Red de Popularización de la Ciencia y la Tecnología en América Latina y el Caribe (RED POP - UNESCO) y IV Taller "Ciencia, Comunicación y Sociedad"*
San José, Costa Rica, 9 al 11 de mayo, 2007
<http://www.cientec.or.cr/pop/2007/BR-MariaLuciaLoureiro.pdf>
- [9] Microsoft Kinect. <http://store.microsoft.com/content.aspx?cntId=8807>
- [10] Nuigroup <http://nuigroup.com/go/>
- [11] Openframeworks <http://www.openframeworks.cc/>
- [12] Projector Central <http://www.projectorcentral.com/>
- [13] OpenCV <http://sourceforge.net/projects/opencv/>
- [14] OSC protocol <http://opensoundcontrol.org/>
- [15] Arduino <http://www.arduino.cc/>
- [16] Pure Data <http://puredata.info/>

Delicate Interpretation, Illusion and Feedforward: Three Key Concepts toward Designing Multimodal Interaction

Kumiyo Nakakoji

Software Research Associates, Inc.
2-32-8 Minami-Ikebukuro,
Toshima, Tokyo, 171-8513, Japan
kumiyo@sra.co.jp

Yasuhiro Yamamoto

Precision and Intelligence Laboratory
Tokyo Institute of Technology
4259 Nagatsuda, Midori,
Yokohama, 226-8503, Japan
yxy@acm.org

Nobuto Matsubara

Software Research Associates, Inc.
2-32-8 Minami-Ikebukuro,
Toshima, Tokyo, 171-8513, Japan
matubara@sra.co.jp

Copyright is held by the author/owner(s).
TEI'11, Work-in-Progress Workshop
Jan 23, 2011, Madeira, Portugal.

Abstract

This paper argues that *delicate interpretation*, *illusion*, and *feedforward* as three key concepts in designing future multimodal interaction. The human brain has its peculiar nature of integrating information coming through different sensory channels to construct a consistent model of the world. The notion of direct manipulation and feedback based on the truthful reflection of the physical world may no longer be the guiding framework for designing tangible, embedded, and embodied interaction. HCI designers (as well as brain scientists) have very limited understanding on how the brain models the external world by using multimodal information. *TCieX* (Touch-Centric interaction embodiment eXploratorium) has been built to help us experience and understand the combinations of different modes of interaction, and explore the three key concepts in designing multimodal interaction.

Keywords

Interaction design, multimodal user interface, pseudo haptics, delicate interpretation, illusion, feedforward

ACM Classification Keywords

H.5.2. Information interfaces and presentation (e.g., HCI): User Interfaces.

General Terms

Design, Theory

Introduction

Our approach in designing embodied interaction is based on the view that looks at multimodal interaction as a way that one's brain interacts with the external world through his or her different sensory channels.

The human brain has its peculiar way of integrating information given through different sensors to construct a consistent model of the world. Some sensory systems dominate other sensory systems, and if information given through multiple sensors is inconsistent, the information given through a dominant sensory system overwrites the information given through recessive sensory systems. This makes the person sense what is not physically present through the recessive sensors, which we may call an illusion. Pseudo haptics is a typical example [2].

Pseudo-haptics occurs when visual properties and tactile properties captured through the sensory channels exhibit an inconsistency, or a conflict, in terms of the model of the world a person expects to perceive. Visual properties are dominant over tactile properties, and therefore, the person perceives tactile properties different from the actual physical properties so that the perceived visual and tactile properties produce a coherent view of the world. Pseudo-haptics on texture has been widely applied by changing the size and the speed of the mouse cursor displayed on a screen in

terms of the user's mouse movement [1]. Watanabe et al. [5] has exhibited the force of the wind, harsh surface, and wavy tin-roof, by changing the visual size of the mouse cursor.

We think that designing multimodal interaction needs to take into account such nature of the human brain in terms of how it models the external world by using information coming through different sensory channels. This might complicate how we design multimodal interaction, but more interestingly it would open up a vast area of opportunities to realize new types of experience for users.

In this regard, we think three new notions need to be taken into account in designing multimodal interaction: *delicate interpretation*, *illusion*, and *feedforward*. Direct manipulation and feedback have been two important notions in designing interaction when using the traditional keyboard and mouse. The two notions essentially deal with the issue of how to accurately communicate the state of the world with a human user through visual representations. Auditory and tactile representations may be combined to reinforce the "accurate" interpretation. When it comes to be concerned with how a brain models the world based on the input data from different sensory channels, the goal of truthfully reflecting the physical reality becomes questionable. The field of brain science is just about to start exploring the area and so far HCI designers have very limited understanding on how to effectively use multiple sensory channels. We need environments where we can build and experience different combinations of multimodality.

In what follows, we first discuss what we mean by *delicate interpretation*, *illusion*, and *feedforward*. We then describe a tool we have been developing to help us experience and understand the combinations of different modes of interaction. The tool, TCieX (Touch-Centric interaction embodiment eXploratorium), currently focuses on the visual dominance of sensory systems over haptics.

Delicate Interpretation, Illusion, Feedforward

This section describes the three key notions that we think becoming essential in designing multimodal interactions.

Delicate Interpretation:

By delicate interpretation, we mean a “liberal” interpretation of the data produced by human behavior.

One of the goals of sensor technologies used in multimodal user interfaces has been how to accurately capture physical action of a user. The physically sensed data, however, may not reflect what the user really meant, intended, or is aware of producing. A simple example is saccadic eye movement. What the user meant is to stare still, but the eyes move at the physiological level.

Delicate interpretation, or liberal, mindful interpretation, is necessary to generate a meaningful feedback to the user when using data collected by external sensors. Touch-based user interfaces signify the relevance of the point to interaction design. Human body movement has certain characteristics, and fingers are no exceptions. When a person thinks he or she is drawing a straight line with an index finger on a touch-

sensitive display, the coordinates collected through a series of touched area may not constitute a straight line but a number of crooked segments, not because of the inaccuracy of the touch sensors, but because of the characteristics of the finger movement. Visually displaying the segments in accordance with the coordinates might be the accurate reflection of the user’s physical activity, but it would not be what the user really meant to do.

Illusion:

Multi-modal environments have tried to enforce more immersive, more realistic feedback, such as through organic user interfaces, where input equals output [5]. Illusions have been regarded as something to be taken care of in interaction design. Illusion may cause a wrong interpretation of the information presented to a user, and therefore, something not desirable.

The use of illusion, such as the pseudo-haptic feedback, however, makes us consider how a user perceives the world through multiple sensory channels. The physical world is not necessarily the ideal situation for a user. We may need to alternate information on some of the channels so that the user would perceive the world more effectively. We think that properly situated illusion should be more explored and used in interaction design. The notion of direct manipulation in interaction design, then, may need to be re-contextualized.

Feedforward:

People interact with the external world based on the pre-understanding of the world. The human brain plans how much force to put to on the muscles of the forearm before holding a book so that the arm neither tosses up the book nor drops the book. This planning is only

possible by looking at the book, with the pre-experienced knowledge of the relation between the look of a book and its weight.

Interaction design has focused on how to present feedback for a user's action so that the user understands how the user's action has been interpreted by the system, and what the system has been doing in what context. Based on this feedback, the user plans for the next action.

The same presentation of the information might be viewed as feedforward information for the user's subsequent action. Pseudo haptics occur only when the user has built a model between the hand movement and the movement of the visual object. Such setting is necessary for the subsequent weight illusion to take place.

The notion of feedforward becomes essential in designing multimodal user interaction for guiding, persuading, or eluding a user's certain actions.

The TCieX System

TCieX (Touch-Centric interaction embodiment eXploratorium) is a collection of simple interaction test suites that help us experience different combinations of multimodal interactions. It currently focuses on visual and haptic sensory systems.

Figure 1 shows one of the interaction test suites implemented on TCieX, "*two panes*," which currently runs on Apple iPad.

The basic interaction *two panes* provides in the "Trial" mode is that the user touches the lower pane with a finger tip and moves the finger, a ball-like object in the upper pane moves accordingly.

two panes allows the user to create different mapping between the movement of the finger in the lower pane and that of the object in the upper pane by using the right column in the "Setting" mode. A user then actually experiences the interaction with the setting in the "Trial" mode.

For instance, suppose a user moves the fingertip from left to right with the constant speed in the lower pane. The object in the upper pane starts moving faster when the object enters the area displayed with the reddish contour. The degree of redness represents the scale of speeding-up. Selecting one of the four radio buttons (flat, Gaussian-curve, bell-curve, and triangular shapes) determines how the acceleration is applied. Reversely, when the object enters the bluish contour area, the object starts slowing down. Changing such mapping (what [2] calls the Control/Display ratio) make us feel a hole (by speeding up) and a bump (by slowing down) on the surface in the upper pane (i.e., pseudo-haptics).

With the Setting mode, one may change where to put such colored contour areas with what size and where the apex is. When the user touches the upper pane and holds the fingertip still, a color-gradient contour appears. It can either be reddish or bluish, depending on the "+" or "-" option the user selects in the right column of the pane.

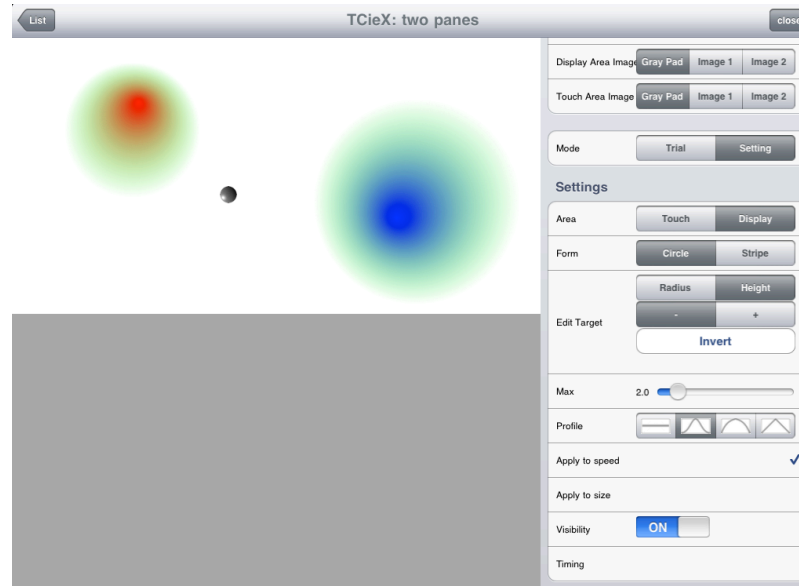

Figure 1. *two panes*, one of the interaction test suites of TCieX

One may turn off the visual display of the contour, by turning the visibility off. We may also change the visual size of the object in addition to changing the speed of the object movement. Then, the movement of the object remains the same, but with dynamically changing the visual display. We may feel the interaction with the object a little differently as reported in [1].

We may even apply the contour drawing in the lower pane. When a bluish contour is created in the lower pane, mechanically it is not the movement of the object

that starts slowing down, but it is the interpretation of the movement of the figure tip's movement as slowing down.

Discussion

TCieX is still at an early stage. It currently has two dozens of test suites, or exploratorium, to explore different modes of interactivity such as *two panes* described in the previous section.

What we want to demonstrate by building TCieX is a way to explore how different visual and haptic modes affect how we experience the interaction. By allowing a user of TCieX to explore different modes with different parameters varying the visual and haptic sensations, we are hoping to help the user to better understand how to combine visual and haptic properties for building his or her own application system.

One application area we have been thinking to apply such multimodal interaction is to communicate weight [3]. For instance, we may apply the technique as a way to give a feedback to a doctor engaging in remote operation. The force put on the knife of a remote operation robot can be communicated with the doctor through visual and auditory feedback. As another example, one may communicate how a product under design weighs with remote team members in a distributed design meeting. As a third example, the weight should not necessarily be that of a physical object, but could be associated with a conceptual property. Programming component that has significant impact on other components could be assigned heavy weight so that a programmer may perceive the weight of importance of the component when editing it.

In designing a system with multimodal interaction, the visual, audio, haptic, olfactory, and even gustatory information displays become much more complex than the traditional keyboard, mouse and LCD-based interaction because we do not have much understanding on how the brain interprets the information coming through multiple sensory channels. As interaction designers, our job is not to understand

the mechanics of the brain, but to understand how the brain interprets and models the world so that we can take an advantage of the nature. It is not about brain interface in the narrow sense. Multimodal interaction systems use a person's sensory systems as instruments for the brain. Such concerns would open up the wide area of research in human-computer interaction, especially in tangible, embedded, and embodied interaction.

Acknowledgements

This work was supported by JST, CREST.

References

- [1] Lecuyer, A., Burkhardt, J.M., Etienne, L. Feeling Bumps and Holes Without a Haptic Interface, The Perception of Pseudo-Haptic Textures, Proceedings of CHI2004, Vienna, Austria, (2004) pp.239-246.
- [2] Lecuyer, A. Simulating Haptic Feedback Using Vision: A Survey of Research and Applications of Pseudo-Haptic Feedback, Presence: Teleoperators and Virtual Environments, (2009) Vol.18, No.1, pp.39-53, MIT Press.
- [3] Nakakoji, K., Yamamoto, Y., Koike, Y., Toward Principles for Visual Interaction Design for Communicating Weight by using Pseudo-Haptic Feedback, Proceedings of Create 10 Conference, Edinburgh, UK, (2010) pp.68-73.
- [4] Vertegaal, R., Poupyrev, I. Organic User Interfaces: Introduction to Special Issue, Communications of the ACM 51(6), (2008) pp.26-30.
- [5] Watanabe, K., Yasumura, M., Realizable user interface: The information realization by using cursor, Proceedings of Human Interface Symposium, (2003) pp. 541-544, (in Japanese).

Developing a Tangible Interface for Storytelling

Cristina Sylla

University of Minho
engageLab/CIED
Guimarães/Braga-Portugal
sylla@engagelab.org

Pedro Branco

University of Minho
Dep. of Information Systems
Guimarães-Portugal
pbranco@dsi.uminho.pt

Clara Coutinho

University of Minho
Institute of Education
Braga-Portugal
ccoutinho@ie.uminho.pt

Copyright is held by the author/owner(s).

TEI'11, Work-in-Progress Workshop
Jan 23, 2011, Madeira, Portugal.

Abstract

This paper describes a first study of a paper based interface, consisting of a large format book and a set of picture cards that children can use to create stories. The handling of the picture cards has shown to be highly motivating and engaging, helping children to build a storyline creating logical relations among different characters and objects. The interface has shown to be an experimental space where children can play with the language and simultaneously reflect over it, in a collaborative process. We present the data collected with a group of five years old preschoolers and report our findings regarding the interaction design, as well as a reflection over future work.

Keywords

Children, Tangible Interfaces, Paper based Interfaces Storytelling, Interaction Design.

ACM Classification Keywords

H5.m. Information interfaces and presentation (e.g., HCI): Miscellaneous.

General Terms

Human factors

Introduction

This work is part of a broader project that aims to develop a kit of tangible interfaces for preschool education to provide children with a set of tools to build their own learning materials, promoting exploration, experimentation and creative production.

Stories have always been intricately linked to the world of childhood, children simply love to hear and tell stories, and it is precisely through storytelling and fantasy role play that they explore and learn to know the world around them [4]. Thus inventing, creating and telling stories is fundamental to the development of the child both as an individual as well as a social person [11,5]. Through an experimental and exploratory process the children experience how others behave and feel, trying out different roles, identifying positive and negative aspects, while learning to express themselves and to communicate with others. The competence of being able to express oneself and to communicate with others implies the gradual acquisition of the discourse rules [1] and that goes together with the need for experimental spaces where children can play and experiment with the language [1,2]. Building sentences, redoing sentences, changing the elements, playing with the word order, learning new vocabulary, and redoing everything again if not satisfied. In recent years there has been a growing awareness in the development of technology that supports child-driven play and creativity and an interest in developing solutions that promote free expression, creativity and fantasy play engaging children as story authors [2,5,6]

The paper based interface presented here is intended as a tangible platform where children can create their own stories by placing picture cards on a book page,

rearranging them until creating meaningful sequences and stories. As the cards give written and oral feedback after being placed on the book, they help children to reflect on their narratives. The tangibility of the interface supports children's creative expression making it easy for young children to interact with the content [21], transforming the creation of a story in a multitude of stimuli that range from: sensory, visual and auditory. According to Gardner: "Words, pictures, gestures and numbers are among the multifarious vehicles marshaled in service of coming to know the world symbolically, as well as through direct physical actions upon it and sensory discriminations of it" [10]. Body motion and sensory perception such as touch, sight and hearing are crucial to children's development [11,14] facilitating learning and content retention [21]. Therefore, educational environments should support those physical activities.

An interface for Storytelling

The interface presented here introduces a book for children to create their own stories. The current prototype consists of a set of picture cards and a large format book. The pages have rectangular marks on it, that have the same diameter as the picture cards, so that each card fits exactly over it. They are used to define and indicate where the cards have to be placed.

Design and Implementation

Telling and reading stories are part of the daily activities carried at preschool; very often someone reads a story showing the children from time to time the drawings on the book pages. Sometimes the children are asked to make drawings of it, or puppets out of different materials and then retell the story using the materials they have created. In

order to develop an interface that would meet children's needs and to incorporate their ideas and feedback into the design of the interface [8,9] we were lucky to work with a group of 26 children of five years of age. During one of the first sessions with the children we read a story and asked them to draw the characters. Each child chose a character and drew it on a paper card. The characters were divided through the children so that each card had only one character represented on it. A large format book with blank pages was placed on the floor in the middle of the room, the children sat around and we asked them to tell the story using their picture cards. The children placed the cards on the book and each one told her/his part. They did not seem very engaged in telling the story; instead the activity resembled more a memory exercise, living no space for children's creativity. That led us to rethink the design of an interface that would be able to engage children in creating their own stories and we finally came to the idea of developing a book not to read but to invent stories.

How does it work?

The book functions as the work area, where the picture cards are placed. The picture cards are based on tag technology triggering audio; each card is identifiable by the system and can be placed everywhere on the book marks.

Every picture card has only one element represent on it. At the moment the cards comprise only a reduced number of elements, such as: animals, toys, food, actions, places, weather and times of the day. In the future more series of cards will be developed, so that the children can have a wider range of elements to create more complex stories. The children can pick the cards, choosing the elements they like/need to create a

story and place them on the book page, each card over a mark. When a card is placed on the mark it gives audio feedback according to the element drawn on it. For instance when the dog is placed it triggers the sound "dog". As an example, imagine a story about a cat that goes to the forest, plays with a ball and when it begins to rain goes home and drinks a bowl of milk. So the child to create the story above has to place the following sequence of picture cards: cat → go forest → ball → rain → go home → bowl of milk. At the time s/he is placing the cards s/he hears the story: "The cat, goes to the forest, plays with the ball, it rains, goes home, drinks a bowl of milk." The children can rearrange the story by changing the sequence of the cards, by adding new ones or by removing some of the ones they have used.

Testing the Interface

Designing the interface was an attempt to engage children in creating stories, to encourage their imagination, to make them think, to learn building logical sequences as well as to develop new vocabulary. The current version of the prototype was tested with the same preschool children, but this time we worked with a small group of twelve children divided in two groups of six.

The prototype was placed on a table and six children at a time stood around it. Initially we planned to ask three out of the six children to look through the picture cards, choose the ones they like, place them on the marks so that they could create and hear a story. Unexpectedly all the six children tried to grasp the cards, being so deeply involved from the beginning, that it was impossible to build two groups of three, instead the six children worked together. They began immediately to place the cards on the book, in a very dynamic process,

dealing with each other, which card would fit better the narrative, trying to create a story (fig.1). Both groups of six children behaved similarly.



Figure 1: Children building a story

Does it make sense?

At the beginning the children chose the pictures they liked most and positioned each card over a mark, but after hearing the completed sequence they felt the need to make some changes, since some cards did not match neither with the following nor with the previous ones. For instance one of the groups chose the following sequence: it is sunny → goes home → goes to the playground → plays with the ball → hides the bone → plays with the yarn ball. The teacher, who was in the background and did not know the interface in advance, decided to go between and talked with the children about the storyline, leading them to the conclusion that they had first to define a character before choosing an action [1]. Finally the children rearranged the storyline and created a story about three animals, with the following cards: the dog → hides the bone → it is sunny → plays with the ball → the mice → eats the cheese, the cat → drinks a bowl of milk → it rains → goes home → plays with the yarn ball → it is night. The fact that the content is attached to the cards led the children to think of how a story is built as well as about logical sequences.

Behind the Interface

In addition to work out how a narrative is built, when the children had finished the story, the teacher had the idea to ask the children to tell the story themselves following the sequence of the picture cards. This way she was able of expanding the use of the interface, as the words/sentences triggered by the cards are rather simple. The children can thus retell a more elaborate story and if they want they can just find another meaning for the pictures, so that different levels of the story can be created. The storyline works as a support and guideline. At the end, when the children are happy with their stories they can press a button to send the story to their class blog.

Related work

In the last decade there has been a growing interest in developing tools for children that allow them to create stories in a more active and creative way promoting story authoring and collaboration among peers. Many researchers have shown that collaboration significantly raises the level of engagement and activity by children and at the same time has the potential to have beneficial effects on learning [3,12,20,22]. Additionally the tangible interaction frees children from mouse and keyboard creating a more natural interaction [5,13]. Some examples of such interfaces are: Kid story [3], 1001 Stories [7], StoryMat [5], TellTale [2], Pogo [6], Jaberstamp [17], SPRITE [19] or Singing Fingers [18].

Discussion

Following this line of development the prototype presented here pretends to be an experimental space, where children can explore the language, using their body and senses. The major contributions of this interface are the simplicity of the set up, which would

make it easy to implement at preschool or at school, as well as being a tangible space, made out of materials traditionally used at preschool, for playful exploration bringing together visual, auditory and sensory stimuli. A space where children can find out and learn about logical relations and sequences, enhancing their creativity and ability to create stories by working together and collaborating with each other. Instead of telling children a story and work that story with them using drawings or puppets, this interface, in turn, aims to promote children's potential in imagining, creating and sharing their own stories. At the same time it can be used by the teachers to propose a series of educational activities. The picture cards can work as an input for the creation of the stories helping children to generate ideas. It was noticeable in children's first attempt to build a story that at this age it is still not easy to build logical relations; since the cards give auditory feedback the system might foster a better understanding of a storyline, working at the same time as an experimental space to reflect about the language helping children to build logical relations and to develop their literacy. As we found out such a challenge has revealed very motivating for the children, who engaged from the beginning in creating a story. The recorded stories, which can be uploaded to children's class blog allow seeing children's progression over the time and at the same time allow for sharing with family and friends.

Conclusions and Future work

We have reported on the design and first testing of a paper based interface for children to create stories. Our observations showed that the physical handling of the pictures was very motivating and engaged children from the beginning in creating their own stories. The interface has shown to promote collaborative work and

to function as an experimental space where children can play with the language and at the same time reflect over it. In future work we plan to develop different sets of cards that focus on different skills. Further we plan to embed light and sensors on the cards so that it is possible to extend the kind of exercises and activities supported by the interface. We also think of giving the children the possibility to draw and record their own cards. Further we hope to contribute with our research to the discussion on the cognitive benefits related to the physical manipulation of materials [15,16].

References

- [1] Ackermann, E. Language Games, Digital Writing, Emerging Literacies: Enhancing kids' natural gifts as narrators and notators. *Information and Communication Technologies in Education. Proc. 3rd Hellenic Conference with international participation 2002*. 31 – 38.
- [2] Ananny, M. Telling Tales: A new toy for encouraging written literacy through oral storytelling. *Society for Research in Child Development*, Minneapolis, MN, 2001.
- [3] Benford S, Bederson B, Akesson K, Bayon V, Druin A, Hansson P, Hourcade JP, Ingram R, Neale H, O'Malley C, Simsarian KT, Stanton D, Sundblad Y, Taxen G. Designing storytelling technologies to encourage collaboration between young children. In *Proc. CHI 2000*, ACM Press (2000), 556 - 563.
- [4] Bruner JS. *The culture of education*. Harvard University Press, Cambridge, MA, USA 1996.

- [5] Cassell, J., and Ryokai, K. Making Space for Voice: Technologies to Support Children's Fantasy and Storytelling. *Personal Ubiquitous Computing 5*, 3 (2001), 169-190.
- [6] Decortis F., Rizzo A. New active tools for supporting narrative structures. *Personal and Ubiquitous Computing 6*, 5-6 (2002), 416-429.
- [7] Di Blas, N., Paolini, P., Sabiescu, A. Collective digital storytelling at school as a whole-class interaction. In *Proc. IDC 2010*, ACM Press (2010), 11-19.
- [8] Druin, A., Stewart, J., Proft, D., Bederson, B., Hollan, J. KidPad: design collaboration between children, technologists, and educators. In *Proc. CHI 1997*, ACM Press (1997), 463-470.
- [9] Druin, A. Cooperative inquiry: Developing new technologies for children with children. In *Proc. CHI 1999*, ACM Press (1999), 592-599.
- [10] Gardner, H, *Frames of Mind*, 2nd ed. Basic Books, NY. 1993, P. 245.
- [11] Healy, J. M. *Failure to connect: how computers affect our children's minds--and what we can do about it*. New York, NY, Touchstone, 1999.
- [12] Inkpen, K.M., Ho-Ching, W., Kuederle, O., Scott, S.D., Shoemaker, G.B.D. "This is fun! We're all best friends and we're all playing": Supporting children's synchronous collaboration. In *Proc. CSCL 1999*, ACM Press (1999), 252-259.
- [13] Ishii, H. and Ullmer, B. Tangible bits: Towards seamless interfaces between people, bits and atoms. *Proc. CHI 1997*, ACM Press 1997), 234-241.
- [14] Lowenfeld, V. and Brittain, W. *Creative and Mental Growth*, 6th ed. Macmillan, New York, 1975.
- [15] Marshall, P., C-H. Cheng, P., Luckin, R. Tangibles in the Balance: a Discovery Learning Task with Physical or Graphical Materials. *Proc. TEI 2010*. ACM Press (2010), 153-160.
- [16] Marshall, P. Do tangible interfaces enhance learning? In *Proc. TEI 2007*, 163-170.
- [17] Raffle, H., Vaucelle, C., Wang, R. and Ishii, H. Jabberstamp: embedding sound and voice in traditional drawings. In *Proc. SIGGRAPH 2007*. ACM SIGGRAPH'07 Educators Program. ACM Press (2007) 32.
- [18] Rosenbaum, E., Silver, J. Singing Fingers: fingerpaint with sound. In *Proc. IDC 20010* ACM Press (2010), 308-310.
- [19] Rosenberger Shankar, T. *Speaking on the Record*. PhD Thesis, MIT Media Laboratory, Cambridge, MA. 2005.
- [20] Topping, K. Cooperative learning and peer tutoring: An overview. *The Psychologist*, 5, 4 (1992), 151-157.
- [21] Zuckerman, O., Arida, S. and Resnick, M. Extending Tangible Interfaces for Education: Digital Montessori - Inspired Manipulatives. *Proc. CHI 2005*. ACM Press (2005), 859-868.
- [22] Wood, D., and O'Malley, C. Collaborative learning between peers: An overview. *Educational Psychology in Practice*, 11, 4 (1996), 4-9.

BulletiNet: Mediated Social Touch Interface for Community Awareness and Social Intimacy

Szu-Chia Lu

GVU Center
Georgia Institute of Technology
TSRB 85 5th St.,
Atlanta, GA 30318 USA
sj.today@gatech.edu

Andrea Kavanaugh

Center for Human Computer Interaction
Virginia Polytechnic Institute and State University
2202 Kraft Drive
Blacksburg, VA 24060
kavan@cs.vt.edu

Copyright is held by the author/owner(s).

TEI'11, Work-in-Progress Workshop
Jan 23, 2011, Madeira, Portugal.

Abstract

BulletiNet is a mediated social touch installation implemented on a 1920x1080 wide touch screen display. It provides two switches of interactive information presentation including the location-based and member-based pages. The users can explore the information of members' work or community events to retain, and enhance, their sense of community awareness through the touch-based interface. Meanwhile, BulletiNet provides asynchronous communication through sketching messages to other community members. Those sketch messages with more personal sense of handmade freestyle writing or drawing make the receivers feel much closer to the senders and bring about certain level of social intimacy among members. Finally, we also discuss some issues and the design trade-offs of BulletiNet.

Keywords

Tangible interaction, design, exploration, work-in-progress, gadget, widget

ACM Classification Keywords

H5.m. Information interfaces and presentation (e.g., HCI): Miscellaneous.

General Terms

Mediated social touch, Community awareness, Social intimacy,

Introduction

Professional research work is communication intensive. Successful collaboration in a work community requires that members maintain awareness of other members. Meanwhile, social Intimacy works as a form of social catalyst among community members to encourage new interactions between them. In this paper, we propose a mediated social-touch installation, called BulletiNet, for a co-located research community to provide community awareness and social intimacy that can increase psychological closeness and improve interaction process among research members.

Successful collaboration in a work community requires that members maintain awareness of each members and the working context [1]. This sense of awareness includes the understanding of who is working with you, what they are doing, and how your own actions interact with others. In the first level, a group of community takes physical proximity to increase the likelihood of impromptu social conversations.

However, even if physical proximity exists, it sometimes fails to yield these advantages. One reason can be the research habits or working schedule of the research colleagues. Therefore, it takes social catalyst to exist within a group to assist in initiating human's interaction.

Social Catalysts is the process by which some external stimulus provides a linkage between people and prompts strangers to talk to each other as if they were

not [2]. Social Intimacy can work as a form of social catalyst among respective community members to encourage new interactions between people located in different spaces. The notion of Social Intimacy [3] describes where the interplay between people and a set of networked objects in a social or public space can be used to create awareness between others, vital connection between groups of people in a public space. It also acts as group lubricant among community members.

Touch can potentially evoke a sense of "proximity and establish the human connection" [4]. Interpersonal touch, called social touch [5], has profound psychological effects on human beings and inevitably affects their experience of social interaction. The technology of mediated social touch interface [6] provides remote communication medium, and also enhance the media richness of interaction. This paper proposed a mediated social touch installation, called BulletiNet. The purpose of this installation is to support the shared sense of community awareness and social intimacy among research community members through a touch screen interface. It indicates the presences of the members and their research interests or current projects, collective events, and research relationship among the members on its display.

Design Concept – Community Awareness

Awareness is the first step of collaboration. One of the purposes of BulletiNet is to maintain awareness of the on-going changes in the environment and attributes of people. Two awareness aspects were taking into consideration in the design of BulletiNet: *Awareness of Place* and *Awareness of People*.

Awareness of place

Ishii claimed that People who share a room create a mental map of the room's arrangement [7]. Therefore, knowing the physical orientation and location of the other collaborators is cognitively beneficial to process other community members' presences information.

Awareness of People

Being aware of the current work context of one another is a core mechanism for initiating a proper conversation to another community member. The awareness of people's presences and activities in a social perspective lays the groundwork for interaction and collaboration.

Design Concept – Social Intimacy

Intimacy relies on communication and sense of closeness. The feelings of closeness are inherent in cognitive, affective and physical aspect of intimacy. Sense of intimacy can exist not only between strong-tie relationships but also within fellow members who share similar working/social context and spaces. Schiphorst and his colleague [3] proposed the notion of social intimacy. They used the cushion as an intimacy object and an intelligent tactile interface to model the social intimacy through techniques in somatics and performance practice.

Mediated Intimacy

The sense of intimacy can be mediated through not only cultural symbols of affection but also shared working spaces as well. "Intimate City" [8] claimed that intimate media plays a role of social platform to connect people in a common ground. These intimate media are collective objects used for communicating personal identities and shared memories/experiences.

Gaver [9] identified three characteristics of mediated intimacy: (i) the designs often make use of evocative materials (e.g. projects within the research community); (ii) mappings are more likely to make use of literary rather than didactic metaphors (e.g. shared research interests); and (iii) objects have a unique physicality (e.g. people seeing almost everyday in a shared work place). These intimate media convey the sense of social intimacy that creates vital connection between groups of people in a shared space.

Mediated Social Touch Interface

Mediated social touch allows community members to use their sense of touch in interaction with and through devices. Touch is the most natural human operation of an object. It can exceed the learning curve of people how to interact with an interface quickly and correctly. The strength of the technology for mediated touch is that it is dynamic [6]. Haans and his colleagues defined mediated social touch as the ability of one actor to touch another actor over a distance by means of technology.

Interface Design

Based on these design concepts mentioned in previous section, BulletiNet was built as a community-based, mediated social touch display to enhance community awareness and social intimacy in a shared space with common social and work context.

The design considerations of BulletiNet includes 1) floor plan as assistance of cognitive mental mapping; 2) presence and relationship information of community members to enhance the sense of awareness and connectedness; and 3) physical mediated social touch

interface to enrich the interaction among fellow members.

Awareness of Place - Physical Floor Plan

The display design of BulletiNet is based on the physical floor plan (see the figure 1). People who share a room create a mental map of the room's arrangement. Therefore, each people know the physical orientation and location of the other collaborators. It clarified the role of place information in informal social interaction. Meanwhile, BulletiNet provides the information of schedules for the meeting rooms in the research center, shuttle timetable to/from the main campus area with real-time bus-coming alert. All of the information is not directly related to the research that members are working on but beneficial to researchers' daily research routine.

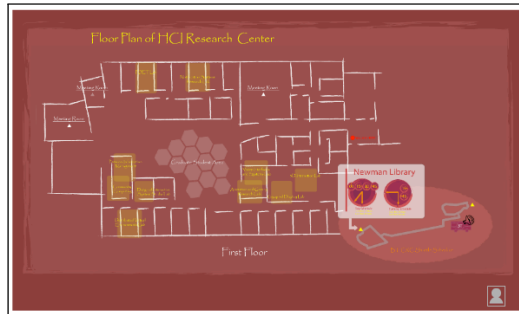

figure 1: Floor plan page on BulletiNet. This page indicates not only the physical direction of labs and office, but also the presence information of researchers and graduate students in their office or lab.

Awareness of People – presence and collaboration info

Not only the general information about the members and work context, BulletiNet also describe the collaboration relationship among community members, including the joint projects and the paper co-authorship (figure 2). The network of collaborative relationship shows the connection among colleagues to encourage both personal and professional sharing and strengthen the sense of connectedness among the members as well.

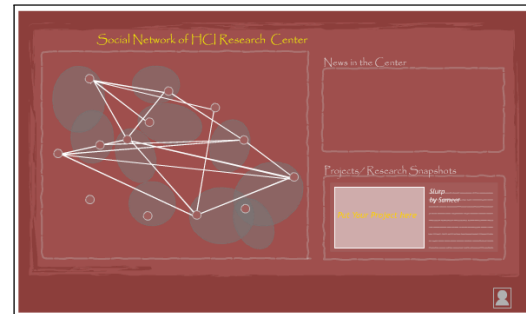

figure 2: The presence information page on BulletiNet. The dots are the community members. The lines connecting the dots are the collaboration networks between community members.

Social Intimacy – Mediated Social Touch

One of the features of BulletiNet is writing the personal sketch messages sent to the community members through the touch screen. The sketch messages provide the handmade freestyle writing and drawing. In one hand, there is no need of keyboard or mouse and, hence, makes the communication operation rapid and convenient. In the other hand, this personal

handwriting increases interpersonal psychological closeness.

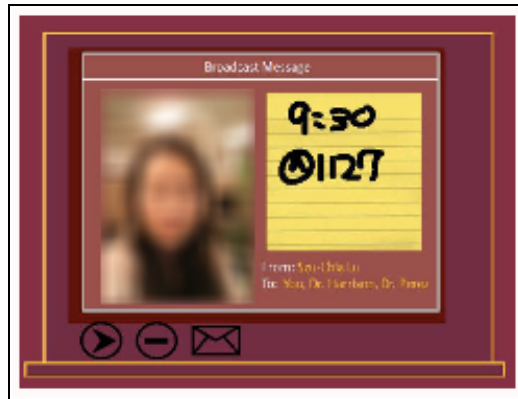

figure 3: Sketch messages with handmade freestyle from other community members.

Installation

BulletiNet is installed in a multi-disciplinary research center mainly focused on Human Computer Interaction (HCI) field. The center located in 1st floor of the research building next to the university and is responsible for education and research at graduate level in Computer Science program of the university. There are about 10 research labs, 25 senior researchers and 40 graduate students sharing the floor. The installation was deployed in a semi-public places, the entrance lobby, inside the research center because of the activity traffic level of accessing to the building.

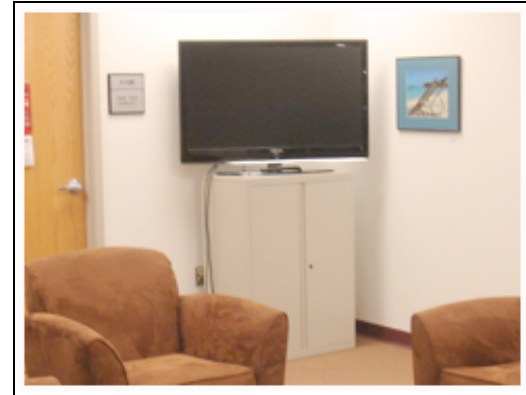

figure 4: Installation location of BulletiNet. In a semi-public and cozy corner next to the entrance of the research center.

Discussion

Social Issue: Privacy Control

Privacy is one big concern about those awareness displays. People are wary of being “tracked”. People prefer their location data being used in certain constrained way. In the design of BulletiNet, one key factor to make this preference acceptable is by sharing location information only around particular places, instead of being universal. This means a group of specific person in a particular space. That’s why BulletiNet is built and installed within the community with a semi-public display. The notion of community-base indicates selective people only; the notion of semi-Public indicates selective place only.

Technology Issue: Design Tradeoffs

Another issue about these awareness displays is distraction. Shared displays are designed to encourage

communication. Unfortunately, informal and spontaneous communication is sometimes disruptive as well as interruptive to productivity. Particularly to knowledge workers, because of interruptions, thinking through important issues can only be in fragmental and short blocks of time. For BulletiNet, a peripheral awareness display, more passive visual presentations are used to prevent the researchers from overloaded information distraction.

Future Work

The user study will be conducted in two parts: behavior observation and interview. The purposes of this study are 1) to enhance the awareness of community members and activities, 2) to demonstrate the sense of connectedness among research individuals or research labs/groups, and 3) to bridge the communication gaps between members with a mediated social touch interface.

Acknowledgements

We would like to thank for the help from the Center of Human-Computer Interaction at Virginia Tech. Thanks for the feedback and suggestion the professors and students gave during the interface design process of this BulletiNet project.

Reference:

- [1] P. Dourish and V. Bellotti, "Awareness and coordination in shared workspaces," in *Proceedings of the 1992 ACM conference on Computer-supported cooperative work - CSCW '92*, pp. 107-114, 1992.
- [2] W. H. Whyte, *City: Rediscovering the Center*, 1st ed. Anchor, 1990.
- [3] T. Schiphorst et al., "PillowTalk: can we afford intimacy?," in *Proceedings of the 1st international conference on Tangible and embedded interaction*, pp. 23-30, 2007.
- [4] A. Montagu and F. W. Matson, *The Human Connection*, Ltr Prtg. McGraw-Hill, 1979.
- [5] E. Goffman, *The Presentation of Self in Everyday Life*. Anchor Books, 1959.
- [6] A. Haans and W. IJsselsteijn, "Mediated social touch: a review of current research and future directions," *Virtual Reality*, vol. 9, no. 2, pp. 149-159, 2005.
- [7] H. Ishii, "TeamWorkStation: towards a seamless shared workspace," in *Proceedings of the 1990 ACM conference on Computer-supported cooperative work*, pp. 13-26, 1990.
- [8] K. Battarbee et al., "Pools and satellites: intimacy in the city," in *Proceedings of the 4th conference on Designing interactive systems: processes, practices, methods, and techniques*, pp. 237-245, 2002.
- [9] B. Gaver, "Provocative Awareness," *Comput. Supported Coop. Work*, vol. 11, no. 3, pp. 475-493, 2002.

A framework for designing and enhancing serendipitous encounters

Ken Keane

Madeira Tecnopolo,
Madeira Interactive Technologies
Institute – University of Madeira
Campus da Penteadá
Funchal, 9000-390, Portugal
ken@m-iti.org

Jos P. van Leeuwen

Madeira Interactive Technologies
Institute – University of Madeira
Campus da Penteadá
Funchal, 9000-390, Portugal
josvl@uma.pt

Valentina Nisi

Madeira Interactive Technologies
Institute – University of Madeira
Campus da Penteadá
Funchal, 9000-390, Portugal
valentina@uma.pt

Copyright is held by the author/owner(s).
TEI'11, Work-in-Progress Workshop
Jan 23, 2011, Madeira, Portugal.

Abstract

In the research outlined in this paper we focus primarily on the potential of technology in fostering serendipity and sense of discovery in public physical spaces. We present two prototypes exemplifying two different approaches on how to investigate and capture users' sense and understanding of the public space in question as well as the use of artifacts and tools in the above-mentioned public environments. The collected insights will offer a basis for discussion on how to co-design technologically mediated experiences together with the user of such spaces.

Keywords

Technologically mediated physical environments, User studies, Participatory design.

ACM Classification Keywords

H5.m. Information interfaces and presentation (e.g., HCI): Miscellaneous.

General Terms

Social media, design

Introduction

Paul Dourish, in his foreword to the book Shared encounters [5] states that "the fundamental character

of ubiquitous computing research is not computational, but spatial." The spatial characteristics of ubiquitous computing are not "merely geometric" but that "inhabit the space as we do, and they structure it and organize it in much the same way as our own activities and movements do. Here the concerns of computer science and technological design intersect with those of geography and urban studies to produce an immensely generative new research area".

We are witnessing a burst of social media focused on mobile applications and services, like Four Square, Gowalla, Open Street, Loopt, to name a few. In the digital spaces/places enhanced by these services, users can now co-create and form communities across time and space. However, although these applications are providing information anytime anywhere, questions about how this influences patterns of behavior through premeditated actions, such as signing into locations or getting recommendations for products and services are a concern.

Related work

Examples of research looking at scenarios are offered by Konomi et al. [10]. They discuss capturing historical data to support verbal and non-verbal communications in social encounters looking at a history-enriched framework for supporting pedestrians' physical distance, movement patterns, and cognitive and social patterns. Embodied in location-relevant blogs and social networks, these support collocated pedestrians using ad hoc networks.

The patterns that Konomi et al. [10] reveal and utilize seem to undermine chance discovery and serendipity in

social encounters. The work we present here aims to examine the role serendipity plays in chance-driven encounters, how it can contribute to the design of technologies that support or even initiate these real events.

Serendipity

According to the online Oxford dictionary, the meaning of "serendipity" is "the occurrence and development of events by chance in a happy or beneficial way". Given in any activity context it is where one has one aim in mind but in the process finds another unexpectedly.

Leong et al. [11] discuss users of technology as actively making sense of the situations they encounter, and using tools to negotiate and create experiences. Seen in this light, users are authors, characters, protagonists, and co-producers [6]. This work positions serendipity within user-experience; where it can be seen as the meaningful experience of chance encounters, where unexpected discoveries can occur. The work analyses how the shuffle experience of music can reveal serendipitous experiences by observing participants' creation of context and fulfilling experiences out of randomly played songs taken out of context.

Shared experience in encounters

Understanding the physical setting where encounters happen helps shape how people interact and define the context. Communication technologies offer other forms of encounters from remote locations that affect the fundamental nature of presence in encounters. Mobile technology is currently driving this by encouraging shared experiences by feeling connected through content creation and sharing. It is through this

awareness and experience of sharing that engages users. Youth cultures' adoption of mobile devices demonstrates this [3].

Shared experience and play

Shared experiences greatly influence play due to the need to establish a space for players. For successful play to take place, context, roles, expectations, and responsibilities need to be defined, which shapes meaning and convention to the encounters [19]. Play occurs unconsciously, consciously, or dynamically [17] and is influenced by a desire for tactile experiences [9].

Bedwell et al. [2] research elements of performance and play with 'Anywhere', an application where participants are guided over the phone by unseen on-the-street performers in exploring an urban area. They analyze the production of paths through content by the performer-participant pair in the city as they access location-based activities and staged performance in multiple locations.

Spatial settings

Considering the role that spatial settings play in shared encounters, Goffman [7] states that our communication and interactions with others can be considered as situated in that they are shaped by both the physical setting and the social situation and that we behave differently accordingly to the degree of both. Meyrowitz [14] says that communication technology now undermines the impact that physical setting has on how we perceive experience in space. McCullough [13] reinforces this by stating that ubiquitous technologies "require new ways of grounding digital information in that they do not undermine ways of acting in the physical world."

Jacucci et al. [8] suggest that the vision of Ubiquitous Computing from Weiser [18] and Abowd and Mynatt [1] have not materialized; that social implication has driven technological innovations rather than making social use the target of design [1]. Their research focuses on materiality that ties together the physical artifacts and embodied interaction and discusses how digital objects and interfaces become props in the social environment, rather than just media to be consumed.

Designing for shared encounters

When considering how to examine serendipity and shared encounters and effectively design for it, suitable non-traditional techniques and frameworks are required.

Paay [15] demonstrates an empirical user-centered approach in studying sociality in the city. She examined aspects of the physical and social context of environment that impact people's experience of place, their interaction with their environment, technology and each other. Then she designed, implemented and evaluated a context-aware pervasive computing system called Just-for-Us.

Diamantaki et al. [4] outline a theoretical framework relating activity theory, actor network theory and embodiment theory.

McCarthy and Wright [12] state that experience is becoming central to our understanding of the usability of technology and present a basis for thinking about and evaluating technology as experience with technological artifacts. They developed an intrinsically connected framework for analyzing experience with

technology consisting of four intertwined threads of experience and six sense-making processes.

Motivations and Observations

Ad hoc behavior of tourists

Of the many visitors that arrive to Madeira each year, those that come by ship are particularly interesting. Tight time constraints put on these tourists means their experience of Madeira is extremely condensed. For those that seek activities, the usual tourist services are often a solution. Interviews conducted with cruise ship tourists choosing not to take part in organized tours reveal that ad-hoc behavior and serendipity are important to people's experiences while discovering new spaces.

Communication between locals and tourists

Tourists travel and seek authentic local experiences, culturally and socially, and this assumption was proven by observations and questionnaires. Residents are often uninterested in interacting with tourists leaving the relationship based on commerce, and value their personal space. They are the source of local information, and stories of the communities they spent their lives in. This presents a wicked problem [16] that involves sharing of local knowledge without sacrifice of private space.

Methodology

By conceptualizing and developing prototypes our research-by-design project aims at developing artifacts and tools that offer people opportunities to discover, interpret, appropriate, and reflect on the social, spatial, cultural, and interpersonal dimensions of encounters. Existing frameworks are used to understand how to capture serendipitous events, shared experiences and

encourage co-design. At this stage we are interested in two experimental approaches that involve the design and development of prototypes that we expose to target user groups.

Prototypes

1. *Exposing users to technology to observe how they appropriate and use the tools provided.*

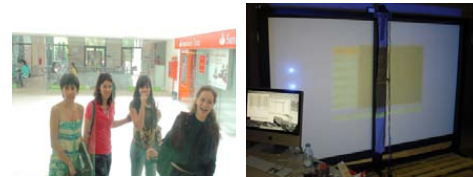

figure 1. First prototyping of "Reflected Spaces."

"Reflected spaces" is an interactive installation centered on people's routines, public spaces and people flow. Focusing on the idea of the "familiar stranger" it offers people the opportunity to reflect about their lives through the social and physical activities that take place in the space over the course of time. For a limited period of time, people's activity is recorded and reflected in real-time as they move past the installation. Eventually the recorded video is overlaid on real-time footage at the exact time the following day. A phone in front of the installation provides a casual means of communication and a tool to record messages, listen and reflect on the experience. Passers-by can explore these recorded messages and the matching recorded video by picking up the phone and listening to what had been recorded last.

Our approach is not to introduce technology that intrudes but to explore the activities that naturally occur in the space and offer people the opportunity to explore and play with them. With “Reflected Spaces” we are interested in re-adjusting people’s notions of the spaces they regularly use.

The first prototype in the entrance hall of the University of Madeira quickly established proof of concept by gauging the level of engagement. Responses were mostly of a curious nature followed by a desire to explore further, though reluctance to fully interact with tools was observed too. This has made us aware of the need to make the experience as intuitive as possible where the user is fully immersed in the experience and artifacts and unaware of the technology that is present. Such insights are aiding refinement of the installation and we are planning further experimentation at various locations.

2. Focus on social context before technology is introduced.



figure 2. Concept and interface design for the “Breadcrumbs” prototype.

Our second prototype, “Breadcrumbs” is an iPhone app that allows users to leave trails of information and

media (virtual breadcrumbs) while exploring spaces. These breadcrumbs can be picked up when found by other visitors of these spaces, exposing them to serendipitous events and share the experiences left by others. To inform the design this application, we will involve users in a series of low-fi experience prototypes in order to determine the way content can be naturally presented and interplay with the users’ real-world activities.

The first iteration will engage a local person (participant one) and a foreigner currently residing in Madeira (participant two). Participant one takes participant two on a route through a neighborhood, showing places and telling stories of interest. Throughout the route participant two is told to spontaneously divert, taking participant one along, off his track. The objective is to observe participants’ experiences of unpredictable events and encourage serendipity through discovery of places, stories, and experiences at locations. Participants will document their experiences using notebooks, a camera and GPS device.

We investigate how people like to explore spaces, what types of unpredictable events unfold and how this influences behavior. Follow-up sessions will discuss and interpret the content created gaining insights to support the development of the high-fi prototype.

Conclusions

New forms of locative media are bringing experiences back into physical spaces. Effective frameworks that establish an understanding of the social, spatial, cultural, and interpersonal dimensions of use, within physical spaces, can inform technological innovations, and our literature review has identified some of these

frameworks. Our experiments will engage users in two different ways, by exposing them to new technologies and by having them enact the process that new technology might incur. We expect that both approaches will inspire the design of the prototypes in complementary ways, leading to concepts that are novel on the one hand and user-centered on the other.

Acknowledgements

The Madeira Life project is co-funded by the regional government of Madeira (MADFDR-01-0190-FEDER_001) and ZON Multimedia. The project receives support from the Madeira Interactive Technologies Institute and the CCM research centre of the University of Madeira.

References

- [1] Abowd, GD and Myatt (2000) "Charting past, present and future research in ubiquitous computing," *ACM Transactions on Computer-Human Interaction*, **7**(1): 29-58.
- [2] Bedwell, B, H Schnädelbach, S Benford, T Rodden, B Koleva (2009) "In Support of City Exploration," *Proceedings of CHI 2009*. ACM Press. Boston, MA, USA.
- [3] Castells M, JL Qui, MF Ardero, and A Bey (2006) *Mobile communications and society*. MIT Press.
- [4] Diamantaki K, C Rizopoulos, D Charitos, and N Kaimakamis (2010) "Conceptualizing, designing and investigating locative media use in urban space," in Willis et al. (eds.) *Shared Encounters*. Springer-Verlag, p 61-80.
- [5] Dourish, P (2010) "Foreword," in Willis et al. (eds.) *Shared Encounters*. Springer-Verlag, p 1.
- [6] Dunne, A (1999) *Hertzian Tales: Electronic Products, Aesthetic Experience and Critical Design*, RCA Computer Related Design Research. 1999.
- [7] Goffman, E (1963) *Behavior in public places; notes on the social occasion of gatherings*. The Free Press. New York.
- [8] Jacucci, G, A Peltonen, A Morrison, A Salovaara, E Kurvinen, and A Oulasvirta (2010) "Ubiquitous media for collocated interaction," in Willis et al. (eds.) *Shared Encounters*. Springer-Verlag, p 23-45.
- [9] Jennings, PL (2010) "A Theoretical Construct of Serious Play and the design of a Tangible Social Interface," in Willis et al. (eds.) *Shared Encounters*. Springer-Verlag, p 153-172.
- [10] Konomi, S, K Sezaki, and M Kitsuregawa (2010) "History enriched spaces for shared encounters," in Willis et al. (eds.) *Shared Encounters*. Springer-Verlag, p 47-60.
- [11] Leong, TW, F Vetere, and S Howard (2005) "The Serendipitous Shuffle," in *Proceedings of OZCHI 2005*, Nov. 23 – 25, 2005.
- [12] McCarthy, J, P Wright (2004) "Technology as Experience," *Interactions*, Sep./Oct. 2004: 42-43.
- [13] McCullough M (2005) *Digital ground*. MIT Press.
- [14] Meyrowitz J (1986) *No sense of place: the impact of the electronic media on social behavior*. Oxford University Press, USA.
- [15] Paay, J (2005) "Where we met last time," *Proceedings of OZCHI 2005*. Nov. 23 – 25, 2005.
- [16] Rittel, HWJ and MM Webber (1973) "Dilemmas in a General Theory of Planning," *Policy Sciences*, **4**(2): 155-66.
- [17] Stukoff M (2010) "Bluetooth as a playful art Interface," in Willis et al. (eds.) *Shared Encounters*. Springer-Verlag, p 127-150.
- [18] Weiser M (1991) "The computer for the 21st century," *Scientific American* **265**(3): 94-104.
- [19] Willis, KS, G Roussos, K Chorianopoulos, and M Struppek (2010) *Shared Encounters*. Springer-Verlag.

Marking the moment: Coupling NOOT to the situated practice of creative sessions

Jelle van Dijk

Eindhoven University of
Technology & Utrecht University
of Applied Sciences
Oudenoord 700, 3513 EX
Utrecht, Netherlands
jelle.vandijk@hu.nl

Remko van der Lugt

Utrecht University of Applied
Sciences
Oudenoord 700, 3513 EX
Utrecht, Netherlands
remko.vanderlugt@hu.nl

Kees Overbeeke

Department of Industrial Design,
Eindhoven University of
Technology
Den Dolech 2, 5612 AZ
Eindhoven, Netherlands
c.j.overbeeke@tue.nl

Copyright is held by the author/owner(s).
TEI'11, Work-in-Progress Workshop
Jan 23, 2011, Madeira, Portugal.

Abstract

Based on the theory of *embodied cognition* we developed NOOT, a tangible tool that allows marking audio-moments during creative sessions. A detailed analysis of using NOOT in practice led to a re-conceptualization of NOOT within processes of *external scaffolding*. It also spurred a new design project focused on reflection during group sessions.

Keywords

Embodiment, Scaffolds, Practice, Tangible, Research-through-design, Prototype, Creative session, Reflection

ACM Classification Keywords

H.5.2 Information interfaces and presentation: User Interfaces.

Introduction

This work started with two observations from practice:
1. During creative sessions, many good insights get lost
2. Participants often misunderstand one another.

We combined these with the idea that sense-making is a strongly situated activity, emerging from social interactions, with physical elements in the environment functioning as 'external scaffolds', based on [6], [4].

Scaffolds in the creative session

In an earlier study [7] we noticed how physical materials such as post-its and sketches, created in

group sessions, work as 'scaffolds' for sense making: Scaffolds work as shared focus points and referential objects around which sense making conversations take place [cf. 3, 4, 8].



Figure 1, Left: A creative session in our 'Conceptspace'.

With this in mind we developed NOOT [7] over several iterations to a fully working prototype. In this study we were interested in the details of how NOOT becomes coupled [6], over time, to people's activities of external *scaffolding* [4] as part of the overall process of sense making in creative group processes. But first, the prototype.

NOOT

NOOT is a system of wireless tangibles combined with central audio recording and playback. The prototype consists of a set of eight hockey-puck sized disks that can be attached to post-it notes or sketches (Figure 2). When somebody writes an idea on a post-it and discusses it s/he attaches a NOOT to it and puts it away. When paper is attached, a wireless signal (Arduino-mini + RF transmitter) sets a time-marker in an audio recording of the entire brainstorm session. Pressing the button on a NOOT plays back 20 seconds of the recording evenly divided around the time

marker. Originally we suggested NOOT *enriches* cognitive scaffolds such as post-its or sketches with audio-context and is part of a 'situated memory' [7], cf. [8]. That is, we did not see NOOT as a storage medium in isolation. Instead audio-fragments *augment* the scaffolding power of physical materials. This is why NOOTs are literally clipped to a post-it or sketch.



Figure 2: Noot in its context

Embodied Cognition

This study is part of a larger investigation into how Embodied Cognition (EC) may provide new meanings for tangible interaction design [4],[5],[6]. EC stresses the way tools, physical materials and social processes all work in concert in order to support sense-making processes. (For introductions see [1],[3],[6],[8])

Coupling

The notion of *coupling* is central in EC. It is the process whereby human beings evolve stable behavioral patterns resulting from continuous interactions between brain, body and environment. Clark [4] explains how action is geared towards “maintain[ing], by multiple ... adjustments ... a kind of adaptively potent equilibrium that couples the agent and the world together”. Merleau-Ponty [9] discusses how perception and action become coupled, working towards of a state of ‘optimal grip’. Dourish [6] situates coupling in a socio-technical perspective. He explains how technologies must be “appropriated and incorporated as a part of a specific set of working practices” (p. 171). “[E]mbodied technologies can only have meaning through the way in which users incorporate them into working practices” (ibid, p. 172). Designers can therefore suggest, but never *determine* couplings (ibid). In the present study we investigated how such *couplings* evolve between NOOT and the scaffolding practices of participants in a creative session.

Method

We observed seven successive one-hour brainstorm sessions involving students in design projects and recorded video. (Projects had external clients). Groups visit our creative space only once a semester, so we couldn't track one group over multiple sessions. Instead we investigated coupling in an indirect way, contrasting 1) detailed observations of the behavior of one professional *facilitator* (*F*) who lead all seven brainstorms; 2) *F*'s changing personal views on NOOT and 3) our own, evolving, thoughts as designers [cf. 2]. We decided to look at the use of NOOT through *F*'s eyes and actions. For instance, we looked at how the facilitator would

introduce NOOT in each next session, how he would himself use NOOT or encourage participants.

The facilitator

F is involved in co-design projects, often with multiple stakeholders. Session facilitation is a regular part of his job. *F* had not been involved in designing NOOT. We showed *F* how to operate NOOT while he was preparing for the first session, explained the idea of audio being a context to the physical post-its. After each session we interviewed *F*.

Data analysis

After each session two observer-designers integrated new findings using a grounded theory approach [11]. We focused on when and how NOOT was used and how interactions with the prototype were situated in the social and physical context. After session five we confronted the facilitator with our initial findings. More on this below.

Results

The routine of using NOOT consists of several phases:

Marking the Moment

- *Opportunity for marking.* *F* steps back from the process and observes (listens to) the conversation. An opportunity for using NOOT arises.
- *Prepare to mark.* *F* walks over to where NOOTs are located, grabs one and a sheet of empty paper (A5). *F* waits with both items in hand and listens, or walks back to the group activity and waits there.

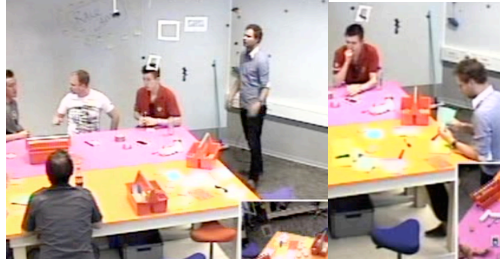

Figure 3, left: Opportunity for Marking, right: mark the moment

- *Marking the moment.* F puts the paper in the NOOT at a carefully chosen moment.
- *Position.* F positions NOOT on a suitable place the table or on the whiteboard.



Figure 4. *Position.* A NOOT taped onto a pencil box by F, creating a personal 'dashboard' (left). NOOT as part of a post-it cloud on the whiteboard wall (right).

Playback

- *Playback opportunity.* F walks over to used NOOTs for playback.
- *Activating playback.* F presses the replay button.

- *Listening.* Participants would listen to the playback as a group, sometimes being disturbed by it.
- *Acknowledgement* After playback ends, the group acknowledges this by a reaction.



Figure 5. Activating Playback

Discussion

NOOT as enhancement of post-its?

We designed NOOT as a tool that you would clip on to a post-it and that the audio would strengthen this external scaffold by providing context [7]. NOOT was not used this way. Instead, *activating* NOOT meant 'marking *this moment*' which stood apart from particular external scaffolds such as post-its. This could be seen from the fact that F did not attach a NOOT to an existing post-it, but first used a NOOT to 'catch' a piece of conversation - using an empty paper to activate it - and then he would write something on the clipped paper by means of a label.

Scaffolding is positioning

We designed activating NOOT *and* coupling it to a scaffold as one action. In reality these are two actions. 'Marking the moment' is not related to external

scaffolds. External scaffolding comes into play during 'positioning', for instance when NOOT put on the whiteboard in relation to elements in a mind-map (figure 4, right) or, for instance, F carefully positioned several NOOTs before him on the table. F came to be quite creative in positioning (figure 4, left) and in personal way, as in: 'this is one of mine'.

A moment of reflection

In contrast to our original concept, NOOT was not used by the person uttering something important. F came to use NOOT mostly when stepping *outside* of the conversation, taking a reflective stance. NOOT also afforded an *anticipatory* attention. F would always be listening to the talk in order to sense an *upcoming* opportunity for making a 'good mark'.

Changing views of NOOT

Contrary to our explanation, at the start F still treated NOOT as a storage medium for ideas, which was precisely what we did not want. He tried to catch the 'core of an idea' (his words) from a participant's natural speech. This proved to be an effortful challenge. F was often afraid that 'the right information' would be missed:

F: "You're constantly thinking about the timing, that 10 seconds before and after, it sounds really short but it really is quite a long sample, but you are wondering, did I record it or not?"

This may have to do with a facilitator being focused on results. Ideas are seen as *objects* that need to be stored as products of the session. Another reason is that facilitators are always focused on time, especially how much of it is left. Moreover, the 20 seconds 'sample time' might provoke a container metaphor, where the implicit task is to get the right stuff inside the container.

In the confrontation with F we asked F to look at his strategy in relation to several general themes that had emerged from his behavior. This helped F in exploring new ways of using NOOT and getting out of his frustration. F then evolved a smooth routine for 'marking interesting moments of conversation', as is shown in his behavior. A typical *Opportunity for Marking* in the session one was this:

F, standing at the whiteboard, asks S3, pointing at a post-it note, "And that market, would you like to focus on all markets, or only the housing market, and why that one in particular?"

S1, interrupting, "I think it would be cool to..."

[F quickly takes a NOOT and a piece of paper]

"...look a bit into that market"

[F clips a paper into NOOT and walks back to the table with the participants]

"... well, you have now the public-transport bike and some companies have their own bikes"

In session six the typical *Opportunity for Marking* would be to mark 'moments' of conversation instead:

F: "What did you do yourself when you were at that age?"

S1 "I played with marbles"

[Laughing]

S2 "I was really the Flippo guy [Flippo's were 90's gadgets that came with a bag of crisps]

[More laughing]

F asks some more questions, offers a memory of himself and then the group is suddenly in a flow, with all participants are actively recollecting past experiences, anecdotes, opinions, associating on the basis of what another person said, interrupting each other frequently. The general focus is on kinds of play they used to like as kids.

F now steps aside, listens to the conversation, then clips a paper in NOOT and puts it on the table.

Playback

Playback was not used often. We observed that centrally played audio demands full attention of the whole group, which was often disturbing instead of

helpful. We consider making playback also individually possible, such that a participant may choose to experiment with it without directly disturbing others.

How NOOT couples to the practice

In conclusion, we see NOOT as a tool by which one has new ways of making personal, reflective statements: 'I find *this* moment interesting, we might need to revisit it later.' Such mini-moments of reflection-on-action can be of great value for creating a deeper insight with respect to the task at hand [10]. Through marking and positioning, this reflective action becomes socially *accountable* [6, p.79]: *I see you 'marking this moment', which may cause me to reflect as well: 'What is so important about this moment?'*. On the interaction level, NOOT provides tangible 'entry-points' to the complete audio stream. The user should therefore be able, upon entering the stream through a NOOT, to scroll back and forth, given his current need.

Further directions

Our detailed study of the use of NOOT provided valuable insights on how coupling evolves in practice. Our study also put attention to the *social* dimension of scaffolding practices. Using NOOT is personal. It involves 'marking *my* moment', and different people will have different needs for marking and playback. In general, ideas and insights are always entertained by someone, loved by someone, defended or critiqued by someone. We have used this insight as a starting point for a new design project focusing on the way personal 'traces of activity' can be used for reflection in groups.

Acknowledgements

We wish to thank Marnick Menting, Jens Gijbels and Johan Groot-Gebbinck for their valuable work.

References

- [1] Anderson, M.L. Embodied cognition: a field-guide. *Artificial Intelligence*, 149, 1 (2003), 91-130.
- [2] Blomberg, J. and Giacomo Andrea, J. Ethnographic field methods and their relation to design. In: Schuler, D., & Namioka, A. (Eds.), *Participatory design: Principles and practices*. Lawrence Erlbaum Associates, Hillsdale, NJ, USA, (1993), 123-155.
- [3] Clark, A. *Being there: Putting brain, body and world together again*. MIT Press, Cambridge, MA, (1997).
- [4] Clark, A. An embodied cognitive science? *Trends in Cognitive Sciences*, 3, 9, (1999), 345-351.
- [5] Djajadiningrat, J.P., Wensveen, S.A.G., Frens, J.W. and Overbeeke, C.J. Tangible products: redressing the balance between appearance and action. *Personal and Ubiquitous Computing*, 8,5, (2004), 294-309.
- [6] Dourish, P. *Where the Action Is: The Foundations of Embodied Interaction*. MIT Press, Cambridge, MA, (2001).
- [7] Dijk, J., van Lugt, R. van der and Overbeeke, C.J. Let's take this conversation outside: supporting embodied embedded memory. *Proc DPPI'09*, ACM Press (2009), 1-8
- [8] Hutchins, E. *Cognition in the wild*. MIT Press, Cambridge, (1995).
- [9] Merleau-Ponty, M. *Phenomenology of perception*. Routledge, New York, (1962).
- [10] Schön, D.A. *The reflective practitioner - how professionals think in action*. Basic Books, New York, (1983).
- [11] Strauss, A. and Corbin, J. *Basics of qualitative research. Grounded theory, procedures and techniques*. Sage, London, (1990).

DUL Radio: A light-weight, wireless toolkit for sketching in hardware

Martin Brynskov

brynskov@imv.au.dk

Rasmus B. Lunding

rasl@cs.au.dk

Lasse Steenbock Vestergaard

lassesvestergaard@gmail.com

Information and Media Studies
Center for Digital Urban Living
Aarhus University
Helsingforsgade 14
DK-8200 Aarhus
Denmark

Abstract

In this paper we present the first version of *DUL Radio*, a small, wireless toolkit for sketching sensor-based interaction. It is a concrete attempt to develop a platform that balances ease of use (learning, setup, initialization), size, speed, flexibility and cost, aimed at wearable and ultra-mobile prototyping where fast reaction is needed (e.g. in controlling sound). The target audiences include designers, students, artists etc. with minimal programming and hardware skills. This presentation covers our motivations for creating the toolkit, specifications, test results, comparison to related products, and plans for usage and further development.

Keywords

sketching, toolkit, ultra-mobile, wireless

ACM Classification Keywords

H.5.2 [Information Interfaces and Presentation]: User Interfaces—prototyping; C.5.3 [Computer System Implementation]: Microcomputers—microprocessors

General Terms

hardware, prototyping, interaction design, tools, teaching

Copyright is held by the author/owner(s).

TEI 11, January 23, 2011, Madeira, Portugal

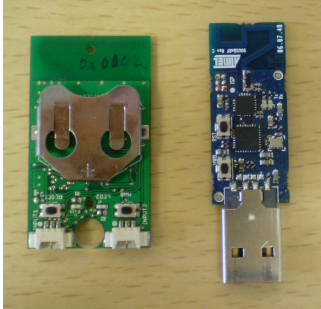

Figure 1. The DUL Radio board (left) and receiver (right). The board measures 2.5 x 4.3 x 0.6 cm (1 x 1.7 x 0.2 inches) including antenna, two analog ports, an accelerometer, and a battery (3 V lithium cell) – compare to the standard USB Type A plug (right).

Introduction

One of the main obstacles in tangible and embedded interaction design is the complexity of tools and competences required for sketching and casual prototyping. Whether for educational[1], designerly[2], or artistic[3] purposes, various other projects have addressed this challenge, and a range of tools and platforms have emerged. *DUL Radio* (Fig. 1) is a concrete attempt to develop a platform for sensor-based interaction design that is both (a) easy to use and (b) has a specific feature set not typically present in a single, unified system.

Ease of use applies to the point of view of the prospective interaction designer (whether formally trained or not): no steep learning curve, easy initialization and set-up, requiring no or minimal programming skills or hardware experience. Thereby, we aim to accommodate users who are not (yet) technically skilled, typically designers, students, and artists.

The feature set of any platform represents trade-offs as a result of different developer traditions, standards, needs, end-product perspectives, and even ethics. But in general, the development environments tend to favor either ease of use or low-level hardware control.

DUL Radio seeks to balance size, speed, flexibility, and cost optimized for wearable and ultra-mobile prototyping scenarios where fast reaction is needed (e.g. in controlling sound and triggering events). It aims to be efficient and flexible while still favoring ease of use.

Specifications

DUL Radio consists of a hardware kit and an accompanying software part.

Hardware

Hardware-wise, the toolkit is made up of

- a wireless data-transmitter (the DUL Radio board),
- a receiver (standard product)[4],
- various sensors.

SENSOR BOARD SPECIFICATIONS

- Physical size: 2.5 x 4.3 x 0.6 cm (1 x 1.7 x 0.2 inches) including antenna, two analog ports, an accelerometer, and a battery.
- Power: 3 V lithium cell.
- Processor: Atmel ATmega168.
- Transceiver: Nordic nRF24L01 (2.4GHz).
- Accelerometer (ACC), digital: Analog Devices ADXL345 (3D g-force, tilt, single/double-click, and free-fall).
- 2 x 10 bit analog input ports (ADC).
- Optionally one of the analog input ports can switch to a pwm-controlled output (not implemented in the current version).

Each receiver can communicate with up to 4 sensor boards simultaneously (multi-performer operational), thus giving a total of 8 analog inputs + 4 ACCs per receiver. Since the sensor board is equipped with transceivers (capable of transmitting as well as receiving), DUL Radio can potentially be used for node-based setups, were the transmitters are turned to stand-alone data-handling entities, that communicate in chains or groups and make decisions based on on-board code. It can be developed to meet the ZigBee standard. See Fig. 2 for a test setup.

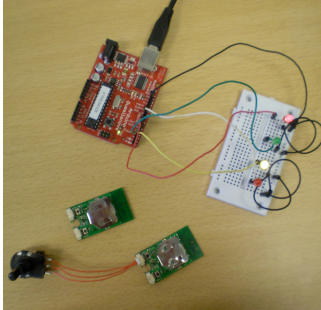

Figure 2. Test setup. Two sensor boards (bottom/middle), one with an external sensor (potentiometer, far left) transmitting wirelessly to a laptop with a receiver (not visible). The signal is sent via the laptop to an Arduino board (top) which is connected to four LEDs. The LEDs represent the state of the two accelerometers and two analog ports.

Software

The software in the toolkit can be separated into two groups: development software (bootloader etc. for the platform) and the user interface (for the interaction designer).

DEVELOPMENT SOFTWARE

The DUL Radio features a custom built bootloader and other pieces of software to make the basic functionality and configuration accessible in a convenient way. Parameters that can be set in software include:

- de/activate ports (ADCs, ACC)
- wake mode (by ADC, ACC or both)
- threshold for wake, timeout for sleep
- data format (binary or ASCII)
- sample rate
- choose transmitting radio channel

Apart from the software that is required for basic functionality, additional software can be developed and downloaded to the EEPROM on-board.

USER INTERFACE

The Ease of use-aspect essentially deals with the development of the interface through which the user configures and controls the hardware. PicoBoard[5] using the Scratch programming interface is a notable example of an easy-to-use interface to embedded programming.

The DUL Radio targets adults who know how to operate computers and use ordinary application software, thus

the user interface does not have to be overly simple, but it should allow the user/designer to focus on the essentials: The design-process and realization through triggering of events and handling of sensor/actuator data.

The sensory-data transmitted is made available to the receiving system on a serial port. The current setup uses a standard Type A USB receiver attached to a laptop (Mac, Linux or PC works fine), but that could as well be any other USB host-enabled device, e.g. an Arduino or a USB On-The-Go-enabled[6] mobile phone (e.g. Nokia N8). The data can then be picked up by any application capable of listening to a serial port, e.g. Processing or a Java program.

For our purposes, and at this early stage, we are using the Max[7] environment which is widely used by audio designers and performance artists. In order to test the platform, a java-external handling the data-strings and three simple Max patches were developed (Fig. 3-5).

Tests

We have run a series of initial performance tests on the first version. The sensor boards will run about +5 days (+120 hours) with continuous wireless data transfer from the two ADCs running at 50 Hz. This is a high-performance scenario. With only ACC on and lower transfer rate, battery life will be considerably longer. The antenna range is about 10-15 m (30-50 feet) indoor (with lots of RF devices around) and 45-70 m (150-230 feet) outdoor.

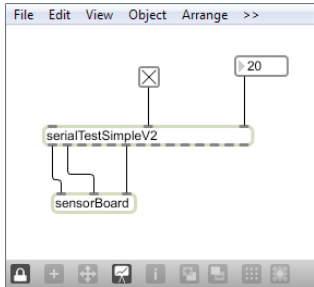

Figure 4. This patch connects the patch that handles sensor board input (Fig. 3) and the patch that handles output to an Arduino board.

Figure 5. This patch converts the data from the sensor board to numbers that the Arduino board understands and sends it to the Arduino board.

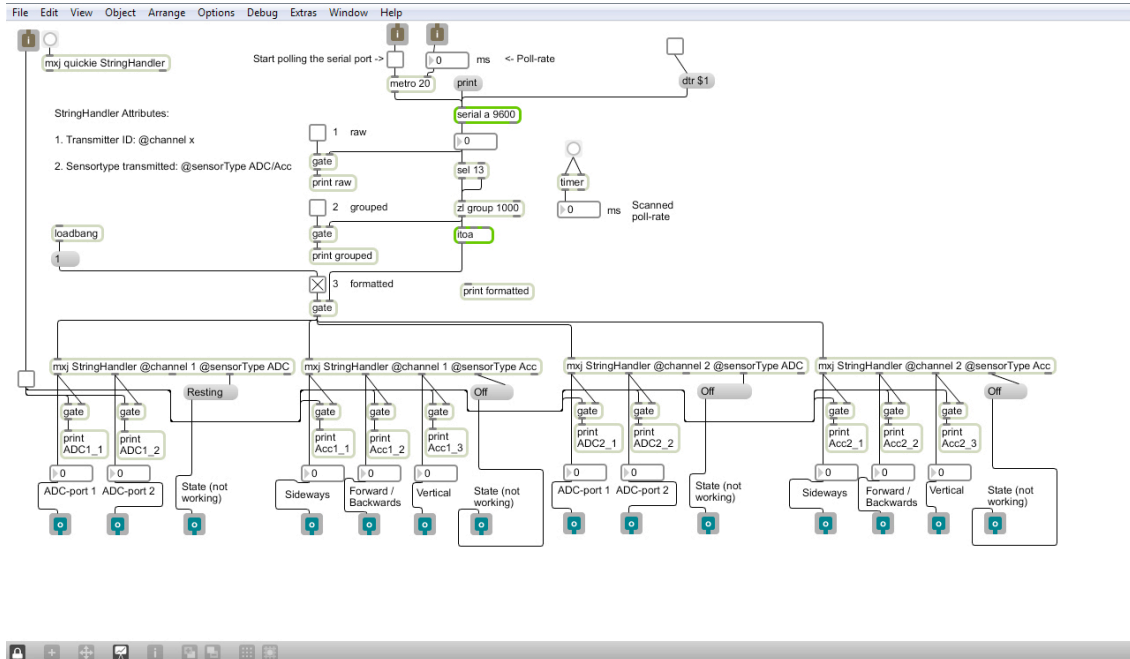
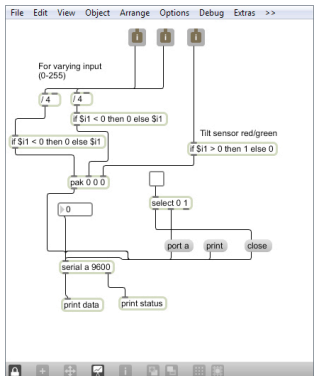

Figure 3. Max[M7] patch that gets input from the sensor board, separates ADC from ACC data and sends the split data to specific outlets. See also Fig. 2 (above) for the physical setup.

Comparison with related products

In 2006, addressing a design issue requiring data communication from several moving sensors in a room (equipped in shoes) wirelessly and at a fast rate (fast enough to track step-dance-like behavior) and small enough to build into the shoes so no visual cue would reveal the embedded enhanced features of them, we realized that such a design task was not easily met with off-the-shelf products. Mobility, pervasiveness, and size were key features, so constructing a responsive floor-layer was not an option. A system designed to address this and similar tasks was not readily available to us. So we had to build our own.

We made an early prototype system which supported the task. It consisted of several small transmitter units equipped with one analog input transmitting to one central receiver. The system described in this paper is a semi-standardized and generalized product designed with the early prototype system as an inspiration, and with the aim of addressing the two key areas: ease of use and the specific features we needed. One might add, that in order to be useful in teaching, it should also be available in large quantities and at a reasonable price. Four years is many life-times in terms of technological products. Our updated survey reveals that products once marketed with success are now obsolete, and new products have entered the market. As it turns out, a 1-to-1 comparison is not possible. Different design features are favored over others in the different products. But an attempt to compare relevant products shows the following systems, grouped in two categories.

Products based on the IEEE 802.15 classification of wireless personal area networks (WPAN) – primarily Bluetooth (IEEE 802.15.1) and ZigBee (IEEE 802.15.4) – are

typically systems that are prepared for OEM products or prototyping schemes. Power-consumption, advanced time-out algorithms, and on-board sensors are attractive features. However, the usability for non-programmers and non-engineers is next to none. We shall call this category "Middleware". Comparatively, searching for consumer-oriented products that meet our needs are also in vain. These products focus on ease of use but are typically not equipped with power-saving features, wireless RF data transmission etc. We shall call these plug-and-play solutions "Off-the-shelf products".

The following is a list of products and platforms available on the market relating to DUL-Radio:

Off-the-Shelf products (as of nov. 2010)

- **Eowave: eobody2 hf:** Wireless interface with 16 sensors per transmitter, 1 transmitter per 1 receiver. 12 bit, meets IEEE 802.15.4 (ZigBee) standard. Size: Large (pouch size: 105 x 95 x 10 mm, board size: 6.5 x 6 x 1 cm incl. battery). Battery lifetime: not estimated.
- **Eroktronix: MidiTron:** Wireless Interface to MIDI. Up to 10 analog or 20 digital inputs, 900 MHz FM (not ZigBee), 10 bit. Size: Transmitter ca. 6 x 3.8 x 3.8 cm (incl. battery). Battery lifetime: not estimated.
- **Infusionsystems: Wi-microDig:** Wireless Bluetooth interface, 8 analog inputs, 10 bit. Size: 2.5 x 2.5 x 8 cm (incl. battery). Battery lifetime: estimated to 4 hours (9 V).

Middleware (as of nov. 2010)

- **avrfreaks: iDwaRF:** Sensor-node for wireless sensor networks.

- **TECO PARTICLE: zPart:** ZigBee, prepared for add-on sensors, formerly Smart-Its. Size: 3.5 x 2.8 cm.
- **gumstix: Overo Wireless:** Multifunctional interface with 6 analog inputs, 6 pwm-outputs, camera input, based on Overo Fire, bluetooth or FM (900 MHz). Size: 5.8 x 1.7 x 0.4 cm (without battery), no direct connections; needs external modules for sensors etc.
- **Phidgets SBC:** Fully functional single-board computer, 64 MB RAM. 8 analog inputs, 8 pwm-outputs, 8 digital ports. Wireless connection based on 900 MHz FM. Size: no measurements, but relatively big.

Arduino

An obvious candidate is the Arduino platform which we would categorize as in between middleware and off-the-shelf. It is not that easy to use, and wireless setups require extra components.

- **Arduino Fio:** The Fio is a controller equipped with 8 analog inputs (10 bit), 14 digital inputs (of which 2 can be flipped to pwm-outputs). Not wireless. Like Arduino boards in general, an Xbee ZigBee transceiver-module is required, and another Xbee must be used. Size: 6.8 x 2.8 cm (not incl. battery). There are other categories, e.g. teaching and highly specialized OEM systems (weapons, tracking etc.) which we have looked at but not found fulfilling.

Conclusion and future development

We have presented the DUL Radio which is now in version 1. It aims to be easy to use for tech novices while still retaining a feature set only found in less accessible products, according to our survey. The toolkit has reached a level of hardware maturity where we can begin to scale up the prototyping workshops and use it in teaching. With a

scheduled larger-scale production, the price will come down. At the moment, production and handling is relatively expensive, while the components are fairly cheap. After a phase of field testing, we will consolidate the prototypes on the user interface software, moving from ad hoc Max patches to better designed applications. We look forward to getting feedback on the platform, both from our internal use and from others.

Acknowledgements

Our sincere thanks to Jesper Nielsen and Jacob Andersen at the Alexandra Institute who did much of the development. Research funded by the Danish Council for Strategic Research, 09-063245, (Digital Urban Living) & EU Regional Fund/Ebst.dk grant 08-0018.

References

- [1] Resnick, M., Martin, F., Sargent, R. and Silverman, B. Programmable bricks: Toys to think with. *Ibm Syst J*, 35, 3-4 (1996), 443-452.
- [2] Gross, M.D. and Do, E.Y.-L. Demonstrating the electronic cocktail napkin: A paper-like interface for early design. *Proc. CHI 1996*. ACM (1996), 5-6.
- [3] Mellis, D.A., Banzi, M., Cuartielles, D. and Igoe, T. Arduino: An Open Electronics Prototyping Platform. *Proc. CHI 2007* (2007)
- [4] Atmel, ATAVRUSBRF01 USB 2.4 GHz, http://www.atmel.com/dyn/products/tools_card.asp?tool_id=4322.
- [5] Playful Invention, PicoBoard, <http://www.picocricket.com/picoboard.html>.
- [6] USB On-The-Go, <http://www.usb.org/developers/onthego/>.
- [7] Cycling '74, Max, <http://cycling74.com/products/maxmspjittr/>.

Towards Collaborative System Based on Tiled Multi-Touch Screens

Vít Rusňák

Masaryk University
Botanická 68a
Brno, Czech Republic
xrusnak@fi.muni.cz

Lukáš Ručka

Masaryk University
Botanická 68a
Brno, Czech Republic
xrucka@fi.muni.cz

Abstract

In this paper, we propose some preliminary outcomes concerning a design of a collaborative environment which will support group-to-group collaboration over shared content (applications, text-based documents, visualizations, etc.) based on distributed tiled multi-touch screens as the main interface. The design will support interactive work in local groups using one tiled touch-screen based on distributed rendering nodes, as well as cooperation of two or more geographically dispersed groups where the shared content (deixis) is distributed across several tiled touch-screens and implicitly synchronized.

Keywords

Design, Tiled Multi-Touch Screen, Group Collaboration
Distributed Collaborative Environment

ACM Classification Keywords

H.5.2 User interfaces – Input devices and strategies,
Interaction styles

H.5.3 Group and Organization Interfaces – Collaborative computing, Synchronous interaction, Computer-supported cooperative work

Copyright is held by the author/owner(s).
TEI'11, Work-in-Progress Workshop
Jan 23, 2011, Madeira, Portugal.

General Terms

Design, Distributed Collaborative Environment

Introduction

There is growing need for sharing knowledge and experience through a cooperation of scientific teams. This cooperation can be seen from two perspectives – collaboration of members in a local group and collaboration of geographically dispersed groups. We can also consider both cases together. In all these cases, cooperating teams usually want not only to communicate but also to collaborate over some data. They need to discuss their presentations, experiment results, schemes, etc. and/or produce them. However, creating group-to-group collaborative environment as a combination of communication component (e.g., using video-conferencing systems) and content sharing¹ component still remains very challenging task.

We want to focus on tightly-coupled rendering clusters (i.e., clusters with high-bandwidth low-latency network links) supporting distributed tiled screens such as SAGE [1], as well as geographically dispersed nodes interconnected by high-latency with high-bandwidth or low-bandwidth available. The advantage of tiled screens is very high resolution in order of tens of megapixels, which is much higher than using single big screen². User can visualize images having huge resolutions natively 1:1, e.g. maps or electron microscope imagery. Such huge resolutions allow the user to study image details without losing the context of a whole.

¹ As content we consider both documents and applications. Term *deixis* is used for such content.

² Common resolution even for big displays is 1920x1080 pixels.

Concept of a distributed environment makes current algorithms for gesture recognition insufficient, because they are not able to process multi-touch gestures with strokes that are spread over multiple devices. We intend to develop new gesture recognition algorithms suitable for a distributed environment with multiple users. To ensure system interactivity even for geographical dispersed nodes we also need novel high-speed protocols for data synchronization of the different collaborating locations.

Within this context, we are working towards the design of a new distributed collaborative environment based on tiled screen architecture which will be gesture controlled. The environment is intended as a group-to-group workspace with the native support for deixis. The main goals of the project are:

- To create a framework for general gesture description in a distributed environment where the gesture could be spread across multiple nodes
- To develop gesture-recognition in a distributed environment while gestures can be generated by multiple persons at the same time
- Integration with existing collaborative systems and applications together with the protocols for synchronization of geographically dispersed collaborating locations

This paper introduces the key aspects of the system for group-to-group collaboration we are currently working on. The prototype that we made demonstrates feasibility of the gesture recognition in distributed environment which is considered as one of key aspects of a system design presented in this paper. Since we are at the ear-

ly stage of the development, it has a very limited functionality of simple gesture recognition in distributed environment of tiled screens only and gestures have no semantics yet.

Design Challenges

Main ideas that we intend to apply in our project are described in this section. Short discussion of technical and technological aspects is followed by challenging objectives tied to distributed environment we want to reach.

From the hardware perspective, we use the concept of SAGE - the visualizing cluster - where the individual computing nodes are interconnected through an optical network. The ordinary LCDs will be provided with multi-touch sensors or substituted completely for the screens with built-in multi-touch support. As a multi-touch sensor, we are considering using some kind of available capacitive, optical or nano-wired polymer technology.

Additionally, some other kind of sensors (probably based on green laser) will be used as an extension of touch-based control. This would enable simple 3D gestures (e.g., resizing or replacing displayed objects) when standing several steps from the wall. This would allow our environment to expand beyond its 2D limitations.

The intended environment is basically locally distributed system. In such an environment, existing algorithms for gesture recognition are insufficient because they are designed for gestures produced within one device but we consider gestures spread over multiple screens which are potentially attached to different computing nodes. This requires new approaches in developing dis-

tributed gesture recognition algorithms where the synchronization and data exchange between computing nodes become essential parts. Since the system is meant to be interactive, the speed of recognition and on-the-fly processing of gesture semantic are demanding features as well.

Another challenging task is to differentiate gestures of different people working within the same workspace. One of the system requirements is make it as unobtrusive as possible. The user should come and start to work free from neither an initialization nor a login process. Thus, we consider using cameras installed on the top and the side of the display wall to enable spatial recognition of individuals. The other utilization of information obtained from cameras should be useful for cooperation of geographically dispersed nodes. The position of the people from remote places will be visualized in a form of hand shadows directly on a screen. This would provide basic notion about the actions that other users intend to perform.

Distributed multi-touch sensor design requires precise synchronization of touch interactions from all the users. Also the gesture processing places high demands on low latency and gesture evaluation order which are both crucial to prevent inconsistency during the work. It is necessary to develop a set of specialized networking protocols which fulfill these requirements and make the system interactive.

Proof of Concept

We have made a prototype application for the experiment purpose. The application is able to recognize three situations: (i) gesture is spread over multiple screens; (ii) multiple events performed within a certain

time limit is correctly recognized as one gesture; (iii) two (or more) gestures are recognized when time limit is exceeded. Consecutive informal experiment supports our expectations and shows that our approach provided straightforward gesture recognition in a distributed environment (without any gesture semantics for now).

As we had been waiting for new pieces of hardware at the time of writing this paper, we used components we already had available. We build a simple distributed environment consisting of triple LCD displays which formed continuous virtual workspace. One ordinary LCD was supplemented with a capacitive single-touch sensor pane and two other displays were dual-touch screens with optical sensor. In total, we compiled 5-touch tiled screen workspace. Each display was connected to the separate Apple Mac Mini. The computers were linked through the 100BaseT Ethernet. This setup is depicted in Figure 1. We chose Linux distribution Fedora 14 as the operating system for all nodes. Our prototype application was written in C/C++ language and the graphical interface was based on SDL Library³. The prototype application consists of two parts.

Daemon *Wrapper* that ran on each Mac Mini read the data from the kernel input layer and translated events to network protocol based on TUIO 2.0 specification draft⁴ which is the latest protocol for the comprehensive description of tangible interfaces and multi-touch surfaces. Complementary *Recognizer* applet was listening to these messages in order to visualize them as colored curves in a simple layout.

³ <http://www.libsdl.org/>

⁴ <http://www.tuio.org/?tuio20>

Since we are in a distributed environment, we had to take into account two factors. At first, a latency caused mainly by underlying communication subsystem; secondly the inaccuracy of a continuing stroke of the gesture that passes multiple displays (which is problem of protruding display casing).

So the recognition is based on three entries: the time lag between events and the spatial location indicating the beginning and the end of event. These data are obtained from the sensor. To ensure the correct recognition, we had to determine time and spatial thresholds that were used for strokes evaluation. Let a Δt is a limit for the time lag and Δs determines the diameter of an area in which the gesture might continue (e.g., in transition between the values of Δt and Δs we performed the informal experiment).



Figure 1. Hardware configuration of prototype implementation used for the experiment

We tested three scenarios:

1. Suppose two events recognized (no matter on which display(s)) and the temporal threshold is greater than Δt , two gestures are recognized.
2. If there are two events recognized (no matter on which display(s)) and the temporal threshold is less than Δt , one gesture is recognized.
3. If two events recognized on more than one display and the spatial threshold of the surrounding is less than Δs , one gesture is recognized.

Since the experiment was run on equally strong hardware using unloaded network, there were no external influences that might have distort our results. We were adjusting the Δt and Δs values according to the gesture visualization curves in order to ensure good recognition capability together with a reasonable degree of interaction. Discontinuity of gesture drawing signalized the values are too low. On the other hand, too large values (mainly Δs) decreased the response of the *Recognizer*, thus the interactivity.

Finally, Δt was set to 2 seconds and Δs was set to 100 pixels. For these values, all the gestures were correctly recognized and visualized according to the reality.

Figure 2 is a screenshot of the visualizing part of our *Recognizer* applet. Each display from the configuration is represented as one rectangular tile. Differently colored curves denote particular gestures. We appended the orange ovals and comments to separate different scenarios for better orientation.

Related Work

The visualization will be realized as a tiled multi-touch display wall based on SAGE (Scalable Adaptive Graphics Environment) platform. The technology was introduced in [1]. The distributed scalable architecture of SAGE allows building display walls with different sizes providing ultra resolution environments where users can visualize different applications (such as maps imagery, live visualizations or even videoconferencing windows). In the case of image visualization, there is another advantage of SAGE. The users are able to investigate details without losing the context of the whole. It is convenient for geoscientists, disaster response teams or pathologists.

The LambdaTable [4] is based on the same technology of tiled displays, but the displays are situated horizontally. Users can work with the table i.e., with specially adapted mice. LambdaTable does not support direct touch-based interface. On the other hand, there are



Figure 2. Screenshot of the *Recognizer* applet.

also case studies on local collaboration using tabletops, such as [5], combining multi-touch interface with the use of keyboard and mouse. However, this approach is mostly based on a single multi-touch device. Different approach is using top-view camera for recognition of fingers as described in [7].

In contrast to the tabletop and other local collaboration tools, where the group collaboration is native, the network-based collaborative environments are usually built on the user-to-user model. In [6] a drawing application ClearBoard where participants draw and communicate as if they were on the opposite sides of a window is presented. This solution is designed for 2D workspace. Another one-to-one collaborative environment introduced in [2] extends this model to the 3D workspace with the multi-touch support. In [3], a toolkit for deploying peer-to-peer distributed graphical user interfaces regardless used devices, operating systems or number of individual users.

Future Work

We presented several key observations that influenced the preliminary outcomes concerning the design of the group-to-group collaborative environment. We also demonstrated feasibility of the basic gesture recognition in locally distributed environment on the prototype.

Our current work is primarily focused on developing the gesture recognizer for local distributed environment based on tightly-coupled rendering clusters. In doing we rely on the knowledge gained from the experimental prototype implementation.

From the long-time perspective, we will continue with enhancing the functionality towards cooperation of mul-

iple geographically dispersed distributed multi-touch screens. This is closely bound with the developing of network protocols for efficient and fast synchronization as well (we still require the system interactivity). Finally, we will follow with a development of middleware for integration with existing applications and videoconferencing tools and developing new ones.

Acknowledgements

This project has been supported by research intents "Parallel and Distributed Systems" (MŠM 0021622419) and "Optical Network of National Research and Its New Applications" (MŠM 63873917201).

References

- [1] Renambot, L., et al. *SAGE: the Scalable Adaptive Graphics Environment*. WACE'04, Nice, France. September 2004.
- [2] Arroyo, E., et al. Distributed Multi-Touch Virtual Collaborative Environments. CTS'10, Chicago, IL, USA. May 2010.
- [3] Melchior, J., et al. A Toolkit for Peer-to-Peer Distributed User Interfaces: Concepts, Implementation, and Applications. EICS'09, Pittsburgh, PE, USA. July 2009.
- [4] Krumbholz, C., et al. Abstract Lambda Table: High Resolution Tiled Display Table for Interacting with Large Visualizations. WACE'05, Redmond, WA, USA. September 2005.
- [5] Hartmann, B., et al. *Augmenting Interactive Tables with Mice & Keyboards*. UIST'09. Victoria, BC, Canada. October 2008.
- [6] Ishii, H. and Kobayashi, M. ClearBoard: A Seamless Medium for Shared Drawing and Conversation with Eye Contact. CHI'92. Monterey, CA, USA. May 1992.
- [7] Do-Lenh, S., et al. Multi-Finger Interactions with Papers on Augmented Tabletops. TEI'09. Cambridge, UK. February 2009.

Distributed Group Collaboration in Interactive Applications

Serge Gebhardt

ETH Zurich
Chair for Information Architecture
Zurich, Switzerland
gebhardt@arch.ethz.ch

Christine Meixner

ETH Zurich
Chair for Information Architecture
Zurich, Switzerland
meixner@arch.ethz.ch

Remo Aslak Burkhard

vasp datatecture GmbH
Zurich, Switzerland
Remo.Burkhard@vasp.ch

Abstract

This paper describes approaches for near-realtime collaboration over distance in interactive applications. It presents approaches to tackling most of the encountered challenges by using our interactive risk management tool as an illustrative example. In particular it focuses on browser-based client-server network communication, concurrent object manipulations, and data synchronization.

Keywords

Collaborative computing, web-based interaction, synchronous/concurrent interaction, risk management, multi-touch collaboration, evaluation/methodology.

ACM Classification Keywords

H5.3. Information interfaces and presentation (e.g., HCI): Group and Organization Interfaces.

Introduction

This paper describes approaches for near-realtime collaboration over distance in interactive applications. As an illustrative example we will use our risk management tool, which exposes these challenges. For this we first introduce the environment.

The ETH Value Lab (Figure 1) is an attractive space with daylight and high ceilings. It is equipped with three large wall-mounted multi-touch screens, two large table-mounted multi-touch screens, three video

Copyright is held by the author/owner(s).

TEI'11, Work-in-Progress Workshop
Jan 23, 2011, Madeira, Portugal.

projectors and a video conferencing system. The concept is described in [7].

We found out that the ETH Value Lab is an ideal environment for collaborative workshops [6]. We then developed a novel software-based approach for a wide range of management tasks such as risk, strategy or project management, which leverage the capabilities of the ETH Value Lab in the context of collaborative workshops.

In order to bring collaboration a step further, we envisioned approaches to overcome social and technical challenges, and developed a tool that enables collaboration over distance.

Implementing this near-realtime distributed collaboration posed some challenges, such as browser-based client-server network communication, concurrent object manipulations at different locations, and data synchronization.

In this article we describe approaches to tackling most of these challenges, using our risk management tool as an illustrative example.

Risk Management Tool

To illustrate our technical research contribution we first introduce the application context, which is risk management.

The responsibility of enterprise risk management lies in the hands of the board management. They are responsible for identifying, evaluating, and assessing the risks, as well as deriving actions to reduce these risks. We identified three main challenges in current quantitative risk management approaches:



Figure 1. ETH Value Lab with five multi-touch displays (Source: Chair for Information Architecture, ETH Zurich).

Getting the big picture: Risk management systems become increasingly detailed and complex. Monthly risk reports easily exceed 100 pages and decision-makers quickly lose the overview. How can a software tool provide such an overview?

Risk assessment with multiple stakeholders: More and more stakeholders become involved in the risk assessment process, such as the board of management, the executive board, the auditing firm and team leaders. They all have diverging backgrounds, risk perceptions and professional experiences. How can the quality and involvement in a risk assessment meeting be increased, while assisting decision-making? Research has shown that visualization techniques are very useful for group coordination and group decision-making [5,9,10,11,12].

Creating risk evaluation reports: To comply with legal regulations companies must provide a risk

evaluation, e.g. as part of their annual report. However, there are no established best practices on how to create such risk evaluation reports.

We devised an ideal approach to overcome these three challenges [2] and developed the interactive risk management tool (Figure 2).

We introduced the application context of our research contribution, which is a distributed collaborative system. In the next section we will describe the software aspects in more details.

Approach to Interaction over distance

The risk management tool is built with ease of use in mind: users simply connect to the website and instantly run it in the browser. Alternatively, they can choose to install the software as a native application in the operating system. The installation process is nothing more than a right-click and choosing "Install".

Two modes of operation are available: an online mode and an offline one. The browser version always runs in

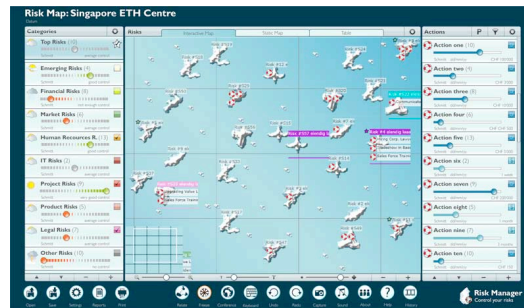

Figure 2. Risk management tool (Source: Chair for Information Architecture, ETH Zurich).

online mode, whereas in the native application users can choose between both modes.

When used in offline mode the application behaves autonomously and is completely separate from the server. This mode obviously offers no support for distributed collaboration.

When used in online mode the application registers with the server by sending the user-provided username and password. Upon successful authentication it loads the initial data from the server. Every subsequent data modification is broadcasted to all registered clients. Changes are thus synchronously sent to all remote parties at the same time and the tool is ready for distributed collaboration.

Client Application Architecture

Our tool is built up on three different parts: the CORE framework, the Business Application Framework (BAF), and on top the logics and user interface specific to a given tool.

The CORE framework implements basic functionality, such as generic support for multi-touch and drag&drop. It includes a flexible data model. The compiled output is a DLL and a test application.

The BAF imports the CORE compiled DLL and extends its functionality. For instance it has presets for the user interfaces and data models common to most planning tools. As with the CORE, the compiled output is a DLL and a test application.

The tool builds up on both frameworks by including their compiled DLLs. It extends them even further by implementing business-specific logics, user interfaces and data models on top of those already in the BAF.

This three-layered architecture allows for a flexible and customizable implementation. Other tools can build up on the same CORE and BAF frameworks, because they are designed with flexibility and extensibility in mind.

Challenges with Distributed Collaboration

Collaboration over distance inherently poses new challenges not found in standalone applications. This section focuses on two of them: (1) browser-based client-server network communication; and (2) concurrent object manipulations.

Browser-Based Client-Server Network Communication

For security reasons applications running in a web-browser are generally not allowed to open generic network sockets.

Browser applications are therefore bound to exclusively use the standard HTTP protocol. This has three added benefits: (1) easily passes through corporate firewalls, which usually block generic socket connections; (2) solves authentication, which is already defined for HTTP; and (3) solves privacy issues because HTTP can be encrypted with the industry-standard SSL encryption protocol (HTTPS protocol).

But by specification the HTTP protocol requires the web-client to open a connection to the server and request a given document. The client can also pass arguments to the query. The server replies with the requested document. In our context of distributed collaboration this implies that only the client application can open a connection to the server, never the other way around. How can data modifications then be pushed from the server to the registered clients?

Further the HTTP protocol was not designed for messages going indefinitely back and forth between

clients and server, but rather for a single request-response dialog. In our context of distributed collaboration this poses a challenge to keep connections open and active between the server and all its registered clients.

To solve these issues we implemented the *HTTP Duplex Channel* technique. It has partly been integrated into Microsoft Silverlight 4. It enables the browser application to overload the HTTP connection to the server with the illusion of a bi-directional channel, likewise to a generic socket.

The client connects to the server without requesting a document, but leaving the connection open as long as possible. When the server has data modifications to push to all its registered clients, it first queues the messages locally and sends them to the clients as soon as they become available. The client re-opens the channel to the server upon disconnection. This provides the illusion of a bi-directional channel supporting near-realtime message pushing between a HTTP server and multiple clients.

This technique is quite error-prone when implemented incorrectly. It then results in seemingly random behavior and debugging network channels is always cumbersome.

Concurrent Object Manipulations

In the context of collaboration over distance attention must be given to concurrent operations. Two users at different locations may not manipulate the same object at the same time.

Our approach introduces a token per object. When a client wants to modify an object, it requests the token for that object. If no token is assigned to it, the server

provides a token to the client and registers the association. When the client has finished modifying the object and transmitted the changes back to the server, it requests the release of the token. The server then unregisters the token from the object, hence deleting the association between client and object. The object is now free for other clients to request its token.

In case a client requests the token for an object that is already associated with a token, the server declines the requests with a "has token" message. The client must then display an error message to the user and retry the token request at a later time.

The client, in which the workshop manager is logged in, benefits from higher privileges than all the other clients. He has the power to revoke other clients' tokens and can reclaim them for himself at any time. This serves two purposes: (1) he can revoke writing privileges from misbehaving clients; and (2) he can return locked objects to all other clients. The latter reason need not be with bad intentions; it could result from network problems, or a client forgetting to confirm a dialog box.

This token-based approach does not take fairness into account. Hence resource starvation is possible if a client always requests all tokens on all objects. The tools are used in the context of distributed collaboration, as opposed to distributed sabotage; hence we do not consider this a drawback. The workshop manager always has the power to exclude a misbehaving client and thus restore fair resource allocation.

Further enhancements

The presented material is work-in-progress and we are currently expanding it further, especially regarding

support for mobile devices, synchronization of the user interface, and three-way data synchronization.

Mobile Devices

We plan to port our planning tools to a wider range of mobile devices, beyond the laptop. Some problems remain to be solved, especially concerning the execution environment: our frameworks and applications are developed in Microsoft Silverlight, which is not (yet) available for most mobile devices. Furthermore we must develop an interaction logic specific to small screens.

User Interface Synchronization

We discovered that workshop participants connected from a remote location easily lose track of data modifications done by other participants. The best approach to tackle this challenge is to synchronize the user interface across all participants.

Depending of the infrastructure, some participants may choose to open different views of the application simultaneously on different screens. How can then the user interface be synchronized? Furthermore we may need to introduce a token-based locking mechanism as detailed above.

Three-Way Data Synchronization

Currently collaboration is only possible either fully online or fully offline; a mixed mode is not supported. We plan to overcome this limitation and implement three-way data synchronization.

Then a user could participate in the workshop or download the workshop data to his laptop. While on the go, s/he could work on the data, e.g. re-assess risks or update progress. Once back online, the changes would be matched and differentially updated on the server.

Furthermore multiple users could work offline on the same data in parallel and all changes would be synchronized. How to handle conflicting changes is still an unsolved issue.

Conclusion

We presented approaches for near-realtime collaboration over distance in interactive applications. We described approaches to tackling most of the encountered challenges by using our interactive risk management tool as an illustrative example.

These approaches are stable and being used in productive software. We are currently working on the discussed enhancements to further improve collaboration over distance.

References

- [1] Åhlberg, M.: "Varieties of Concept Mapping". In Proc. 1st Intl. Conference on Concept Mapping 2004.
- [2] Burkhard, R. and Merz, T.: "A Visually Supported Interactive Risk Assessment Approach for Group Meetings". In Proc. I-KNOW 2009.
- [3] Cart, SK., Mackinlay, JD., Shneiderman, B.: "Readings in Information Visualization: Using Vision to think". Morgan Kaufmann Publishers Inc., 1999.
- [4] Chen, C.: "Mapping Scientific Frontiers: The Quest for Knowledge Visualization". Springer London, 2003.

[5] Eppler, M. and Burkhard, R.: "Visual Representations in Knowledge Management". In Journal of Knowledge Management, 11, 4 (2007), 112-122.

[6] Halatsch, J. and Kunze, A.: "Value Lab: Collaboration in Space". In Proc. 11th International Conference Information Visualization 2007 (IV'07), IEEE, Switzerland, Zurich, 376 - 381.

[7] Halatsch, J., Kunze, A., Burkhard, R. and Schmitt, G.: "ETH Value Lab - A Framework for Managing Large-Scale Urban Projects". In 7th China Urban Housing Conference, Faculty of Architecture and Urban Planning, Chongqing University, Chongqing (2008).

[8] Horn, RE.: "Visual Language: Global Communication for the 21st Century". MacroVU Press, 1998.

[9] Kaplan, RS. and Norton, DP.: "Having Trouble with Your Strategy? Then Map It". In Harvard Business Review, 2000.

[10] Kaplan, RS. and Norton, DP.: "Strategy Maps: Converting Intangible Assets into Tangible Outcomes". In Harvard Business School Press, 2004.

[11] Tergan, SO., Keller, T.: "Visualizing Knowledge and Information. An Introduction". In Knowledge and Information Visualization: Searching for Synergies. LNCS 3426, Tergan SO. and Keller T., Springer-Verlag Heidelberg, 2005.

[12] Vande Moere, A., Miesusset, KH. and Gross, M.: "Visualizing Abstract Information using Motion Properties of Data-Driven Particles". In Conference on Visualization and Data Analysis 2004.

Toward Toolkit Support for Integration of Distributed Heterogeneous Resources for Tangible Interaction

Cornelius Toole, Jr.

Center for Computation and Technology
Louisiana State University
Baton Rouge, LA 70803 USA
cornutoole@cct.lsu.edu

Brygg Ullmer

Center for Computation and Technology
Louisiana State University
Baton Rouge, LA 70803 USA
ullmer@lsu.edu

Kexi Liu

Center for Computation and Technology
Louisiana State University
Baton Rouge, LA 70803 USA
kliu@cct.lsu.edu

Rajesh Sankaran

Center for Computation and Technology
Louisiana State University
Baton Rouge, LA 70803 USA
rajesh@cct.lsu.edu

Christian Dell

Center for Computation and Technology
Louisiana State University
Baton Rouge, LA 70803 USA
cdell@cct.lsu.edu

Christopher Branton

Center for Computation and Technology
Louisiana State University
Baton Rouge, LA 70803 USA
branton@lsu.edu

Abstract

Building tangibles-based applications for distributed computing contexts compounds the complexity of realizing tangible interfaces with the complexity of distributed computing. We present preliminary work toward a toolkit that represents steps toward decoupling these concerns. This toolkit enables users to build tangible applications for a range of computational contexts that vary in the number, type and locality of tangible interaction devices with minimal changes to source code.

Keywords

Tangible user interfaces, distributed user interfaces, tangible interaction toolkits

ACM Classification Keywords

H5.2. Information interfaces and presentation: Miscellaneous.

General Terms

Design, Human Factors

Copyright is held by the author/owner(s).

TEI'11, Work-in-Progress Workshop

Jan 23, 2011, Madeira, Portugal.

Introduction

Computing applications and services we use everyday are increasingly distributed and multi-granular. Datasets are becoming more numerous, massive and spread about the world. Processing elements are scaling both up and out as with the move toward multiple core processing and the proliferation of objects with embedded processors and network connectivity. But we face significant challenges to engaging these resources through user interaction. For emerging interactive paradigms such as tangible and embedded interfaces, the challenges of tangible interface development are compounded with the complexity of integrating distributed, heterogeneous resources.

Large-scale scientific visualization is an application domain for which distributed, heterogeneous computing is becoming more commonplace. Our collaborators build applications and services for visual analysis of huge volumes of scientific data (several gigabytes to petabytes), hosted on servers across the globe. We have co-developed several tangible interaction-based applications for distributed computing contexts, one of which we overview in this paper. From these experiences we identify several distributed tangible interaction concerns:

1. The concern of integrating diverse, physical interaction devices;
2. Concerns of mapping user input to desired behavior onto objects within the domain functional core;
3. The concern of coordinating interactive elements over several types of communication channels

We present a toolkit prototype that separates these concerns. This toolkit supports development of

tangible-based applications that target a range of computing contexts within minimal code changes. This toolkit is characterized by:

- Flexibility via interaction resource proxies
- Abstract interfaces that encapsulate interactive behavior
- Network-transparent interaction device integration

Related Work

This paper builds upon related work primarily in the areas of tangible interface toolkits. Several tangible interface toolkits handle device management details and provide users with abstractions that present physical interaction devices as physical widgets or physical event generators [4, 7, 9, 12]. Several toolkits support integration of tangible input based upon computer-vision [8, 9, 11]; other toolkits support the integration of mechatronic-based tangibles [2, 4, 5, 12]. Our toolkit is agnostic to the underlying sensing technology and can support both vision and mechatronic tangibles via APIs for a class of tangible interactors [9, 13]. Virtual objects that exhibit behavior of a given modality can be bound to a given concrete interactor regardless of physical implementation.

Tangible interaction toolkits also differ in the range of computational contexts they can support. Several toolkits were designed with native support for localized interaction [4, 9]. Some toolkits employ communication mechanisms typical to ubiquitous computing systems [2, 10] in which distributed components are integrated without a priori knowledge. These interaction-programming approaches simplify the integration of many components. Other toolkits are based upon a client-server communication model, yielding higher

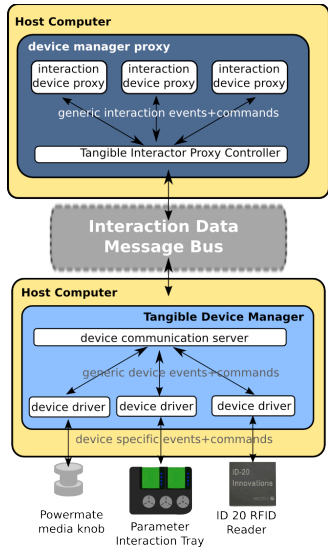

Figure 1 TUIKit Architecture: A Module Layout Diagram

performance and simple designs for simple configurations [8]. Another approach is to hide network-programming details, resulting in a programming approach that more closely resembles familiar development environments [10]. Our approach seeks to support the construction of distributed tangible applications that yield scalable performance but not in apparent system complexity.

A Tangible Interaction Toolkit Prototype

Motivated by earlier experiences in developing tangibles for distributed, heterogeneous computing we are building a toolkit, tentatively called TUIKit. We are motivated by the possibility of an interactive system architecture that allows a developer to disregard whether some component is local or remote so long as it is appropriate, available and provides acceptable performance. We also envision an architecture that gives interaction designers the option of several components that provide a given function despite diverse implementations and forms.

Fig. 1 illustrates the core components of the current TUIKit architecture. This work-in-progress toolkit is based upon several core concepts:

1. Loose coupling through composition of proxies;
2. Generic APIs for overlapping capability providers;
3. Adaptors to access heterogeneous resources;
4. And communication transparency.

Loose coupling via composition of proxy objects

In our model, developers compose interactive applications by adding proxies to an interactive context. These proxies provide a gateway for accessing one or

more resources. These resources currently include interaction devices (physical and virtual) and in the future other computational capabilities (e.g. data services, application domain objects and services). These proxies can be bound dynamically at runtime. For instance a developer may add to her interface composition a proxy for a rotary input that may be physically connected to her host computer and at another time wish integrate a dial connected to some other host via network.

Generic APIs for Interactive Resources

Our toolkit provides APIs that abstract implementation specific details for a given physical interaction modality. An interactive proxy provides a concrete resource by implementing that provider's interface. This approach builds on the approach of several tangible programming toolkits to provide abstract APIs for multiple tangible interaction device implementations [4, 5, 7, 10].

Adaptors for Heterogeneous Resources

While interaction resource proxies provide a generic programming interface, adaptors translate between the abstract interface for a class of interactive resource providers and a particular interaction resource implementation. It is through these adaptors we intend to expose features unique to a particular resource provider.

Communication Channel Transparency

Proxies are bound to the concrete resources they represent over an interaction message bus that provides a generic interface for several communication models (e.g. client-server, publish-subscribe, multicast, peer-to-peer) over several communication channels (network sockets, Unix pipes for inter-process

communication, shared memory for intra-process communication). Using this approach resources for interaction are integrated in a network-transparent manner. Currently, TUIKit only uses client-server and publish-subscribe communication models, but we will explore other models in the future.



Figure 2 A. User uses physical dials to control a remote-generated visualization of black hole simulation data. B. Gulf of Mexico Oil Spill Data Visualization User Interaction can be driven by casier tangibles [15] that are mediated both by the MS Surface and Apple iPad.

Use Cases

Here we describe two uses of TUIKit for development of distributed tangibles-based applications.

Tangible for Large Scale Interactive Visualization

Our collaborators are developing an environment for real-time, interactive large-scale data visualization applications. Many of the use-cases supported by this environment involve the use of remote distributed resources for data, and graphics rendering. Work sessions supported by these systems may involve multiple users at multiple locales engaging several visualization services instances. In earlier efforts to support remote interactive visualization, they found tangible interaction to have favorable properties, and

so we were asked to design tangibles to drive user interaction. The tangibles we provided were based on the parameter interaction tray tangible, in which abstract parameters of visualization can be bound to individual physical controls [15, 16]. TUIKit was used to integrate remote user interaction, (Fig. 2a). An early demonstration of this was a winning entry in an international competition on innovative uses of large-scale computing resources in which a collaborator uses using tangibles from Shanghai, China to control giga-scale data visualization on resources in the southeastern United States [6].

Surface Oil Spill Data Visualization Tangibles

The April 2010 BP Oil Spill has sparked much research and public outreach activity. One effort in which we have been involved concerned the development of a Microsoft Surface application for visualizing geospatial data related to the BP Oil Spill (Fig 2b). TUIKit was used to explore the integration of tangible interaction techniques within the tabletop environment. Users could engage the application via a Surface-mediated tangible that supports physically constrained touch-based interaction as well as the manipulation of tagged objects to simulate physical controls. This same artifact can be mediated by an Apple iPad to provide similar functionality. We call these objects, casier tangibles, which are discussed in depth by Ullmer et al [15].

Toolkit Implementation Status

TUIKit consists of device drivers and plug-ins, a device manager, an interaction message bus and class library with bindings for python, Java and C#. TUIKit currently supports several mechanical-electronic (mechatronic) interaction devices including dials based upon several

types of sensors and an RFID reader, which were all developed using the Blades and Tiles modular interaction hardware toolkit [14]. This toolkit also supports commercially available physical interaction devices including the Griffin Powermate media control knob, and RFID modules by ID Innovations and Olimex. For the Surface Oil Spill application, we wrote an adapter to transform OSC messages generated by the touchOSC iphone/iPad application. We are currently preparing TUIKit for release as an open source library.

```
class vizController:
    ...
    //Zoom camera when dial is turned
    def zoomOnDialEvent(self, event):
        delta = event.value - self.last_val
        self.zoom(delta)

def main():
    ixerCtrl = interactorController()
    dial1 = ixerCtrl.getInteractor('rotary1')
    vizCtrl = vizController()
    dial1.addListener(TUIKit.ROTATEDIAL,
    vizCtrl.zoomOnDialEvent)
    ixerCtrl.add(dial1)
    ixerCtrl.start()
```

Figure 2 Code Snippet: Using TUIKit to control visualization

Discussion

The code snippet in Fig. 3 shows how one might integrate a rotary input to control the zoom camera function within a visualization application. Early versions of the TUIKit class library were used in two semesters of an introductory interface design and technology course. This library was used for integrating

physical controls and tangibles with existing graphical user interfaces, and so there was a desire to integrate into programming environments familiar to the students. At the time of this writing, TUIKit has been used to integrate tangible input into applications built with Java SWT, Java Swing, Processing/Java, OpenGL/C++, and C#/Windows Presentation Frameworks (WPF).

TUIKit builds upon the innovations of many prior and parallel efforts for building applications that employ post-WIMP interaction techniques. Ultimately, we wish to realize system architectures capable of scaling in the number of users, devices and locales. In the future we will perform performance tests to evaluate how scalable TUIKit is. Our goal is to achieve responsiveness of at least 10 events per second per device (~100ms per device-event) and low jitter for interaction over high latency network connections. We think this is possible because the interaction message bus is based on communication infrastructure designed to handle 1000s of message per second [1]. The challenge will be providing developers with abstractions that allow them to more easily design and manage such large systems.

Acknowledgements

This work has been supported in part by NSF MRI-0521559, IIS-0856065, EPSCoR RII-0704191, and La. BoR LEQSF (2008-09)-TOO-LIGO Outreach. Thanks also to Alex Reeser, Landon Rogge, Andrei Hutanu and Jinghua Ge.

References

- [1] OMQ – Zero Message Queue Protocol
<http://zeromq.org/>
- [2] Ballagas, R., Ringel, M. Stone, M. and Borchers, J. iStuff: A Physical User Interface Toolkit For Ubiquitous Computing Environments. *In Proc. of CHI'03*, ACM Press (2003), 537-544.
- [3] Couture, N., Rivi`ere, G. and Reuter, P. GeoTUI: A Tangible User Interface For Geoscience. *In Proc. of TEI '08*, ACM Press (2008), 89-96.
- [4] Greenberg, S. and Fitchett, C. Phidgets: Easy Development Of Physical Interfaces Through Physical Widgets. *In Proc. UIST'01*, ACM Press (2001), 209-218.
- [5] Holleis, P. Programming Physical Prototypes. In Proc. of the 1st International Workshop on Design and Integration Principles for Smart Objects, 2007.
- [6] Hutanu, A., Schnetter, E., Bengler, W., Bentivegna, E., Clary, A., Diener, P., Ge, J., Allen, G and others. Large Scale Problem Solving Using Automatic Code Generation and Distributed Visualization. *Scalable Computing: Practice and Experience* 11, 2 (June 2010), 205-220.
- [7] Johanson, B. and Fox, A. Extending Tuplespaces for Coordination in Interactive Workspaces. *Journal of Systems and Software* 69, 3 (2004), 243-266.
- [8] Kaltenbrunner, M. and Bencina, R. ReactIVision: A Computer-vision Framework for Table-based Tangible Interaction. *In Proc. of TEI'07*, ACM Press (2007), 69-74.
- [9] Klemmer, S. and Landay, J. Toolkit Support for Integrating Physical and Digital Interactions. *Human-Computer Interaction*, 24, 3 (2009), 315-366.
- [10] Kobayashi, N., Tokunaga, E., Kimura, H., Hirakawa, Y., Ayabe, M. and Nakajima, T. An Input Widget Framework For Multi-Modal And Multi-Device Environments. *In Proc. of the Third IEEE Workshop on Software Technologies for Future Embedded and Ubiquitous Systems*, IEEE Computer Society (2005), 63-70.
- [11] Kumpf, M. Trackmate: Large-Scale Accessibility Of Tangible User Interfaces. Master's thesis, MIT, 2009.
- [12] Marquardt, N. and Greenberg, S. Distributed Physical Interfaces With Shared Phidgets. *In Proc. of TEI '07*, ACM Press (2007), 13-20.
- [13] Myers, B. A New Model For Handling Input. *ACM Trans. Inf. Syst.* 8, 3 (1990), 289-320.
- [14] Sankaran, R. Ullmer, B., Ramanujam, J., Kallakuri, K., Jandhyala, S., Toole, C., and Laan, C. Decoupling Interaction Hardware Design Using Libraries Of Reusable Electronics. *In Proc. of TEI'09*, ACM Press (2009), 331-337.
- [15] Ullmer, B., Dell, C., Gill, C., Toole, C., Wiley, H-C., Dever, Z., Rogge, L., Bradford, R., Riviere, G., Sankaran, R., Liu, K., Freeman, C., Wallace, A., DeLatin, M., Washington, C., Reeser, A., Branton, C., and Parker, R. Casier: Structures for Composing Tangibles and Complementary Interactors for Use Across Diverse Systems. To appear in Proc. of TEI'11, 2011.
- [16] Ullmer, B., R. Sankaran, S. Jandhyala, B. Tregre, C. Toole, K. Kallakuri, C. Laan, M. Hess, F. Harhad, and U. Wiggins. Tangible Menus And Interaction Trays: Core Tangibles For Common Physical/Digital Activities. In Proc. of TEI'08, pages 209-212, 2008

Designer driven interaction toolkits

Walter A. Aprile

IO-Studiolab
Industrial Design Engineering
Delft University of Technology
Landbergstraat 15
2628CE Delft
Netherlands
w.a.aprile@tudelft.nl

Aadjan van der Helm

IO-Studiolab
Industrial Design Engineering
Delft University of Technology
Landbergstraat 15
2628CE Delft
Netherlands
a.j.c.vanderhelm@tudelft.nl

Copyright is held by the author/owner(s).
TEI'11, Work-in-Progress Workshop
Jan 23, 2011, Madeira, Portugal.

Abstract

Most interaction toolkits, historically, have been designed by technologists for designers. In this workshop paper we explore how designers could design such a toolkit for themselves, following their own methods and focusing on their disciplinary concerns.

Keywords

Interaction, design, tangible interaction, user-driven design, hacking, prototyping, Arduino, Max/MSP

ACM Classification Keywords

D.2.2 Design Tools and Techniques: *Evolutionary prototyping, User Interfaces*

General Terms

Workshop paper, Work in progress

Introduction

Interaction toolkits are software and hardware toolkits that enable designer to prototype and develop interactive systems. Notable examples include Arduino[8], a C-based microcontroller development system, Processing [11] and [12], a Java derived development environment focused on interactive graphics and Max/MSP, a commercial visual programming language for multimedia with over twenty years of evolution behind itself. Like Arduino, Processing and MAX, most interaction toolkits have

been designed and developed either by technologists working in close collaboration with designers, or by researchers/practitioners with a background that spans computers and design. Moreover, the developers of these toolkits are frequently engaged in designer education. We wanted to experiment with an interaction toolkit for designers and *by* designers. Design MSc students with no particular expertise in the field have been let loose into what was, for them, unexplored land. The results are certainly different from technology (and technologist) driven interaction toolkits.

Context

The course "Interactive Technology Design" introduces design students to interactive prototyping and its tools. Sketches and prototypes are used initially for inspiration and, towards the end of the course, for involving users. The prototypes are exhibited at the end of the course for a combination of show and user testing under fairly realistic condition.

Two student teams were given as a brief "*explore, on the basis of your experience with interactive sketching tools, a designer-driven design for an interactive sketching tool*". Students were given a minimal bibliography including [4], , roBlocks [13] , [7] (shared Phidgets), iStuff [10] and [1] on sketching user experiences. It was suggested to think of toolkits in the context of practices [14] which, in this case, were the design students own practices.

Students were asked to proceed through five iteration steps, each one of which offered the chance to broaden the field of inquiry. The steps took up progressively more time, as the students committed to certain

elements of their design and decided which directions were most promising. Moreover the students were also encouraged to explore toolkits that do not particularly focus on interaction, like the ones made by Bosch, Lego, Fischer Technik. Students were encouraged to think of two intentionally vague use cases: designing a lamp and designing an alarm clock. The students were also introduced in detail to the Arduino system and to Max/MSP.

Process

The context of this work is the field of Design, not HCI or Computer Science. Rigor in Design takes different forms than in science and engineering: fundamental concerns differ. For example, Turing-completeness would be an important concern from a computer science point of view, while from a design point of view it could just be a desirable feature. Again, from an HCI perspective, extensive user testing and design validation is key, while design projects frequently lack resources or –to be honest- focus and interest towards this type of activities.

On the other hand, Design is always very concerned about the appearance of its manifestations. Choices of palette and typography, material feel and texture, and more generally "form" get a great deal of attention. Such choices, speaking again in a very general way, can hardly be said to be a key concern of practitioners of CS or HCI.

Moreover, and we are aware that this is a very broad generalization, Design practitioners tend to focus on complete systems (as opposed to specific technologies or interface elements or techniques). Complete systems of the scale we develop tend to be very difficult to

study comparatively. Such systems tend to be evaluated on the merits of their aesthetic consistence, their innovativeness for the design field and their conceptual strength.

The expression “designerly way of knowing” is due to Nigel Cross [2] and [3], and it is sustained by the assumption that there is a third way of knowing, different from the way of the natural sciences and the way of the humanities. The process followed in the design of Atreyu and Sketchonary has been thoroughly designerly, in that it has aimed to broaden the field of inquiry to human, cultural and technological issues through aggressive iteration, converging finally on designs that cannot be justified scientifically but can be defended in the design domain.

Results

We describe here the two systems we have designed. They stand in almost direct contrast one to one, as Atreyu is a purely physical TUI without any element of GUI, while Sketchonary uses video-tracking and retro-projection to augment physical tokens with computational behaviors.

Atreyu

The Atreyu system appears as a grid of equilateral triangles. The individual triangle can be connected on all sides to its neighbors. Each triangle forms a node of an improvised network that transfers power and data. Triangles can host IO modules (white) or act as simple passive bridges (black). One special red triangle injects power in the network and stores the current configuration.

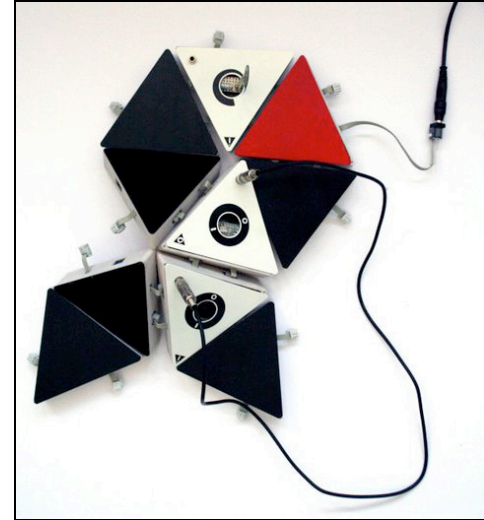

Figure 1: A small Atreyu network. The black wire temporarily connects two IO modules to establish a relationship between them. Black modules are passive.

Relationships between inputs and outputs are established by temporarily connecting two modules with a patch cable inserted into a socket on the top face of the triangle. Each black triangle contains an Arduino Pro Mini, running the I2C protocol for connectivity. The Arduino is mounted on a custom PCB contained in a custom, 3D printed case.

In the current design, the Atreyu system is limited to simple proportional relationships between triangles: turn a knob more, and the light goes up, shake harder the vibration sensor and an LED blinks faster. Although

the design specifies also processing and control modules, such as timers and adders, these modules have not been realized during the course.

Difficulties were encountered at the physical level. In particular, choosing a reliable, cheap and fast connector system proved very challenging. The chosen system, due to its ease of assembly and low price was the RJ14 4-wire telephony jack.

Atreyu shares with [9] on Siftables the interest for “[exploring] how sensor network technologies might be combined with features from the GUI and TUI in order to further increase the directness of a user’s interaction with digital information or media”. In the Siftables system, though, the individual interaction element is a rather powerful computer with advanced communication and computation capabilities, while in Atreyu the basic triangle is a rather simple object. Additionally there is a strong difference in purpose: Siftable objects stand for (or are?) information objects (photographs are given as examples) to be sorted and organized, while Atreyu objects are computational network and sensor objects for exploring interaction.

A design experience similar to Atreyu, although on a very different physical scale, is Tanaka and Kaito’s I/O-CRATE, box-shaped modular units featuring embedded microprocessors, sensors, actuators and batteries. I/O-CRATES are modular, stackable and built out of beer crates for solidity. Their purpose is to build public interactive experiences for social locations or events. The programming language shown in [15] is also limited to simple action-reaction patterns, where something happens when a sensor reading satisfies certain instantaneous conditions.

While we can safely say that Atreyu fell short of the brief –it will take a lot of conceptual and technology work to make it go beyond simple input-output proportionality- it points in a direction that gives us hope for the future from a design perspective.

Positive user feedback during limited testing with designers and non-designers at the course final exhibition allows us to think that further work on this – or a similar - system could be justified.

Sketchonary

Sketchonary is a tabletop interface that enables multiuser sketching and augments it with a layer of information, real time rendering of input/output interaction. Sketchonary can compile sketches to Arduino code and upload them immediately to a board.

Sketchonary shares with Fritzing [5] a strong focus on designers as main users who are not necessarily familiar with engineering notation and thinking. The declared objective of Sketchonary is to enable the exploration of ideas and reducing slowdowns due to lack of knowledge by the designer. The system follows Buxton’s definition of sketching as questioning, exploring and suggesting what could be, rather than refining what should be [1]. For this reason, it was decided that the user should remain at a high level of abstraction and not engage with relatively low-level tools (for example, a C source code editor). In this vein, Sketchonary focuses on playful interaction without error messages but with happy accidents and multiuser interaction.

The interface of Sketchonary consists of a table surface where electronic components, drawing materials and

fiducials can be stored. The table surface contains a back-projected sketching surface where the fiducials can be placed.

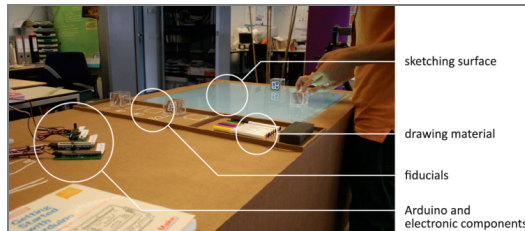

Figure 2: the Sketchonary table

Fiducial symbols applied on transparent tiles are used for most of the interaction. The set of Input fiducials comprises a manipulator box, and four input tiles; horizontal movement, vertical movement, proximity, rotation. A Timer fiducial contains the typical functions of a wake-up alarm. The output is currently limited to an RGB LED that can be controlled along five dimensions, namely RGB balance, brightness and blinking frequency.

Sketchonary can be either in Dictionary mode, where each fiducial triggers the appearance of contextually relevant on-screen documentation, or in Sketching mode, where the user defines interactive behaviors. The Mode fiducial toggles the interface between Sketching mode and Dictionary mode. Users are encouraged to sketch on the screen with whiteboard markers and place fiducials representing input and output on their sketch.

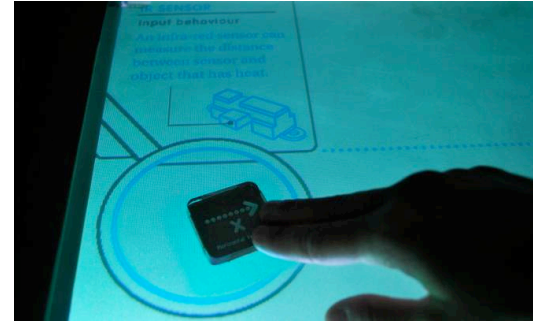

Figure 3: detail of Sketchonary in Dictionary mode.

Once the fiducials are on the screen, projected attachment points on their sides allow the user to visually snap them together and decide what input controls what output. To simulate input variation on screen, a special manipulator box is used.

Landay's pioneering work [6] is an influence on Sketchonary, mostly through its insistence on rough improvisational sketching as an early phase of design, although it remains to be said that Landay's tool, and its commercial successor SketchFlow, concentrate on GUI design while the proposed use cases for the projects we discuss in this paper are more in the physical domain.

Conclusion

Conclusions, for works in progress, are inescapably provisional. Both the Atreyu and Sketchonary team chose to forgo generality and narrowly focus on one use case. The interfaces have been developed to a level that allows limited and informal user testing, enough to decide how to take the projects on.

From an engineering and scientific point of view it can be argued that, due to the design teams near total lack of previous experience with interactive prototyping or electronics, the designers retreated on the safer ground of detailing, materials and texture, while developing insufficiently the computational framework and, more in general, being a bit vague with the technology.

From a design point of view, many things were “gotten right”: aesthetic consistency, a fluid interaction style, style, desirability and some irony in the presentation of the projects are something to be encouraged.

The question of how to apply user-driven design when the users are designers is still open. We want to take this work further, either by developing Sketchonary and Atreyu or by giving the same brief to more students.

Acknowledgements

We thank the following students for their significant contribution to this work: Ainhoa Ostolaza, Thijs Waardenburg, Palma Fontana, Alice Mela, Robert Paauwe, Simone Rebaudengo, Karla Rosales, Enrica Masi, Myeongsoo Shin and Kim Sohyun.

Bibliography

- [1] Buxton, B. (2007) *Sketching user experiences: getting the design right and the right design*. San Francisco, CA, Morgan Kaufmann.
- [2] Cross, N. (1982) Designerly ways of knowing. *Design studies*; 3(4), pp. 221-227.
- [3] Cross, N. (2007) Forty years of design research. *Design studies*; 28(1), pp. 1-4.
- [4] Greenberg, S. (2007) Toolkits and interface creativity. *Multimedia Tools and Applications*; 32(2), pp. 139-159.

- [5] Knörig, A., Wettach, R. and Cohen, J. (2009) Fritzing: a tool for advancing electronic prototyping for designers.
- [6] Landay, J. A. (1996) SILK: sketching interfaces like crazy. Conference companion on Human factors in computing systems: common ground. Vancouver, British Columbia, Canada, ACM.
- [7] Marquardt, N., Greenberg, S. (2007) Shared Phidgets: A Toolkit for Rapidly Prototyping Distributed Physical User Interfaces. *Proceedings of Tangible and Embedded Interaction (TEI)*, pp. 13-20.
- [8] Mellis, D. A., Banzi, M., Cuartielles, D. and Igoe, T. (2007) Arduino: An Open Electronics Prototyping Platform. *CHI 2007*, San José, USA, April 28 - May 3, 2007.
- [9] Merrill, D., Kalanithi, J. and Maes, P. (2007) Siftables: towards sensor network user interfaces. Proceedings of the 1st international conference on Tangible and embedded interaction. Baton Rouge, Louisiana, ACM.
- [10] Rafael, B., Meredith, R., Maureen, S. and Jan, B. (2003) iStuff: a physical user interface toolkit for ubiquitous computing environments. Proceedings of the SIGCHI conference on Human factors in computing systems. Ft. Lauderdale, Florida, USA, ACM.
- [11] Reas, C., Fry, B. (2003) Processing: a learning environment for creating interactive Web graphics.
- [12] Reas, C., Fry, B. (2007) *Processing: a programming handbook for visual designers and artists*, The MIT Press.
- [13] Schweikardt, E., Gross, M. D. (2008) The robot is the program: interacting with roBlocks. TEI 2008: Second International Conference on Tangible and Embedded Interaction. Bonn, Germany, ACM; pp. 167-168.
- [14] Shove, E., Watson, M., Hand, M. and Ingram, J. (2007) *The Design of Everyday Life*. Oxford, Berg.
- [15] Tanaka, H., Kaito, S. (2007) Universal modular kit for temporal interactive place in public spaces.

Tangibles attached to mobile phones? Exploring Mobile ActDresses

Mattias Jacobsson

Mobile Life Centre at SICS
Box 1263
SE-164 29 Kista, Sweden
majac@sics.se

Ylva Fernaeus

Mobile Life Centre at SICS
Box 1263
SE-164 29 Kista Sweden
ylva@sics.se

Abstract

Mobile ActDresses is a design concept where existing practices of accessorizing, customization and manipulation of a physical mobile device is coupled with the behaviour of its software. Here we investigate potential solutions for deploying the concept using available technology. Importantly, although the design concept as such may appear straightforward, a remaining question is how this concretely could be implemented for a realistic use case to take form.

Keywords

Mobile Phone Interaction, Tangible Interaction

Introduction

We are exploring the potentials of using a metaphor of physical clothing, accessorizing and labelling as an alternative mode of controlling mobile interactive systems. A general motivation for this approach is that people already do personalise their digital devices by various physical means. Mobile phone handsets are personalised by placing stickers on them, people buy or make their own customized cases, and they attach mascots and decorative charms (Katz and Sugiyama 2006). Another motivation concerns the use of personalised digital themes and the growing amateur practices of making small and personal mobile

Copyright is held by the author/owner(s).
TEI'11, Work-in-Progress Workshop
Jan 23, 2011, Madeira, Portugal.



Figure 1. Common practices of customizing the physical surface of mobile phones (top), as well as the appearance of its digital content (bottom).

applications. The mobile phone as such is thus not merely a tangible interactive device but also an object for personal expression. The project thereby takes advantage of well-established practices of on the one end physical personalization of mobile devices such as shells and accessories, and on the other end stitches it together with software applications, games, media or complete themes (see Figure 1).

Here we present four interaction scenarios, an overview of the design space and two simple demonstrators. We end by outlining a series of design challenges yet to be addressed in future explorations.

Background and Related Work

ActDresses as a design concept could be summarized as controlling or predicting the behavior of interactive devices by attaching visible physical items to their outer surface (Fernaesus and Jacobsson 2009; Jacobsson, Fernaeus et al. 2010). These items could take the forms of text labels, pictures, or three-dimensional objects traced using detection over distance (e.g. RFID, NFC, Bluetooth, IR, sound, vision-based technology) or direct contact ID technology (e.g. iButtons, USB, vibration, and resistors). The design space also ranges conceptually from single on/off mode switchers to more complex configurations with combinations of such active labels and accessories.

Previous experiments on this theme have concerned control of robotic systems, grounded in empirical studies of user interaction with commercial products (e.g. Jacobsson 2009; Sung, Grinter et al. 2009). Another motivation concerns how clothes are worn by people to serve a range of communicative functions, indicating e.g. appropriate behaviours, group

belongings, and expected interactions [2]. Similarly, physical accessories attached to a device could be used as a resource to indicate what mode the device is currently in, and what behaviours and interactions that could be expected. Our goal with the current exploration is to broaden this work to explore how the approach could be extended to handheld devices.

Interaction Scenarios

In the design concept explored here, people are able to attach physical accessories to their mobile phone handset and by doing that also change its digital functionality or appearance in some way. To make this very general design concept easier to make sense of, we here provide four short scenarios of imagined use cases.

Little black velvet

S rarely takes any step without her mobile phone, which she everyday customises physically as well as digitally to match her own clothes of the day. Thereby the phone itself works as a fashion item that she likes to match with the dresses, shoes and other accessories she wears during the day. For each of her favourite outfits, she also has a favourite cover for her phone – sometimes in the same pattern as her dress, sometimes in the same colour as her shoes. Some of her outfits also comes with a particular music playlist and a graphic theme on her phone, e.g. one made for sunny summer outfits and one that suits better when it is dark and rainy.

The company shell

Just before entering her office E attaches the company shell to her mobile phone handset, which make the phone work both to let her into the building, as well as

a company identity marker and label on her phone. The phone is now set into a mode that switches her contact list so that it automatically loads her work contacts as her primary address book in the phone. While the shell is on, also all charges on the phone get placed on the company rather than on her personal phone bill. When leaving the office she immediately takes the shell off her phone, which then replaces her office applications with her favourite spare time applications on the front screen.

The hiking costume

J has bought a particular hiking costume for his phone, which has the primary function making it water resistant as soon as it is slid on. This costume make the phone slightly bulkier than without, and is nothing he would have on otherwise, where he prefers to have the smaller and more urban metallic designed cover. J has noted that he tend to make use of different functions of his phone when he is out hiking, and has therefore personalised the phone so that when this hiking shell is on, it automatically switches to provide the features of most important to him: in his case a map and compass application, loud speaking phone mode, and a collection of audio books that he likes to listen to when outdoors.

Personal Pearls

For every year they have been married, P has given his wife a small piece of jewellery, loaded with a little game that he has created for her mobile phone. On her phone B now has four such pearls, each representing a year they have been married and a personal interactive application. The applications are very simple in kind, but made by P to illustrate something about how he feels. When B changes to a new phone, she always

takes the jewellery too, so that the games are always with her to play with.

Technical Explorations

Here we elaborate on different strategies for implementing and deploying the scenarios outlines above based on existing standards on mobile phones on the market today.

There are many forms of wireless technologies available for mobile phone handsets, and that potentially could be used to identify physical objects. However, wireless protocols such as Bluetooth and WiFi requires active transmitters and also have relatively long range of communication, features that oppose the outset of having signs in the immediate physical context of the device that they control. Infra Red (IR) is another available technology with similar properties, but one that currently is being phased out. Using a camera together with e.g. barcodes requires more

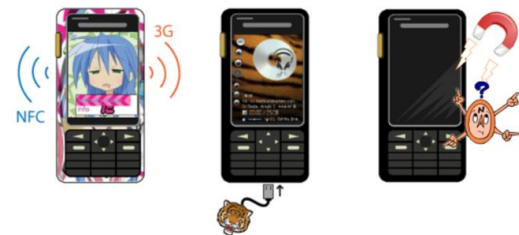

Figure 1. Left: NFC detects whether tagged shell is near, identifies it and sends the id to a server, which returns software to handheld. Middle: Charm is attached to the USB-slot, and software is loaded directly from it. Right: Magnet confuses the in-built compass sensor, and updates the software according to positioning on the shell.



Figure 2. Exploration using MID-device and USB-hub with jewellery (left) to change the visual appearance in software (right).



Figure 3. Mobile phone prototype using magnets on shells to control themes and other content.

explicit reading and is a poor match to the scenarios in the sense that it conflicts with the immediate physical context requirement by obscuring the camera. Also sound would be interesting in the sense that microphones are perhaps the most widely available technology, but is likely to require both active (or activated) transmitter and a fairly sophisticated detection service.

As with the wireless protocols, there is a range of possible solutions for using wired or direct contact connections for realizing the basic concept that we explore here. Examples, include experimental solutions such as Pin & play, iButtons, conductive stickers, resistors, or even the built in memory cards as variants for extending mobile devices beyond their ordinary functionality, even though neither of these are available on existing mobile phones.

Although new phones are getting equipped with mini-USB ports we have yet to see one with a standard port and hosting capabilities. In the explorative prototype in Figure 2 we use a MID-device, which is slightly bigger than a mobile phone but still smaller than a NetBook. In this prototype different ActDresses such as a tiger trinket and other accessories are attached to the device via a small USB-hub triggering a change of the visual theme of the device.

In another of concept demo (Figure 3), we present a solution based on physical shells equipped with small but strong Neodym (NdFeB) magnets positioned at different locations. The absolute distance between the magnet and the magnetometer in the phone is sensed, and can be used to trigger events in software. In this case a simple service program was developed that

changes the theme on a mobile Android phone according to the style of the shell. To extend this demo and to illustrate the many possible actions that could be triggered, it has been made to not only change its visual theme but also twitter its change online.

A wireless method that could be appropriate in this case is NFC, which enables the exchange of data between devices up to a 10-centimetre distance. This would work similarly to the well explored use case where the phone is used for reading passive NFC tags (e.g. for reading smart poster labels [4]). A central drawback is that in this case the reading must be constantly active on the device.

Future Design Challenges

As a guide for directing ourselves towards the design concept from a perspective of user experience, we here focus on the different ways that physical interactive artefacts may work as resources for human action and experience, e.g. for physical manipulation, for perception and sensory experience, contextually oriented action, and digitally mediated action (Fernaesus, Tholander et al. 2008).

Physical manipulations

The scenarios that we explore here aim to take advantage of the qualities of physical forms of manipulation, observed in existing practices of physical decoration of mobile phone handsets, as well as in general physical affordances. Physicality as such also brings along a range of limitations and design challenges. These include the challenges involved in finding robust technical solutions for novel physical interfaces, but also issues such as how tangible artefacts may get lost, damaged or stolen.

Apart from offline physical manipulations, this includes e.g. the importance of physical nearness when using NFC, and how a wired connection may be physically manipulated. The case of USB implies that physical 'sockets' restricts positioning of tags whereas the wireless solution can be designed to be both free and 'socketed'. However, as USB connection is not meant for permanent coupling, it may easily fall out in ordinary mobile phone usage situation.

Perception and sensory experience

An important part of the design concept concerns personal, bodily and emotional engagement, e.g. how the ActDresses feels like to hold, touch, to look at and to listen to. The physical items, as well as the digital functions that they trigger, may in many ways shape how these are made sense of. A physical 'contract' in the form of a physical wire would for instance give a subtle 'enabled/disabled' tell whereas a free tag enters or leaves an invisible frictionless space. This fact privileges direct contact methods.

Contextually oriented actions

The design concept needs to take into account actions that are not directed towards the system per se, but where users make use of the technology for communicative, social, or contextually oriented purposes. ActDresses is very much concerned with such practices, aiming to work for instance to extend the social space of interacting with a system, for getting attention by others, or as indicators of the current state of the activity. However a challenge that this brings along is the aspects of readability if combining items that are loaded with digital meaning, with those that are not.

The social dimension present in existing practices, indicating that an accessory attached to a mobile device is always a fashion statement, impossible to interpret as fully detached from its social context. Thus an important challenge is to leave the physical designs possible to adapt to individuals personal tastes, styles and cultural interests. Further, as always with physical technology come aspects of manufacturing processes, sustainability and energy management, e.g. that all mobile devices require the technology to be power efficient. This was an issue addressed in both of our concept demos, but may become an obstacle if using e.g. NFC.

Digitally mediated actions

We also need to consider how the actDresses coexists with the various forms of media or applications made accessible through the device, how they are captured, generated, communicated, controlled and manipulated. Depending on the implementation, mobile actDresses may for instance provide richer forms for accessing online, recorded and interactive media, or for digitally mediated social communication.

For instance does the solution of using the inbuilt compass sensor together with strong magnets naturally hinder and completely disturb the ordinary uses of the compass sensor. Also, no matter mode of interaction, sensing technology and physical connectivity, central design choices concern the exact design of how and what digital actions that these trigger.

Conclusions and Future work

Here we have primarily explored the technical aspects, whereas future work it have to bring focus on aspects such as aesthetics, branding and the social signalling function of the items.

We have presented two simple proof of concept demonstrators. However, neither of the prototypes shows an ideal solution for realistic deployment of our design concept and scenarios, which should use sensors designed for this or at least similar purposes. Yet they do show how existing technology can be altered for new purposes, and also provides a testbed for future user studies and design experiments that will hopefully guide us towards a better understanding of new modes for interaction with tangible objects.

In our future work we would like to test conceptual and working prototypes, as well as commercial deployments of the concept, in the wild. However, in our explorations we have not yet come to a sufficiently working solution, instead a number of intriguing challenges for future explorations have been identified.

The aspect that we would like to focus on in the work in progress workshop is how this exploration illustrates the common 'dead end' that is sometimes reached when a concept, although simplistic at first sight and well grounded in existing research, is faced with the details of actual implementation.

References

- [1] Fernaeus, Y. and Jacobsson, M. (2009). Comics, Robots, Fashion and Programming: outlining the concept of actDresses. TEI'09, Cambridge, UK, ACM.
- [2] Fernaeus, Y., Tholander, J., et al. (2008). "Beyond representations: Towards an action-centric perspective on tangible interaction." *International Journal of Arts and Technology* 1(3/4): 249-267.
- [3] Jacobsson, M. (2009). Play, Belief and Stories about Robots: A Case Study of a Pleo Blogging Community Ro-Man, IEEE.
- [4] Jacobsson, M., Fernaeus, Y., et al. (2010). The Look, the Feel and the Action: Making Sets of ActDresses for Robotic Movement DIS'10.
- [5] Katz, J. E. and Sugiyama, S. (2006). "Mobile phones as fashion statements: evidence from student surveys in the US and Japan." *New Media Society* 8(2): 321-337.
- [6] Ljungstrand, P., Redström, J., et al. (2000). WebStickers: using physical tokens to access, manage and share bookmarks to the Web. DARE, ACM
- [7] Sung, J., Grinter, R. E., et al. (2009). "Pimp My Roomba": designing for personalization. CHI'09. Boston, MA, USA, ACM: 193-196.
- [8] Ullmer, B., Ishii, H., et al. (1998). mediaBlocks: physical containers, transports, and controls for online media. *Computer graphics and interactive techniques*, ACM

Touchless Multipoint-Interaction on Large Planar Surfaces

Dionysios Marinos

University of Applied Sciences
Düsseldorf
Josef-Gockeln Str. 9
D-40474 Düsseldorf, Germany

Patrick Pogscheba

University of Applied Sciences
Düsseldorf
Josef-Gockeln Str. 9
D-40474 Düsseldorf, Germany

Björn Wöldecke

University of Applied Sciences
Düsseldorf
Josef-Gockeln Str. 9
D-40474 Düsseldorf, Germany

Chris Geiger

University of Applied Sciences
Düsseldorf
Josef-Gockeln Str. 9
D-40474 Düsseldorf, Germany
geiger@fh-duesseldorf.de

Tobias Schwirten

Lang AG, Lindlar
Schlosserstr. 8
D-51789 Lindlar, Germany
schwirten@lang-ag.com

Abstract

This paper presents a sensor device dedicated to detect multipoint-interaction on or in front of very large planar surfaces. We briefly present two application scenarios taken from the area of design review presentations of mechatronic systems and musical interfaces to illustrate the flexible applicability of our sensor device.

Keywords

Touchless multipoint-interaction, time of flight sensor

ACM Classification Keywords

H5.m. Information interfaces and presentation (e.g., HCI): Miscellaneous.

General Terms

Human Factors, Design

Introduction

In recent years natural interaction techniques on large surfaces evolved into a standard feature in many presentation scenarios including professionally designed exhibitions. Technical-oriented fair exhibits today often use multitouch technology as interactive eye-catcher and many media agencies specialized in creating suitable multimedia content for their clients. However, most available solutions that provide the necessary

Copyright is held by the author/owner(s).

TEI'11, Work-in-Progress Workshop

Jan 23, 2011, Madeira, Portugal.

robustness for interactive fair exhibits are tabletop systems or small wall display up to current monitor-based size, e.g. 80 inches. If a user is interested in larger vertical displays, a custom-built solution is the only choice and this requires a significant investment in time and money. The device presented in this on-going work fulfills most requirements for the efficient design of large-scale multi-point interaction. It is able to cover a very large interaction area up to 25 m with a single device and multiple devices could be combined to track even larger areas. The device is robust and reliable even under changing lighting conditions. It provides a low latency rate and is robust enough for intensive use during fair exhibits or other use cases, which require multipoint interaction over a long time. In this paper we briefly present the device and illustrate some applications showing that the radarTOUCH device could be easily applied in different application domains.

Related Work

Interaction on vertical surfaces has a long tradition, as this is the premier way to present information in many application scenarios. Teichert et al [1] and Baudisch [2] presented a good overview with a focus on large screens. Large multitouch walls have been presented since the first multitouch demos by J. Han in 2006 and Han's company Perceptive Pixels offers a 81" x 48" multitouch screen based on FTIR technology [3]. Large vertical interaction on a 20 m sized wall is displayed on a regular base at the German Telekom exhibit at prominent fairs like Cebit, Hannover and IFA, Berlin. The application features an optical tracking system based on DI technology with a cascade of IR cameras and tracks the interactions based on a system provided by multitouch.fi [4]. A 4m x1.2m large interactive wall was presented at EXPO 2010 featuring 8 stacked 47"

multitouch cells. One of the largest wall displays with high resolution, the HeyeWall has been extended towards multitouch interaction, recently. The original HeyeWall features a resolution of 8400 x 4200 pixels on a tiled display of size 5,0 x 2,5 meters [5]. A smaller variant of 4 x 2 m with half the resolution was recently built using FTIR multitouch technology [5].

The device presented here is dedicated to multitouch 2D-interaction on large planar surfaces. In contrast to other related work using image-based tracking approaches it is capable to scan a very large interaction space up to 25 meters. In this way, the device is related to the Laser wall presented by J. Paradiso in 2000 [6]. As the technology is based on a laser scanner, interaction is per se not bound to any specific surface but can also be used for touchless "minority report" style interaction. To our knowledge, one of the largest multitouch display worldwide so far is the RingWall at the Nürburgring, a well-known motorsport complex in Germany. It features a 45 x 2 meters multitouch surface with 34 mio pixel rendered by 15 high definition projectors and an extra-large LED wall above with 245 square meters [7]. The interaction techniques do not provide real multitouch gestures but single touch interaction of multiple users at the same time. The project was developed over 18 months and used cascade of 8 of our devices for tracking.

With the availability of the Microsoft Kinect sensor device similar "touchless" application scenarios can now be developed with small effort due to free libraries like freenect, OpenKinect, etc [8]. In contrast to radarTOUCH, Kinect even allows interaction in 3D space but the size of the interaction space is more limited than with our device.

Hardware and Software

The device is based on a distance sensor working in a two-dimensional measurement transmission mode. Inside the sensor is a laser diode whose light beam (905 nm) is fed onto a rotary mirror via an optical system. This deflection unit is moveable and rotates, guiding the laser over a predefined angular field (see figure 1). The laser generator transmits light pulses at given intervals. If these pulses strike an obstacle, they are remitted and detected by a receiver inside the device. Using the delay of the light pulses from when they are transmitted to when they are received back and the effective angle setting of the deflection unit, the measurement instrument is able to determine the exact coordinates of the object. This measurement principle is known as time-of-flight measurement (TOF). The measurements made by the scanner cover an angle range of up to 190° at a minimum angle step of 0.36° with a frequency of 25 times per second. The device can be mounted to scan horizontal and vertical surfaces and adjusted via various ceiling brackets or truss mounting systems. The maximum theoretical distance at which the system is able to detect objects is 25 meters. However, with increasing distance to the measurement object, the distance between two consecutive measurement points also increases and the system cannot always detect objects that are too small, especially at larger distances. The reliability of object detection depends strongly on the object's remission properties. Owing to the short pulse duration of 3 ns, an average power of $12 \mu\text{W}$ is not exceeded and meets the requirements of Laser Class 1 and is therefore graded as not dangerous.

The software driver realizes a simple pipeline of receiving data via Ethernet, parsing and interpretation

of data and forwarding the information to a suitable application. For our purposes, the most practical and common interface for data transmission is OSC (Open Sound Control, www.opensoundcontrol.org), which communicates via a UDP connection. Some clearly defined protocols are shown in the TUIO framework, which is the quasi-standard in the area of multi-touch (www.tuio.org). Amongst other things the device supports the 2Dcur profile (TUIO specification). Furthermore, it is possible to use the system in connection with Windows7 touch events. The device calibration is a simple process with a custom Java-based software application that allows resizing the tracking area with a simple GUI-based dialogue. Moving an object to the corner points of the desired rectangle visualize the tracked points in the software and these could be used to crop the tracking area to the desired size. The set-up typically takes only a few minutes. The tracking precision depends on the size of the tracking area but is sufficient to track arms and hand movements. It is possible to track fingers, however due to rather large size of the tracking areas for which the device is best suited, finger tracking is often not desired. In fact, for some applications we implemented a filter that combines several tracked fingers to a single tracking point.

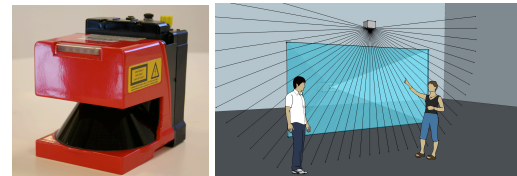

Figure 1. radarTOUCH and illustration of usage

Application Scenarios for radarTOUCH

In the following section, we briefly describe a number of applications we have built using the device. We selected two applications that should illustrate the wide application range of our device concerning the size of the interaction space and the possible application domains.



Figure 2: Large Sized Interaction on a VR Wall Display

Zoomable User Interface: The design of state-of-the-art mechatronic engineering systems requires an effective cooperation and communication between developers from different domains throughout the development process. For this purpose we developed of a zoomable interface dedicated to present a large hierarchical design model of a complex mechatronic

system, a rail-cab with inherent intelligent behavior. The large hierarchical structure of the model was illustrated by means of a dedicated visual notation used in mechatronic system design and consists of over 10.000 elements for this example, a rail cab prototype. An efficient presentation of this complex model was realized by means of a zoomable user interface [10] that renders the model in real time on a large Virtual Reality wall (4.7m * 2.6 m) with a 3840* 2160 high resolution (see figure 2). The zoomable user interface application renders the graph with a semantic level of detail, e.g. based on the zoom level different hierarchies of the graph are visualized. We found that that this visualization set-up combined with dedicated interaction techniques for selection, navigation and presentation reduces the cognitive workload of a passive audience and supports the understanding of complex hierarchical structures, similar to work presented by [11]. The interaction for navigation was realized by defining two-handed gestures for zoom and pan and for a guided presentation of the graph using a predefined tour of waypoints at different zoom levels.

Musical Interfaces: The second scenario features the development of a touchless musical interface - the radarTHEREMIN. Traditional instruments evolved over a long time to provide trained musicians with a large repertoire of interaction techniques to express themselves. Quite often the mechanical and electronic music instruments are operated with hands, feet or mouth. Hence, the challenge of successful Computer-Based musical interface design is how the designer can escape the traditional limitations of desktop interaction and how he can provide a natural interaction similar to traditional musical interfaces. Tangible and embedded interaction techniques are a promising approach to

design musical interfaces that could be well accepted, run efficiently and are fun to use. Our musical interface provides a positive user experience for multiple casual users by enabling them to jointly create harmonic expressions with an intuitive and minimal user interface. Inspired by the Theremin (see [10]), the first touchless musical interface and the first electronic instrument created in the early 20th century by Russian physicist Lev Theremin, we decided to design a gesture-based interaction that takes place freely in the air and named this application radarTHEREMIN. If the player moves her hand within a predefined interaction area, the system maps the position onto a dedicated hexagonal pitch pattern and plays the corresponding note.

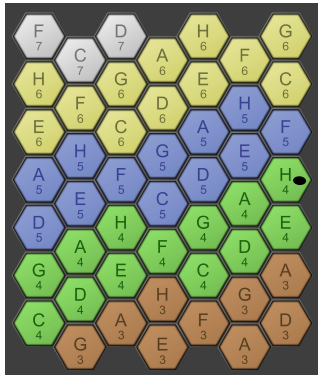

successfully match the movements of the virtual camera with the ones of the real camera. Our 3D environment consists of an ambient, tunnel like background, a platform on which the performer(s) stands and a platform for the radarTOUCH. Above the radarTOUCH there is a semi-transparent virtual screen, in which the Melodic Table graphics is shown. The notes generated by the performer are visualized as 3D hexagons appearing behind him/her. These hexagons react with an explosion like effect, if the corresponding notes get triggered, and vibrate according to the levels of the sound frequencies assigned to these notes. Other visualization techniques are currently developed.

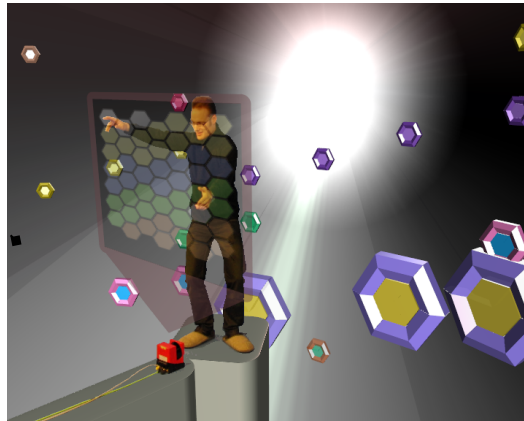

Figure 4. radarTHEREMIN in a live production within a virtual studio environment

Conclusion

This paper presented the radarTOUCH device for tracking multipoint interaction on or in front of very

large planar surfaces. We briefly described its application in two very different application domains. The interactive exploration of large hierarchical graphs was realized with a zoomable user interfaces and the concept of a touchless musical interface was implemented in virtual studio environment.

References

- [1] J. Teichert, M. Herrlich, B. Walther-Franks. Advancing Large Interactive Surfaces for Use in the Real World, in: *Advances in Human-Computer Interaction*, vol. 2010, 2010
- [2] P. Baudisch. Interacting with Large Displays. *IEEE Computer*, vol 39, no 3, April 2006.
- [3] <http://www.perceptivepixel.com/solutions.html>.
- [4] MT Case Studies. <http://multitouch.fi/case-studies>
- [5] http://infosthetics.com/archives/2009/11/ringwall_world_largest_multi-touch_multi-user_wall.html.
- [6] HeyeWall: www.heyewall.de and Multitouch HeyeWall Graz: www.cg.v.tugraz.at/CGV/VRLab/HEyeWall.
- [7] J. Paradiso, K. Hsiao, J. Strickon, J. Lifton, and A. Adler. Sensor Systems for Interactive Surfaces, *IBM Systems Journal*, Volume 39, Nos. 3 & 4, October 2000, pp. 892-914.
- [8] <http://www.kinect-hacks.com/>
- [9] C. Geiger, H. Reckter, R. Dumitrescu, S. Kahl, J. Berssenbrügge. A Zoomable User Interface for Presenting Hierarchical Diagrams on Large Displays, In *HCI International 2009*, San Diego, 2009
- [10] C. Geiger, H. Reckter, C. Pöpel, D. Paschke, F. Schulz. Towards Participatory Design and Evaluation of Theremin-Based Musical Interfaces. *New Interfaces for Musical Expressions*, Italy, 2008.
- [11] B. Bederson, J. Meyer, L. Good. Jazz: An Extensible Zoomable User Interface Graphics Toolkit in Java. In *Proc. of UIST 2000*, ACM Press, 2000.

Performative Gestures for Mobile Augmented Reality Interaction

Roger Moret Gabarro

Mobile Life, Interactive Institute
Box 1197
SE-164 26 Kista, SWEDEN
roger.moret.gabarro@gmail.com

Annika Waern

Mobile Life, Stockholm University
DSV
Forum 100,
164 40 Kista
annikaw@dsv.su.se

Abstract

Mobile Augmented Reality would benefit from a well-defined repertoire of interactions. In this paper, we present the implementation and study of a candidate repertoire, in which users make gestures with the phone to manipulate virtual objects located in the world. The repertoire is characterized by two factors: it is implementable on small devices, and it is recognizable by by-standers, increasing the opportunities for social acceptance and skill transfer between users. We arrive at the suggestion through a three-step process: a gesture-collecting pre-study, repertoire design and implementation, and a final study of the recognizability, learnability and technical performance of the implemented manipulation repertoire.

Keywords

Augmented reality, Mobile augmented reality, Gesture-based interaction

ACM Classification Keywords

H5.m. Information interfaces and presentation (e.g., HCI): Miscellaneous.

General Terms

Interaction, Augmented Reality, Interaction Design

Copyright is held by the author/owner(s).

TEI'11, Work-in-Progress Workshop

Jan 23, 2011, Madeira, Portugal.

Introduction

Mobile Augmented Reality is the use of augmented reality on hand-held devices, most notably mobile phones. When the idea of Mobile Augmented Reality (mobile AR) was proposed by Rohs and Gfeller [9], the authors explicitly stated a desire to use mobile AR to enhance interaction. Despite these early efforts, today's applications of mobile AR are typically restricted to fixed information overlays with little or no possibilities for interactivity. It is symptomatic that mobile AR is often described as using a 'magic lense' metaphor [6], as if pointing the device towards a marker or object will reveal its hidden, inner properties. The manipulation of those inner properties is seldom prioritized, and impoverished at best. This becomes particularly problematic for games, as these rely on players being able to manipulate the game content

We suggest a repertoire of manipulations for mobile phone AR, based on gesture interaction. Our goal is to find a repertoire that is implementable, reasonably natural and learnable, but also performative, allowing by-standers to grasp something about what users do with their devices.

Performative Interfaces

Reeves et al [7] have developed a classification of user interfaces from the perspective of a by-stander rather than the direct user. They distinguish between performative, secretive, magic and suspenseful interfaces, depending on whether by-standers can observe the interaction and/or the effects of the interaction. A performative interface is one where by-standers can observe both the action and the effect, a secretive interface is one where both the action and the effect is invisible, a magic interface one where the

action is invisible but the effect observable, and finally a suspenseful interface is one where the action is visible but the effect is not.

Camera-based AR interaction on mobile phones tends to be suspenseful (as the action may be visible but the effect only is visible on the screen). However, if the interaction is implemented through well-defined and recognizable gestures, by-standers could be able to infer what the effect is. Thus, handheld mobile AR could be designed to be more performative than most alternative interaction techniques.

We believe that there are several advantages to creating performative interaction models. Performative interfaces enhance the social negotiation process as the users' current activity is (partly) visible, and the social transfer of skills is also enhanced as by-standers can (to some extent) learn by mimicking the actions of another user.

Design Study Goals

The objective of our project is to create a repertoire of manipulative gestures, where a mobile phone is used to manipulate virtual objects residing in the physical world. In designing this repertoire, we need to take several factors into account: it needs to be at least to some extent natural and learnable, but also implementable and performative.

Repertoire of manipulations

We first selected the manipulations for which to design gestures. In selecting these, we took inventory of previous AR demonstrators, to look at what kinds of manipulations they have sought to realize, as well as envisioned some applications of our own. Some of our

inspirational sources have used physical manipulation of markers rather than the virtual content in order to realize interaction (see e.g. [5]); a simpler but from a usability perspective often clumsy solution, as it requires the user to at the same time hold the camera and manipulate one or several markers.

Prestudy

In order to collect possible gestures, a gesture manipulation system was simulated using an iPhone with the camera activated, a fiducial marker and a physical object in place of virtual content. Through the mobile, the participants would see the marker and the physical object. The movements of the object were simulated by a person turning and moving the physical object to illustrate the intended effect. The participants were first shown the intended effect, and then asked to think of a gesture that could cause the effect.

The physical manipulation of a physical object proved to be a good way to communicate the intended effect of gestures, and all participants were able to think of gestures for most manipulations. However, participants found it more difficult to create gestures for some of the manipulations than for others. The gestures invented for these were also more diverse.

The rotations, enlarge, shrink and picking up the virtual object are some of the most relevant results from the prestudy. Eight out of the fourteen participants invoked the rotations by flicking the mobile (clockwise or counter clockwise) around the same axis as the AR object is to be rotated. This action would start the rotation which would remain until the mobile is flicked in the opposite direction. Seven participants enlarged or shrank by pressing and holding the screen of the

mobile, moving closer or farther away from the marker and releasing the screen. However, five of them got closer to the marker to enlarge and farther away to shrink while the other two to get closer to shrink and farther away from the marker to enlarge. We believed this difference is due to the lack of feedback on how the object was enlarged and shrank during the simulation done prestudy. Finally, the pick up action was mainly invoked by performing a 'scooping up' gesture with the phone. The difference between this solution and the others gotten in the study is that participants perform this gesture in different ways even though the concept they are trying to perform is the same.

Design of the manipulations

Based on the gesture collection study, we proceeded to design a gesture repertoire for manipulations. In doing so, we looked at technical feasibility, repertoire consistency, and lastly the choice of the majority (if there was a large difference in preferences).

Implementation

For the second study, we implemented gestures that would rotate, enlarge, and shrink the object. For enlarge and shrink we implemented the two identified variants, in order to compare them in the evaluative study. For the rotations, our primary choice was the 'start and stop' version described above. We also implemented a version of the movement where the object would rotate in clearly defined steps, so that a single flick would make the object move one step.

The implementation runs on a Nokia N900 with Maemo 5 as operating system. The movement recognition uses accelerometer data as well as visual information from the marker tracker. The ARToolKitPlus 2.2.0 library was

used to implement a basic augmented reality application to interact with.

Evaluative study

Using the implementation, we did a second study of the gesture repertoire. In this study, the recruited participants had no previous experience or understanding of mobile AR. In this study, we first asked for the immediate interpretation of the manipulations when watched from a third person perspective, and only then handed over the phone to the participants to use by themselves.

Immediate impressions

Seven (7) of the nine participants' immediate impression was that the study organiser was using the camera or taking pictures. Three of them (aged 15-21) added that it was also possible that 'this was some kind of game', indicating that the gestures might have seemed more manipulative than ordinary camera gestures. The rotation manipulation was interpreted as a rotation, a turning, or a switching action, possibly in order to navigate through a set of options. The enlarge manipulation was interpreted as zooming with the camera (5 participants) or taking a picture (3 participants). All participants were able to identify the location of the invisible object as on or near the marker.

Usage experience

Eight out of the nine participants could perform the gestures to enlarge or shrink with a few or none instructions. The implementation of this gesture is robust and its usage fairly intuitive according to the participants. The rotations are not as robust. All of

them required more instructions and practice to perform the gestures correctly.

Of the two implemented versions of enlarge and shrink, the evaluation group was as divided as in the original study: five participants preferred that the object would shrink when moving closer and four preferred the opposite. There was no clear preference concerning the continuous or the step-by-step implementation of the rotations: most users liked both solutions.

Future work

We have shown that gesture-based interaction in mobile AR applications is implementable and that it is at least partially recognizable by by-standers. As our next step, we plan to explore the function in a real application context which will be a pervasive game.

Acknowledgements

The authors wish to thank the anonymous study participants for their valuable input, and the personnel at Lava for admirable support.

References

- [1] Bradley, D., Roth, G. and Bose. P. 2009. Augmented reality on cloth with realistic illumination. *Journal of Machine Vision and Applications* 20(2).
- [2] Chen, L-H, Yu Jr, C, and Hsu, S.C. 2008. A remote Chinese chess game using mobile phone augmented reality. *Proc. ACE'2008*. Yokohama, Japan.
- [3] Comport, A.I., Marchand, E., Pressigout, M., and Chaumette, F. 2006. Real-Time markerless tracking for augmented reality: The virtual visual servoing framework. *IEEE transactions on visualization and computer graphics* 12(4) 615 - 628.

- [4] Harvainen, T. Korkalo, O. Woodward, C. 2009. Camerabased interactions for Augmented reality. Proc. ACE'2009, Athens, Greece.
- [5] Kato, H., Billinghamurst, M., Poupyrev, I., Imamoto, K., Tachibana, K. 2000. Virtual object manipulation on a tabletop AR environment. Proceedings International Symposium on Augmented Reality (ISAR'00), 111-119.
- [6] Looser, J., Billinghamurst, M., and Cockburn, A. 2004. Through the looking glass: the use of lenses as an interface tool for Augmented Reality interfaces, Computer graphics and interactive techniques in Australasia and South East Asia. 204 - 211.
- [7] Reeves, S., Benford, S., O'Malley, C., and Fraser, M. 2005. Designing the spectator experience. Proc. CHI'05. Portland, Oregon. 741-750.
- [8] Rohs, M. 2005. Real-world interaction with camera phones. Ubiquitous Computing Systems. LNCS Volume 3598.
- [9] Rohs M. and Gfeller, B. 2004. Using camera-equipped mobile phones for interacting with real-world objects. Proc. Advances in Pervasive Computing. Vienna, Austria. 265-271.
- [10] Rohs, M. and Zweifel, P. 2005. A conceptual framework for camera phone-based interaction techniques. Proc. Pervasive'05, LNCS No. 3468. Munich, Germany.
- [11] Wang, j, Canny, J and Zhai, S. 2006. Camera phone based motion sensing: Interaction techniques, applications and performance study. Proc. UIST' 2006, Montreux, Switzerland.
- [12] Watts, C. Sharlin, E. 2008. Photogeist: An augmented reality photography game. Proc. of ACE'08. Yokohama, Japan.
- [13] Wetzel, R., Waern A. Jonsson, S., Lindt, I., Ljungstrand, P. and Åkesson, K-P. 2009. Boxed pervasive games: An experience with user-created pervasive games. Proc. of Pervasive '09. Nara, Japan.
- [14] Xu, Y., Gandy, M., Deen, S., Schrank, B., Spreen, K., Gorbisky, M., White, T., Barba, E., Radu, J., Bolter, J. and MacIntyre B. 2008. BragFish: Exploring physical and social interaction in co-located handheld augmented reality games. Proc. ACE'08, Yokohama, Japan.

TEI 2011 Bodies, boogies, bugs & buddies: Shall we play?

Elena Márquez Segura

Mobile Life Centre at Interactive Institute
Forum 100
164 40 Kista, SWEDEN
elena@mobilelifecentre.org

Carolina Johansson

Mobile Life Centre at Interactive Institute
Forum 100
164 40 Kista, SWEDEN
lina@mobilelifecentre.org

Jin Moen

Movinto Fun
Årevägen 138
83013 Åre, SWEDEN
jin@movintofun.com

Annika Waern

Mobile Life Centre at Stockholm University
Forum 100
164 40 Kista, SWEDEN
annika@sics.se

Copyright is held by the author/owner(s).
TEI'11, Work-in-Progress Workshop
Jan 23, 2011, Madeira, Portugal.

Abstract

Movement based interaction is a growing field especially within games, such as the Nintendo Wii and Kinect for Xbox 360. However, designing for movement-based interaction is a challenging task in mobile settings. Our approach is to use context design for designing such games and in this paper we present the experiences from a workshop targeting the design of social full-body dance games. The workshop explores how movement based games can be supported by social interaction and external influences (in particular music and beats) in addition to the sensing and feedback capabilities of a limited device, to create a complete and engaging experience. Although basing our design on an existing device, our focus is on the context of its use rather than its functionalities, to encourage an engaging behavior. Findings from this first workshop form the basis for a design exercise where we suggest a range of full-body interaction games.

Keywords

Body interaction, gestures, movement, body, BodyBug, workshop, experience, design process, game, dance, children.

ACM Classification Keywords

H5.m. Information interfaces and presentation: Miscellaneous.

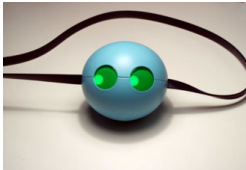

Figure 1: The BodyBug

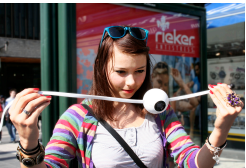

Figure 2: Playing with the BodyBug

Introduction

Current movement-based games create fun by mimicking real-world movements in the game (e.g. a hook in boxing in *Motionsports* [10]). Thus, much of the research effort focuses on the development of more sophisticated sensing technologies embedded in the game platform to support accurate measurements of player movements (i.e. Kinect for Xbox 360 [5], or PlayStation Move Motion Controller and Eye Camera [12]). However, it is hard, if not impossible, for a machine to sense the meaningfulness of human gestures with all its nuances, attributes, and richness. In order to create meaningful experiences, it does not suffice to rely on the technology as such. The technology is not yet, and may never become, ready to be compared to our proprioceptive and kinesthetic awareness [6].

In this paper, we challenge the premise that the fun needs to be exclusively sustained and supported by sophisticated sensing technologies. Our starting point is an existing sensing device, the BodyBug (see Figure 1), whose limited sensing capabilities encouraged us to reformulate and rephrase the problem of designing and sensing a kinaesthetic game. Instead of encouraging behavior merely through technology design and implementation, we propose an alternative approach in which we also utilize *context design*. Although the functionality of the BodyBug lies at the core of our design process, the intention is to design not only its function but also the context of its use, to encourage an engaging behavior. Our claim is that contextual support for action may cater to the richness and meaningfulness which technology fails to provide on its own.

Background

The BodyBug [4] is a small movement companion (see Figure 2) developed by Movinto Fun [11] and originally created by Moen [8, 9] as a result of interdisciplinary research merging interaction design and dance education. The current prototype is a portable and mobile sphere-shaped device running on a non-elastic leash (see Figure 1). The sphere contains a three axial accelerometer, a motor and a gearbox. The device senses the user's movements and provides feedback in terms of sound, light (by means of two eyes consisting of 6LEDs each), an OLED monochrome display, and its own movement along the leash.

The problem

As stated by Benford [2], the movements of a user in relation to a moveable, physical or mobile system can be analyzed in terms of what is i) expected (movements independent of any specific application, naturally performed by the users), ii) sensed (movements that can be measured by the system, due to available sensing technologies), and iii) desired (movements required by a given application). The BodyBug was created in order to support free and natural full-body movement interaction [8, 9]. Therefore, the desired movements ideally overlap with the expected movements, and should also be possible to sense (see Figure 3).

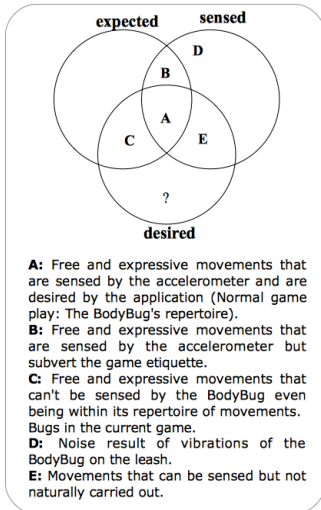

Figure 3: The expected, sensed and desired for the BodyBug

However, as with many other systems [7], such an overlap is difficult to achieve. Even if the accelerometer could sense almost every movement the user performs, it would be out of the reach of the BodyBug's computational capability to identify and classify the movements properly and provide the meaningful response and feedback the user would expect. Thus, if the performance of a design relies on the technology to perform well and the capabilities are limited as in this case, a breach in the interaction with the system can be expected with the consequent frustration on the side of the player. This effect was apparent in a previous user study with the BodyBug [16, 17].

The workshop

This paper reports on the experiences from a design workshop (see Figure 4), which is the first stage of an iterative design project targeting the design of social full-body dance games. The aim of the workshop was to create an engaging context through the design of a game activity using social interaction and the use of external stimuli in terms of music and sound. These stimuli, due to their profound and strong bound to dance, are chosen to enhance a playful context and guide the user through the game. For the workshop, we designed multiplayer games in which social interaction, rather than the BodyBug, could partially assume the control over the rules and goals of the game, alleviating the burden on the BodyBug. In an attempt to shift the focus from the device itself to the social environment surrounding the players and to the unfolding activity per se, we decided to switch the BodyBugs off. Findings from this workshop are used as a basis for the next game design stage with a certain degree of implementation, as will be further described in the last section of this paper.

Participants and structure

The project targets players in the age range of 10-12. At this age, children are old enough to grasp the rules of a game [1, 3]. Inspired by "Head Up Games" [13, 14, 15], we designed four small games, to be performed with and without the BodyBug and with and without music. During the workshop we also included some older children aged 13-14 to compare the kinesthetic awareness of the two groups and get a feeling for the right difficulty level for the game. In total, 20 children of ages 10 to 14 years participated in the workshop. Two children were boys. All participants were recruited from a dance school and hence familiar with physical expression. The most important findings were found in relation to the game "The Mirror", in which participants in pairs were asked to mirror each other's movements (one would play the role of movement 'generator' and the other one would play 'the image' and try to mimic the movement of the first one), and the game "The Bomb" in which the children were asked to pass an imaginary bomb between them until it exploded.

Findings

Video analysis and on-site observations from the workshop yielded a number of interesting findings. Here we focus on those relevant to contextual design.

Social interaction – cooperation, competition, strategy and revenge

The different ages of the participants did affect, to a large extent, how the game design influenced the activity. The attitude, kind of movements, the degree of influence from external stimuli (music, beats and contextual sound), and even the way of having fun showed to be all quite age dependent.



Figure 4: Workshop Games. From top to bottom: “The Bomb” (younger children); “The Mirror” with the BodyBug and beats (older children); “The Mirror” with music and without the BodyBug (younger children).

Older children focused more on cooperation and collaboration among the group. The music in “The Mirror” was very fast (i.e. “Bad Romance” by Lady Gaga) and difficult for ‘the image’ to mimic accurately. Therefore collaborative tricks were common among this group, such as ‘the generator’ often repeating short sequences of movements, until ‘the image’ managed to repeat that sequence; or ‘the generator’ using a slower pace when initiating a new movement, and then speeding it up once ‘the image’ was able to perform that movement.

Younger children, on the other hand, were less interested in their ‘image’ mirroring their movements accurately. Instead, they focused more on dancing in keeping with the fast music and tended to forget the BodyBug, which was often just hanging in its leash from their wrists. Sometimes, the ‘image’ performed similar but not identical movements to those performed by ‘the generator’, trying to maintain the main features and quality of the movements, but in a free way (e.g. moving the same body parts and in the same rhythm, but, where ‘the generator’ would shake the shoulders up and down, ‘the mirror’ would shake the shoulders forwards and backwards).

In the game “The Mirror”, competition was introduced by the only male pair, who took turns to perform their movements with increasing difficulty, as if they were in a dance battle. In the game “The Bomb”, strategy and revenge were also apparent among this group (e.g. one boy would keep the bomb until the very last moment before the explosion and then he would throw it to somebody else who, in turn, would return it back. This same situation would be repeated again and again and every single player would return the bomb to the first

boy). Younger children were more engaged in this game than the older ones.

External stimuli – music, beats and contextual sound
 External influence, such as music, beats (beeps that marked slots of time for turn taking) and contextual sound (beeps and a bomb explosion sound) were quite significant to help building and enhancing a rich context for the games. When “The Mirror” was performed without music but beats in the background, the movements were less fluent and more like sets of single easy steps and arms gestures. The lack of music also led to a higher focus on using the BodyBug. The beats seemed to help the children by giving them time to think about the next movement and time to memorize a sequence of movements to repeat later on.

In the game “The Bomb” the players used their BodyBugs to pass an imaginary bomb to each other around the circle in where they were placed. Using sound (a repeated beep that increased in frequency) in “The Bomb” helped to create a believable story. The stress introduced, due to the increasing frequency, seemed to ask for fast actions and reactions, causing much laughter and intensified attention from the players.

Lessons learned and next steps

Findings described above suggest that both the social interaction through the multiplayer function and the external sound and music enriched the experience and helped in creating a context for game. We will therefore include both beats and sound in the next stage of the game implementation to both guide the players through the game and help to build context around the activity. Younger children were more susceptible to engage in

competition, strategy and revenge, especially seen in the game "The Bomb".

Older children were more open to cooperation, such as when they developed tricks in "The Mirror" to cope with the fast music. The movement awareness and accuracy within the younger group was observed to be not as developed as within the older group. The youngest were, on the other hand, more enthusiastic about the games. Regarding the final game development, this greater enthusiasm and engagement in the game seen in the younger group, take priority over a higher degree of accuracy in movements seen in the older children. Therefore our target group remains children of ages 10 to 12 years, which means that we may deal with children doing different movements that they think are the same, as observed in the game "The Mirror". This lack of accuracy in performing movements adds an extra difficulty if the BodyBug is to be designed for movement recognition and classification. Therefore, this gives us another reason to discard any design that requires detailed recognition of precise movements and rather aim for building a rich context through social interaction and external stimuli.

Next stage of our project will take these findings as a basis for a design and implementation phase, in which three small full-body interaction games will be developed, some of them partially implemented, and played with an active - turned on - BodyBug. The BodyBug will be responsible for reacting to movements and guiding the players through the different stages of the game, rather than determining the outcome or the fulfillment of the game rules. Instead, we will rely on the social context of the game - the players themselves - to decide the outcome and to ensure that the game

rules are adhered to. These new games will be studied in a second workshop.

One concrete design example, that we are in the process of implementing and testing, is a game which rewards fast interaction in line with the game "The Bomb". Each child will pick a movement with which to be identified as if it was her tag. Every child will perform her movement during a slot of time marked with beeps by the BodyBug. Then, the BodyBug will select randomly a leader within the group to whom the rest will immediately mimic as accurately as possible. The leader, rather than the BodyBug, will decide and point to the child who first and most accurately mimicked the leader's movement correctly and this child will introduce manually, or rather bodily by means of a gesture like shaking, the score in her BodyBug's scoreboard. In this way, the BodyBug will guide the children through the different stages of the game by means of sound and light (marking the different slots of time and choosing a leader), but it will be released from the responsibility of both judging the children's movement and making sure the rules are fulfilled; responsibilities that will lean on the players instead.

Example citations

[1] Acuff, D.S. What Kids Buy and Why. The Psychology of Marketing to Kids. The Free Press, New York, USA, 1997.

[2] Benford, S., Schnädelbach, H., Koleva, B., Anastasi, R., Greenhalgh, C., Rodden, T., Green, J., Ghali, A., Pridmore, T., Gaver, B., Boucher, A., Walker, B., Pennington, S., Schmidt, A., Gellersen, H. and Steed, A. Expected, Sensed, and Desired: A Framework for Designing Sensing-Based Interaction. ACM Transactions on Computer-Human Interaction, Vol. 12, No. 1, 2005, 3- 30.

- [3] Bergen, D. and Fromberg, D.P. Play from Birth to Twelve and Beyond: Contexts, Perspectives, and Meanings. Garland Publishing, Inc., New York and London, 1998.
- [4] BodyBug@. <http://www.bodybug.se>
- [5] Kinect for Xbox 360. www.xbox.com/en-US/Xbox360/Accessories/Kinect/kinectforxbox360
- [6] Lephart, S.M, and Fu, F.H, Proprioception and neuromuscular control in joint stability, Human Kinetics (2000), XVII.
- [7] Loke, L., Larssen, A.T., Robertson, T. and Edwards, J. Understanding movement for interaction design: frameworks and approaches. In Per. Ubiquit. Comput. (2007)
- [8] Moen, J. KinAesthetic Movement Interaction: Designing for the Pleasure of Motion. Doc. Thesis, KTH, Num. Anal. and Comput. Science, NADA, 2006.
- [9] Moen, J. From Hand-Held to Body-Worn: Embodied Experiences of the Design and Use of a Wearable Movement-Based Interaction Concept. In TEI (2007), Chap. 6, 251-258.
- [10] MotionSports. www.motionsportsgame.com
- [11] Movinto Fun AB. <http://www.movintofun.com>
- [12] PlayStation Move Motion Controller and Eye Camera. www.us.playstation.com/ps3/accessories/
- [13] Soute, I. HUGs: Head-Up Games. In Proc. Doc. Consortium IDC 2007, ACM Press (2007), 205- 208.
- [14] Soute, I. and Markopoulos, P. Head Up Games: The Games of the Future Will Look More Like the Games of the Past. In IFIP 2007. INTERACT, LNS 4663, Part III, 2007, 404-407.
- [15] Soute, I., Markopoulos, P. and Magielse, R. Head Up Games: combining the best of both worlds by merging traditional and digital play. In Pers. Ubiquit. Comput. 2009.
- [16] Tholander, J. and Johansson, C. Body, Boards, Clubs and Bugs: A study on bodily engaging artifacts. In CHI 2010. ACM Press (2010), 4045-4050.
- [17] Tholander, J., Johansson, C. (2010). Design qualities for Whole Body Interaction – Learning from Golf, Skateboarding and BodyBugging. NordiCHI'10, October 18 - 20, Reykjavik, Iceland, ACM Press

MagInput: Realization of the Fantasy of Writing in the Air

Hamed Ketabdar

Deutsche Telekom Laboratories, TU
Berlin
Ernst-Reuter-Platz 7, Berlin, Germany
hamed.ketabdar@telekom.de

Amin Haji Abolhassani

McGill University, Montreal, Canada
amin@cim.mcgill.ca

AmirHossein JahanBekam

Deutsche Telekom Laboratories,
Ernst-Reuter-Platz 7, Berlin, Germany
amirhossein.jahanbekam@telekom.de

Kamer Ali Yüksel

Sabancy University, Istanbul, Turkey
Kamer@sabancy.edu

Abstract

Writing in the air has been a fantasy for humans for a long time. In this work, for the first time, we present a modern user entry approach that utilizes the invisible magnetic field around a mobile device for the purpose of text inputting. To that end, we have exploited the intra-effect between the magnetic fields of a magnetized element and the embedded magnetic sensor which can be found in new generation of mobile devices, such as Apple iPhone 3GS and Google Android. The temporal characteristics of the magnetic field of the sensor can, then, be used as an interface between the user and the device. Input patterns are compared with a dictionary of prototypes to find the intended character. Thus, the magnetic data entry raises the flexibility of user-device interaction from a 2D interface on a mobile device to the 3D space around the device. The method we employ here is tailored to deal with the inherent limitations of current interaction methods in mobile devices such as small screens, necessity of direct contact between the device and the user, small keyboards, demand for visual resources of the user and difficulty of entering special characters. The accuracy of the results renders our technique as a promising interaction method while imposing no change in hardware or physical specifications of the device.

Copyright is held by the author/owner(s).

TEI'11, Work-in-Progress Workshop

Jan 23, 2011, Madeira, Portugal.

Keywords

3D Around Device Interaction, Text (Digit) Entry, Handheld Devices, Magnetic (Compass) Sensor for User Interface

ACM Classification Keywords

H5.m. Information interfaces and presentation (e.g., HCI): Miscellaneous.

Introduction

Compass, a human made navigational tool, has been widely employed to facilitate the piloting difficulties in the past centuries. An ordinary compass, by itself, is nothing more than a magnetized needle that pivots on an axis and tends to stay aligned with the earth's north-south magnetic field. Being in telecommunication era, we are facing a rapid growth of electronic mobile devices that integrate more and more facilities every day. In the very recent years, electronic magnetic sensors have been combined with the cell phones to enhance the functionality of the phone's built-in navigation system, which is typically the GPS. We found, however, that the usability of the compass is beyond navigational applications and can be extended to the context of human computer interaction (HCI).

As we know, a moving magnet that travels in the 3D space around a compass-enabled device interferes with its surrounding magnetic field. The pattern of this interference, then, results in generation of temporal patterns in X, Y and Z axes of the sensor. Thus, these patterns can be used to build a touchless interaction framework as a means of communication between the user and the device. In other words, the user can generate a specific gesture which in turn creates a temporal pattern in the magnetic field axes of the

device. This pattern, then, can be compared against the pre-recorded templates to be labeled as an observation of one of them.

This touchless input method addresses some of the limitations of common input methods such as touchpads. For instance, a magnetic rod or a magnetic ring can use the 3D space around the device which is considerably broader than the surface of the touchpad. Additionally, since the magnetic field can penetrate through occluding objects, it allows for interactions even though the device is concealed by other objects. This is in contrary with touchpads where interactions are only possible if the user and the device are in direct contact. This feature of the proposed touchless technique will allow interactions through occluding objects such as the fabric between a user and a device in a pocket or the protecting cover of the phone itself.

Moreover, acquiring this utility does not impose major changes in physical specifications of the device which is a notable advantage in small mobile devices. Replacing keypads or touch screens with such a data entry technique in small mobile devices allows saving cost, complexity and physical space in design. Compared to keypad or touch screen, a magnetic sensor can be much simpler, smaller and cheaper, and can be internally embedded. We believe that using magnetic sensors in mobile devices leads to a significant change in design and usability of tangible and wearable devices in the upcoming future.

Magnetic field interaction has also been proposed for gesture based interaction with user on mobile devices [1] and tangible devices [2].



Figure 1. Entering text(digit) using the space around the device. The user simply draws the digits in the air using a properly shaped magnet taken in one hand.

The idea is partly inspired by Around Device Interaction (ADI) framework which proposes using space around the device for interaction with the device. Around Device Interaction (ADI) has been investigated recently as an efficient interaction method for mobile and tangible devices. ADI techniques are based on using different sensory inputs such as camera, infrared distance meter, touch screen at the back of device, proximity sensor, electric field sensor, etc. ADI concept can allow coarse movement-based gestures made in the 3D space around the device to be used for sending different commands such as turning pages (in an e-book or calendar), controlling a portable music player (changing sound volume or music track), zooming, rotating, etc.

In this article we propose a novel application for handwritten digit recognition approach that is built up on the above mentioned magnetic input technique. In the next section, we have discussed the advantages of

using magnetic data entry in detail. In section 3 we have elaborate on our proposed approach for digit recognition. In chapter 4 the experimental results and evaluations of our technique are presented. Then in chapter 5, we have given a reference to our implemented application on a mobile device and we have concluded the paper in section 6 where also some future steps to be taken are suggested.

MagInput in a closer look

The classic interaction between a user and a mobile device is usually carried out through a text entry medium such as a keypad or a touch screen. However, limited versatility of keypads (i.e., only two or three defined function for each key) and size restrictions of both keypads and touch screens are some of the limitations of these classic media. The smaller the keypad, the more chances there are that the user presses a wrong key and on the other hand increasing the size of the keypad will result in a larger phone; hence, defining a proper size for keypads has always been controversial.

In the current work, we propose a new technique for text (digit) entry which overcomes the limitations of existing keypad and touch screen based input utilities. Our method expands the text entry space beyond the physical boundaries of a device and uses the space around the device for entering textual data.

The basic idea is to draw gestures similar to characters in the 3D space around the device using a properly shaped magnet (see Figure 1). Movement of the magnet in a shape resembling a certain character changes the temporal pattern of the magnetic field surrounding the device and consequently can be sensed

and registered in the embedded magnetic sensor of the mobile device. This pattern can then be matched against templates associated to each character. In the present work, we primarily focus on entering digit data; nonetheless, other characters, symbols or textual commands can be captured analogously.

Since magnetic field can penetrate through occluding objects, the device is not required to be directly exposed to the magnet. Data entry process can be done even if the device is in a pocket or bag. For instance, the user may be able to dial a number, enter a pin code, or select an album without taking the mobile device out of his pocket/bag.

The fact that such data entry approach doesn't entail the user's visual recourses makes MagInput a practical solution for visually impaired patients. Moreover, in situations such as driving a vehicle where the visual system of the driver is occupied with critical tasks, this data entry approach can be a solution to the problems associated with the classical, vision-demanding data entry techniques.

Digit recognition

In order to recognize the pattern of user's hand movement, the data obtained from the magnetic sensor is projected on X, Y and Z axes. Collecting these data in temporal order forms a 3 dimensional sequence vector. By visualizing this sequence vector, we can observe that these samples form some sort of winding, tangled scratches in the 3D space. A practical system should be able to recognize these sparse trajectories by comparing them against a very limited number of pre-recorded samples. Using popular tree based classifiers or neural networks in this context, though, requires

considerable amount of samples to be able to provide acceptable resolutions. Therefore, we propose to apply a template matching approach, called Dynamic Time Warping (DTW) [3], which is a suitable method for measuring similarities between two signal sequences which may vary in time or speed. DTW generates a similarity measure which is based on the distance measurements between two sequences and can operate with a limited number of templates and still generate very accurate results.

In the context of our model, DTW associates each point of a test signal to a point in a template signal. These mappings between the two signal points expand into the first row and the first column in a distance matrix. All inner units of this matrix are evaluated as the minimum accumulated cost of traveling from one unit through its neighbors to the element (1, 1). The last item in DTW distance matrix represents the minimum cost of moving from one signal to another and therefore the distance of two signals.

In this work we have developed a multi-dimensional DTW that takes the Euclidean distance of the signal points into account. In order to better enhance our results, we also have used the derivative of the signal values with respect to time which leads to more reliable and accurate results [1].

Our results in the experiments section confirms that even with limited number of templates, using DWT can lead to a good performance. Moreover, DWT is a powerful classifier when it comes to classifying discrete trajectories. This is a crucial point in drawing digits like 4 and 7 that user may draw them with one or two strokes.

Experiments and evaluation

We invited 8 subjects to take part in our experiments. We asked each subject to draw, in the space around the mobile device, 10 digits (from 0 to 9) by having a magnet in their hands. For each digit, we collected 15 different samples. The data classification is performed by template matching using DTW.

We have run an eight-fold cross validation on each subject's sampled data and on each fold we have increased the number of templates by 1. Figure 2 represents the experimental results of using DTW to determine the user's gesture. Each curve in the graph represents the accuracy of the model to infer the subject's digit versus the number of templates used as the prototype of each digit. As we can see, the DTW algorithm converges very fast after having 3 to 4 templates for each digit which means that even if the number of templates is limited, a very good accuracy can be obtained in our method. This feature is especially very important in practical mobile applications where the user may not want to enter many templates for each digit. Table 1 illustrates the average results, as well as the standard deviation, of classification for all users with respect to the number of templates that was used for classification. The average result shows the average accuracy of our model given different number of templates and the standard deviation gives us an estimate about the sparseness of the accuracies obtained in each row. For instance the standard deviation of 0.092 in the second row implies that the accuracy of the model in inferring the user's gestures has a narrow distribution around %81 which means that the results obtained from the model are highly reliable even if only two templates are used in the DTW classifier.

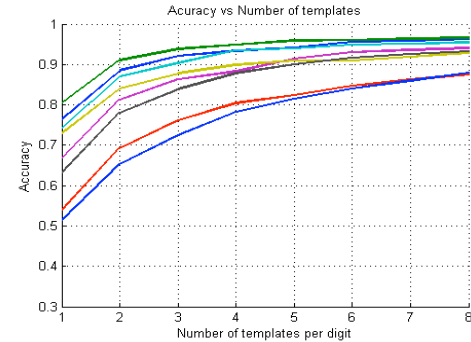

figure 2. Accuracy vs. number of templates. Each curve corresponds to the data obtained from one user. It can be seen that DTW reaches to an acceptable accuracy by having only 3 or 4 templates for each digit.

Having more templates, on the other hand, entails more processing resources. According to our experiments, the performance of the application for having one additional template for each digit approximately declines by half. To make a compromise between performance and accuracy, thus, we suggest applying 3 or 4 templates for each digit. This fact can be easily observed in figure 2 where a sharp curvature occurs when the number of templates is around 3 or 4.

In the previous section, we mentioned that using the derivative of the sample points in the DTW improves the accuracy of the algorithm. In table 2, we have compared the accuracy rate of DTW in two scenarios: a) where the derivative is used and b) where only the temporal samples are taken into account.

No. of Templates	Average Accuracy	Standard Deviation
1 Template	0.6736	0.105
2 Templates	0.8059	0.092
3 Templates	0.8535	0.075
4 Templates	0.8829	0.061
6 Templates	0.9134	0.046
8 Templates	0.9302	0.035

Table 1. Average accuracy and standard deviation with respect to the number of templates used for classification in the DTW classifier.

	Average	Standard Deviation
Without Derivation	0.5675	0.156
With Derivation	0.8829	0.061

Table 2. Using DTW with and without derivative of the signal value. The number of templates used in both cases is 4.

As we can see, the results improve when derivatives of the samples are used. Time derivative operation acts as a high pass filter, remove the effect of earth magnetic field, and highlights information related to movements of external magnet.

USER ID	1	2	3	4	5	6	7	8
MLP (%)	92	77	75	86	88	78	62	62
DTW(%)	93	94	80	93	88	89	87	78

Table 3. User-specific classification accuracy obtained by using MLP and DTW classifiers. DTW uses 4 templates while MLP uses 14 templates (training samples).

We have tested our data against multilayer perceptron (MLP) as well. We set up a ten-fold cross validation and adopted an MLP for the classification process. For using MLP classifier, we extract some features mainly based on mean and variance of signals in the gesture. Table 3 shows a comparison between a DTW with 4 templates and the MLP classifier results. It can be seen that DTW outperforms MLP even with such small number of templates.

Magiwrite: demo application for touchless digit entry

In order to demonstrate our work, we have developed an application on an Apple iPhone 3GS mobile phone that uses its magnetic sensor to interact with a user for digit entry. The demo application allows user for registering a number of templates for each digit. The application is then able to recognize new samples of digits written in the air in real time manner.

References

- [1] Ketabdar H., Yüksel, K. L., and Mehran Roshandel. MagiTact: Interaction with Mobile Devices Based on Compass (Magnetic) Sensor. *IUI'10*, 2010.
- [2] Harrison, C., and Hudson, S. E. Abracadabra: Wireless, High-Precision, and Unpowered Finger input for Very Small Mobile Devices. *UIST'09*, 2009.
- [3] G.A. Ten Holt, M.J.T. Reindersa, and E.A. Hendriksa, Multi Dimensional Dynamic Time Wrapping for Gesture Recognition. *IEEE International Workshop on Automatic Face and Gesture Recognition*, (2007), pages 272-277.

2D Tangible Code for the Social Enhancement of Media Space

Seung-Chan Kim

HRI Research Center, KAIST
291 Daehak-ro, Yuseong-gu,
Daejeon, 305-701, Korea
kimsc@robot.kaist.ac.kr

Dong-Soo Kwon

HRI Research Center, KAIST
291 Daehak-ro, Yuseong-gu,
Daejeon, 305-701, Korea
kwonds@kaist.ac.kr

Andrea Bianchi

HRI Research Center, KAIST
291 Daehak-ro, Yuseong-gu,
Daejeon, 305-701, Korea
andrea@kaist.ac.kr

Soo-Chul Lim

HRI Research Center, KAIST
291 Daehak-ro, Yuseong-gu,
Daejeon, 305-701, Korea
limsc@robot.kaist.ac.kr

Abstract

In this paper we propose a two-dimensional tangible code and rendering method to enhance the user experience in social media spaces. The proposed media can be shared and physically experienced through current social network platforms such as microblogs because the proposed code follows the ordinary image formats. In terms of a physical representation of the proposed media, we utilized haptic feedback as an output modality. With the proposed conversion algorithm, haptic information in a Cartesian coordinate system is directly calculated from the proposed images. As a work in progress, sensory substitution with vibrotactile feedback is described.

Keywords

Tangible code, social interaction, sharing experience

ACM Classification Keywords

H.5.2 [Information Interfaces and Presentation]: User Interfaces-Haptic I/O.

General Terms

Algorithms, Design

Copyright is held by the author/owner(s).

TEI'11, Work-in-Progress Workshop

Jan 23, 2011, Madeira, Portugal.

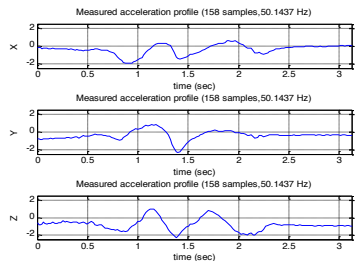

Figure 1. An example of captured motion data (3-axis acceleration)

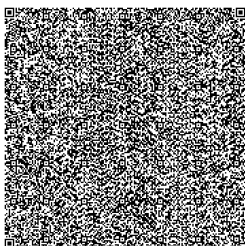

Figure 2. An example QR code that contains all of the logged gesture data (upper) and URL information (bottom)

Introduction

Among the many types of media, people interact with 2D images such as photos or paintings as part of their common computing activities. In terms of interpersonal communication in an HCI context, images have played a significant role in enhancing the social experience in media spaces, as reported in previous research [6]. Microblogs such as *Twitter*, the use of which has exploded recently, also utilize these types of images to augment the text-based experience. In fact, many people tend to upload photos or drawings to social network services (SNSs) for a better description of a specific event or to relate a story [8]. In this way, the SNS environment further facilitates connectedness among people who are otherwise separated by physical distances along with emotional exchanges with multimedia support. However, it is important to reconsider that why the *practical* modality or form of information used for describing a personal experience continues to be photo-based visual information. In this context, we propose two image types in conjunction with a physical rendering method that can provide a user with an enhanced tangible experience under the current SNS framework.

Proposed media

What are gestures for?

The use of gesture data in an HCI context is mainly based on its functionality for issuing commands. Many practical systems, such as game consoles and remote controls have actively adopted gestural input methods. However, it is true that the use of gestural information is often focused only on its functionality and not on meaning *per se*. In terms of the implied meaning of a gesture, the modality has recently started to be used to describe and log the current status of people, as the

gesture data can contain a hidden vocabulary of human day-to-day activities [5]. Considering a previous study [9], which reported that simple text-based personal messages can be saved and even considered as a gift, we assume that gestural information also can be utilized as a valuable personal medium; it can be created and experienced even in fairly meaningless contexts regardless of its functionality. From this perspective, two image types that can incorporate gesture information are proposed here.

System and data description

The proposed type of media comprises two types of 2D-code that store gesture data, i.e., a 3-DoF acceleration profile, in the form of an ordinary 2D image. For the gesture-capturing process, a commercial hand-held device, an Apple iPod touch™ was utilized. The sampling frequency used in this work was set to 50 Hz, which is sufficient to capture motion [11]. 14 paired subjects in groups of two participated in this experiment. Similar to microblog updates, the subjects were instructed to create 5 brief status updates based on both text and gestures. The gesture that should be logged for each session was defined as ‘short motion’ that can further explain or augment the corresponding text message. To preserve or not to distort the social context, each of the 7 subject groups (= 14/2) was comprised of two people who had a close relationship. During the entire session, the subjects could freely talk with their partner to maintain a relational context. However, they were visually separated so as not to affect or bias each other when creating the motion. The intention of the visual separation was to help the subjects to create a unique motion without their partner watching, which may influence the motion activity. For similar reasons, the experimenter was also

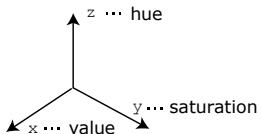

Figure 3. The gesture-color mapping rule.

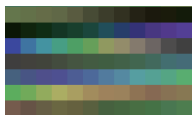

Figure 4. The cropped corresponding gesture image. Every pixel is represented in the form of square block.

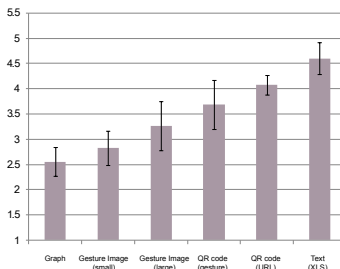

Figure 5. The mean rank of media preference. A smaller value denotes stronger user preference. Error bars represent the 95% confidence interval.

visually separated from the individuals in the groups. The measured average sampling frequency of the experiment was 49.95 Hz and the measured number of samples was 233 on average, which is approximately 4.66 sec and its 95% confidence interval is (4.40,4.93).

Proposed media

Considering that media compatibility is an important issue that affects the acceptability of a practical system, we selected the common image formats, i.e., jpg, and png, as the proposed medium platform.

- Type 1 - Gesture-based QR code

The QR code is used widely in many practical fields. The recent explosive use of hand-held devices has further increased the application area of this code. In this section, a type of QR code that can contain gesture information is proposed. The objective of the proposed gesture-based QR code is to allow general users to share their personal experience, which can be represented by gesturing, in the form of the familiar medium of a 2D image. For lossless data compression, Huffman coding, a well-known entropy-encoding algorithm, was applied before the QR code was created due to the limited capacity. After the process of entropy coding, the gesture data described in Figure 1 was compressed by 42.45%. Figure 2 illustrates examples of the proposed gesture-based QR code. Because the dense QR code could hinder one of the original purposes of the QR code, *legibility*, a type of hypermedia that only includes a URL that anchors a web page that contains the original XML data of the acceleration profiles was also proposed.

- Type 2 - RGB or HSV gesture image

The second proposed image is based on color bytes with the sequential three-axis acceleration data of the motion as shown in Figure 3. The equation below shows the mapping algorithm.

$$c_{i,j} = f(v_{i,j}), 0 \leq i \leq 2 \quad (1)$$

Here, $v_{i,j}$ is the j^{th} measured acceleration data of i^{th} axis from the mobile device, and $c_{i,j}$ is the color byte of the j^{th} pixel block.

The gesture image resembles abstract art, as shown in Figure 4. It was proposed based on the fact that a personal message can be even considered as a valuable gift [10]. In other words, the image is intended to enhance the implicit affective awareness, as addressed in previous research [6], as not as an explicit means of message transfer. With a given sampling frequency, the proposed gesture image can be translated into or can reconstruct the original motion dataset.

- Evaluation on user preference

After conducting the content creation process, each group member was instructed to experience the motion-based text data of their partner visually. The data is displayed in the form of a familiar microblog, i.e., *Twitter*. The web page, which displays the collected motion data, was anchored to the text updates in the form of a URL. External links are widely used for photos, video, and location sharing in many microblogs. As questionnaire elements, a set of media types that included an explicit graph, small and large gesture images, the gesture and the URL QR code and numeric text data were represented. A Friedman test revealed

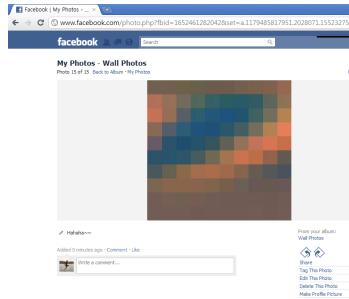

Because the proposed gesture image is compatible with an ordinary image, it can be shared through current SNSs and transferred using RSS for implicit interpersonal communication.

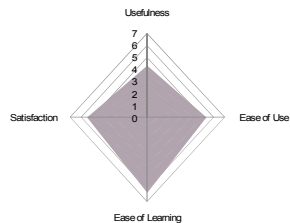

Figure 7. Result of the Usefulness, Satisfaction, and Ease of Use (USE) Questionnaire

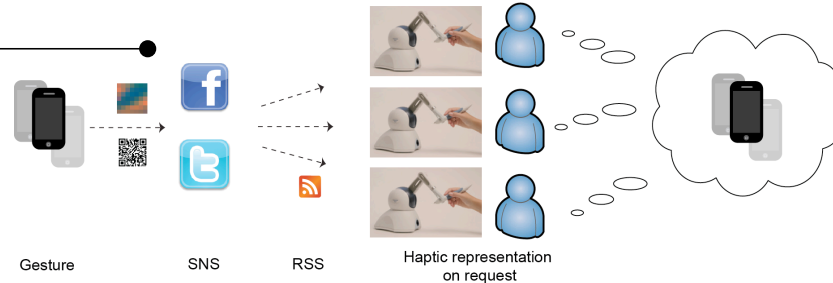

Figure 6. Physically enhanced SNS. The motion that can be shared over the SNS can be visually experienced by the interested parties. If a haptic system is available, the media is then rendered kinesthetically to enhance the social experience. This mediated communication has advantages in that it can transmit touch information, which results in provoking an emotion, even repetitively.

that there was significant differences in the ratings among the media types ($p < 0.001$, $\chi^2 = 59.4$, $df = 5$). The grouped media type also showed significant differences in the ratings ($p < 0.001$, $\chi^2 = 66.33$, $df = 3$). The subjects reported that they preferred the gestural image to the proposed QR codes mainly due to the appearance of media, as far as both types of media were intended to provide a system with gestural data. According to a preliminary self-reported test using the USE questionnaire [7], they reported no difficulties in using the proposed media on the SNS platform, as shown in Figure 7.

Multimodal representation

Because the media described in the previous section take the form of an ordinary image, it can be shared through the current platform while preserving its compatibility. However, the gesture information must be replaced with another modality if it is to be reconstructed *physically*. By defining the interaction

context as asynchronous mediated human-human interaction over the SNS platform, we could select the haptic modality as a substitution method to represent how the motion in the haptic information is exchanged in the case of direct human-human interaction, such as a handshake. Therefore, in this interaction scenario, a haptic device conveys motion information haptically *instead of* another person in an asynchronous manner. Although the rendering platform is different, the use of haptic feedback in this scenario is supported by previous researches on touch [1, 2], the findings of which revealed that a recipient of a message with haptic feedback tends to estimate the intention or emotional status of the sender. In other words, the objective of these approaches is to allow impressionistic but not exact communication. Figure 6 illustrates the architecture of tangibly enhanced SNSs. From this part, we propose a simple haptic rendering method that can be easily incorporated into a SNS. To avoid the abstract mapping issue that often arises when using 1-DoF

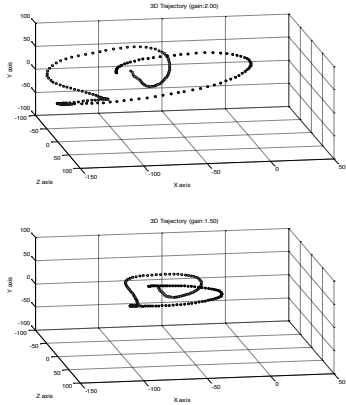

Figure 8. Example trajectories driven by the same acceleration profile with different force scaling gains

tactile feedback, kinesthetic rendering with a commercial force interface, the low-cost haptic device PHANTOM® Omni™, was utilized in this implementation. Once the gesture information is reconstructed from the proposed images, the force vector (F_i) in a Cartesian coordinate system of the i^{th} axis can be calculated on the client side as a function of the reconstructed acceleration values.

$$F_i(t) = f(\hat{v}_i(t) - \hat{v}_{m,j}(t)) \quad (2)$$

Here, $\hat{v}_i(t)$ and $\hat{v}_{m,j}(t)$ are the interpolated acceleration to ensure 1kHz haptic rendering and the corresponding mean value, respectively.

Because the mean value, which is affected by gravity force and/or draft error, can result in unintentional force bias during kinesthetic rendering, it must be removed during the calculation of the force vectors. Once the force information is determined by Eq. (2), the haptic arm then moves the user's limb, which is *passively* located on the device. Giving up the faithful copy of the *trajectory*, a specific group of people can experience the force information composed by a user. The exerted force feedback helps the user to feel or estimate the original motion. In fact, this interaction is similar to record and playback strategies in that the recorded dynamics of a specific user is unilaterally transferred and played back. The proposed gesture-to-force conversion method has another advantage in that the gesture information can be played back with scaled force and/or time. Despite the fact that force scaling is applied to numerous traditional haptic systems, the scaling in this research plays a different role in allowing a user to amplify the previously logged *free motion*.

Figure 8 shows examples of different trajectories created during passive haptic interaction in which the haptic system was driven by the reconstructed gesture data $\hat{v}_i(t)$. The intensity of every trajectory color in

Figure 8 is linearly proportional to the elapsed time. The exerted force feedback with the elapsed time induces movement of the hand in the 3-D space. The trajectory can be altered according to the grabbing force of the user.

Discussion

Although we propose two types of 2D tangible code as a practical modality to describe a personal experience, there is a limiting issue in that most ordinary users do not have high-fidelity haptic devices. To involve general users in this platform, including the experience of the haptic information, our research group is currently focusing on sensory substitution with vibrotactile feedback so that a hand-held device can be used for both persuasive authoring and as an experiencing tool. This approach, which is at an earlier stage, is based on the previous research[4] pertaining to mediated vibrotactile interaction [1-3]. Figure 9 shows an earlier implementation of the vibrotactile QR reader.

Conclusion

Tactile proximity inherently provides a user with an experience that is higher in the sense of connectedness or intimacy than explicit information. In this context, this study introduces two types of tangible media that function acceptably in the current SNS platform. In a media preference study, users agreed that the use of gestures is a type of implicit personal media which can sometimes be dedicated to a specific person. They reported no difficulties in using the proposed image in a current SNS platform, in this case the microblog

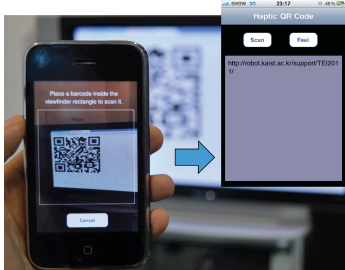

Figure 9. Example of an implemented haptic QR code reader. Once decoded, the system determines binary haptic information for vibrotactile rendering.

platform. In terms of media consumption, we describe a tangible interaction scenario over a SNS by proposing a sensory substitution method of motion data with kinesthetic feedback. As an extension of the research on mediated touch, it is expected that the proposed media and their rendering methods will enhance the tangible experience in social media spaces.

Acknowledgements

We thank Professor Don Norman for providing the inspiration and the valuable comments regarding the gesture image and its meaning in an HCI context. This work was supported by the IT R&D program of MKE/KEIT, [2009-F-048-01, Contact-free Multipoint Realistic Interaction Technology Development].

References

1. Brewster, S. and Brown, L., Tactons: structured tactile messages for non-visual information display. in, (2004), Australian Computer Society, Inc. Darlinghurst, Australia, Australia, 15-23.
2. Brown, L. and Williamson, J. Shake2Talk: Multimodal Messaging for Interpersonal Communication. *Lecture Notes in Computer Science*, 4813. 44-55.
3. Chang, A., O'Modhrain, S., Jacob, R., Gunther, E. and Ishii, H., ComTouch: design of a vibrotactile communication device. in *Designing Interactive Systems*, (2002), 312-320.
4. Han, B., Kim, S., Lim, J. and Kwon, D., One-bit Tactile Feedback Generation using Gestural Data

for Interpersonal Communication. in *The 7th International Conference on Ubiquitous Robots and Ambient Intelligence*, (2010), 362-365.

5. Hinckley, K. Input technologies and techniques. *The human-computer interaction handbook: fundamentals, evolving technologies and emerging applications*. 151-168.
6. Liechti, O. and Ichikawa, T. A digital photography framework enabling affective awareness in home communication. *Personal and Ubiquitous Computing*, 4 (1). 6-24.
7. Lund, A. Measuring usability with the USE questionnaire. *Usability and User Experience Newsletter of the STC Usability SIG*.
8. Mäkelä, A., Giller, V., Tscheligi, M. and Sefelin, R., Joking, storytelling, artsharing, expressing affection: a field trial of how children and their social network communicate with digital images in leisure time. in, (2000), ACM, 555.
9. Taylor, A. and Harper, R., Age-old practices in the 'new world': a study of gift-giving between teenage mobile phone users. in, (2002), ACM, 446.
10. Taylor, A. and Harper, R. The gift of the gab?: A design oriented sociology of young people's use of mobiles. *Computer Supported Cooperative Work (CSCW)*, 12 (3). 267-296.
11. Verplaetse, C. Inertial proprioceptive devices: Self-motion-sensing toys and tools. *IBM Systems Journal*, 35 (3). 639-650.

One-Way Pseudo Transparent Display

Andy Wu

GVU Center
Georgia Institute of Technology
TSRB, 85 5th St. NW
Atlanta, GA 30332
andywu@gatech.edu

Ali Mazalek

GVU Center
Georgia Institute of Technology
TSRB, 85 5th St. NW
Atlanta, GA 30332
mazalek@gatech.edu

Abstract

A transparent display is a display that allows people to see through it from either the front or the back. In this paper, we propose a one-way pseudo transparent display technique that allows users in front of a monitor to see through the screen.

Keywords

Tangible interaction, design, exploration, work-in-progress

ACM Classification Keywords

H5.m. Information interfaces and presentation (e.g., HCI): Miscellaneous.

General Terms

Interactive display, face tracking, space navigation

Introduction

When using a computer, a vertical display is a common device for a user to receive visual feedback from a computer. One development trend of these vertical displays is to provide a larger viewable area and a higher definition image. However, these displays create a boundary between the user and the space behind them. When the size of the display grows larger, more space is blocked as well. This limits the user's perception of the space. This project is to create a

pseudo transparent display that allows a user to see through the monitor and see the scene behind it.

Inspiration

The size of monitors has increased dramatically recently. Accordingly, the view blocked by these conventional nontransparent displays has also become larger. A transparent display links the space behind the screen with the user in front of the screen by providing a visual connection between them [6].

People are fascinated about transparent display technologies. A mature transparent display technology has not been available until the recent release of the OLED technology [7]. Yet it is still inaccessible to most people. Therefore, some people create their own *transparent desktops* on their computers (see **figure 1**). A transparent desktop is in fact a modified still desktop photograph that seamlessly connects the background scene with the computer desktop image.

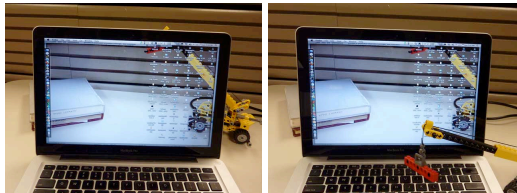

figure 1. This is a demonstration of a transparent desktop created manually. The left figure shows the objects behind the laptop as a desktop image. Oops, who moved the crane? The trick is exposed when someone moves an object away from the scene.

One can simply create a transparent desktop by taking a shot of the scene without the monitor and making it the desktop background after some photo editing. Since this desktop image is static, the user cannot see what really happens behind the screen. Furthermore, a user cannot see the spatial relationship between the two opposite sides of the screen when she moves her head.

The idea of transparent displays has been exploited in several science fiction movies using futuristic settings [1, 5, 8]. In the movie scene, users can see through the transparent display and look at objects behind it. Others can also see through the transparent display from its back and see the user's face.

Harrison et al. [3] created a pseudo-3D effect for video conferencing that provides a different spatial experience when conversing with someone. The idea is to let the user sitting in front of a video camera have the freedom to explore the space of the remote person she chats with. The video camera that transmits the image to the remote side also tracks the user's face. His setup allowed a pseudo-3D experience using only a single generic webcam at each end. Harrison also implemented a Lean and Zoom system [4] that magnifies the screen proportionally based on the user's position. Both these two projects used face tracking to process the image to be shown on the screen.

Design

The goal of this project is to create a pseudo transparent display that simulates the effect of a real transparent display. When a user moves her head to the right of the screen, she sees the left part behind the screen more. In similar fashion, she sees more of

the rear right part of the screen when she moves her head to the left. The displayed image should change when she moves forward and backward as well.

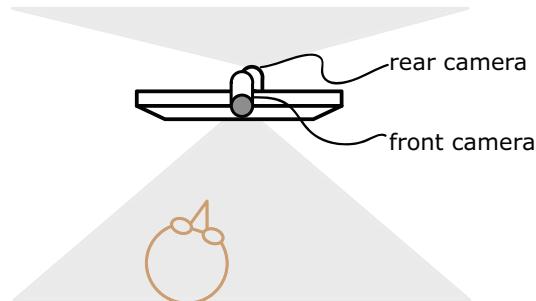

figure 2. When the user moves her head, the displayed image changes according to the position of her head. The rear camera acquires the scene behind the screen and the front camera locates the user's head.

To create the effect of a transparent display, the system has to acquire the background image and adjust the displayed image according to the position of the user's head in real-time. Therefore, a camera should be placed in front of the screen to capture the head movement of the user while a second camera with a wide-angle lens is placed in the back of the screen. The rear camera captures a high-resolution picture and crops the wanted part to show on the screen based on the user's head position. Unlike the commercial transparent displays or the displays created by special effects in science fiction movies that have two-way transparency, this project provides one-way transparency--only the user in front of the screen can see through the screen. In other words, this setup

offers better privacy to the user sitting in front of the screen than the two-way transparent display.

Implementation

This project requires heavy real-time image processing. To quickly prove this concept, the first system was developed using Quartz Composer [2], a visual programming language designed for processing and rendering graphical data. Quartz Composer can export its compositions as screen savers or native OS X applications.

The rear camera

Ideally, the rear camera has to capture a high-resolution picture of a very wide area, so that the system can crop and resize the image to be shown on the screen. Also, it needs to have a high frame rate to reflect the reality behind the screen in real-time. However, to prove the concept quickly, this system uses a webcam with that reaches 30 frames per second at a 640 x 480 resolution. To improve the view angle of the camera, a fish-eye lens with a 120-degree view angle was installed to replace the original camera lens.

Face tracking

To determine the displayed image, a front camera is used to locate the user's head in three dimensions. This prototype uses the OpenCV's Haar Cascade classifier [9] to identify and track faces. It gives the X, Y and Z positions of a user's head.

The displayed image

The displayed image is a smaller part of the original image determined by the geometric relationship between the user and the screen as shown in **figure 3**. When the user moves away from the screen, the view

angle created by her eyes and the screen is narrower. Analogously, the view angle becomes wider when she moves forward to the screen. Because the distortion of the image, the original captured image has to be calibrated before further processed.

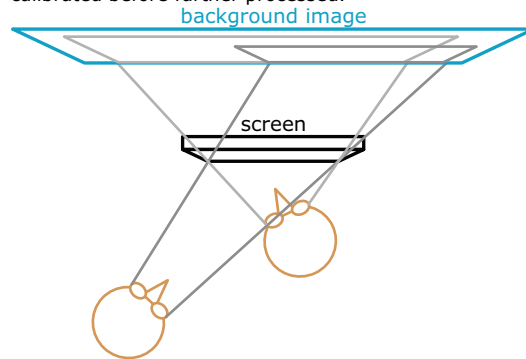

figure 3. When the user moves her head, the displayed image changes according to the position of her head.

Limitations and Challenges

Some of the limitations and issues encountered so far are worth discussing here. Most of them are because of the rear camera's limited performance and characteristics.

Recreating a 3D scene

Mapping the 3D space behind the screen to a 2D image plane loses lots of information of the real world. For example, one might see the left and right sides of a cube placed on the table by moving her head laterally. However, when this cube is placed behind the screen in our system, one can only see the side captured by the

camera (see **figure 4**). This problem is caused by the depth-difference between objects. In reality, when one moves laterally, closer objects move faster than objects in the distance. However, in this system, the displayed image is created from a rear still camera. As a result, we cannot recreate the real scene from this limited pixel information. This effect becomes a serious issue when several objects appear in the scene at different distances.

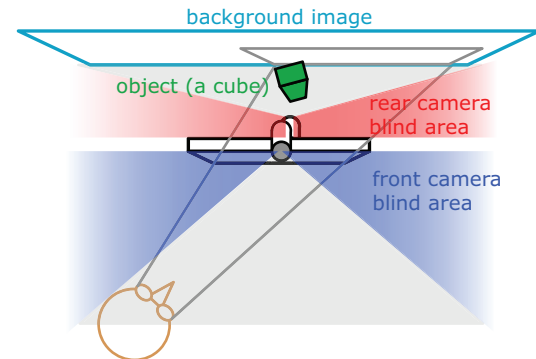

figure 4. The blue and red areas are the blind areas of the cameras. One issue of the current setup is that when the user looks at the monitor from the position shown in the figure, she expects to see the left side of the cube. However, the rear camera captures only the front facet of the cube. Therefore, the system creates an incorrect image.

Blind areas

Even though the rear camera uses a wide-angle fish-eye lens, it only captures a 120-degree view. When an object is placed right behind the screen, the camera is

either blocked by the object or cannot see the object at all. The latter condition happens often when the user grabs one side of the monitor and adjusts its angle--she cannot see her fingers at all. The front camera has a limited view as well (see **figure 4**). When the user moves far away from the camera's field of view, the system stops working.

Performance

The resolution of the camera and the computing power affect this application a lot. Since computer screens today have much higher resolutions than most cameras, to generate convincing high definition streaming images is difficult. The one-way pseudo transparent display is a concept to link the user with the space occluded by the monitor visually. Currently, the frame rate of the system is about 25 to 30 fps.

Staying focused

To obtain clear images, a camera has to stay focused on its targets. When there are multiple objects located at different distances from the camera, the camera can only focus on one of them. Hence, part of the image is blurred. On the other hand, humans' eyes, which are the most complex cameras, adjust the focal lengths quickly. Looking at multiple objects in the 3D real world is common to us. As a result, generating lifelike streaming images that can cheat our eyes is challenging.

Summary and Future Work

The one-way pseudo transparent display opens a channel to see objects behind the screen from the

user's location. It changes the displayed image according to the user's head position. It also has less privacy concerns than the commercial two-way transparent displays.

Possible improvement of the system

Several of the facing challenges and limitations are caused by the limited functionality of the rear camera. To overcome these issues, we can use two cameras to create a higher resolution stereo image and a larger field of view. This also helps solve the "missing sides" problem of a cube. Another way to resolve this issue is to use a Pan Tilt Zoom (PTZ) camera. The PTZ camera pans and tilts when the user moves laterally. It zooms when the user moves longitudinally.

The front camera has a larger blind area than the rear camera. However, in general, a user stays inside the camera view most of the time. Thus, one regular front camera should be sufficient to track the user's head movement.

Other potential applications

The proposed idea is to let users see through the screen. Yet, it has more implicit applications. This technique creates a more realistic image than a regular streaming video. Therefore, it can be used to create digital windows in rooms that do not have real windows. We can also create more realistic photographs for digital photo frames. In other words, the scene from the digital window or the photo in the digital photo frame changes according to the viewer's position.

Acknowledgements

We would like to thank members of Synaesthetic Media Lab for helping us refine the idea.

References

- [1] Cameron, J. (Dir.) (2009). Avatar. USA / UK.
- [2] Graphics & Imaging - Quartz Composer, <http://developer.apple.com/graphicsimaging/quartzcomposer/>
- [3] Harrison, C. and Dey, A. K. Lean and Zoom: Proximity-Aware User Interface and Content Magnification. In *Proceedings of the SIGCHI Conference on Human Factors in Computing Systems*. CHI '08. ACM, New York, NY, 507-510.
- [4] Harrison, C. and Hudson, S. E. 2008. Pseudo-3D Video Conferencing with a Generic Webcam. In *Proceedings of the 10th IEEE International Symposium on Multimedia*. ISM '08. IEEE, Washington, D.C., 236-241.
- [5] Hoffman, A. (Dir.) (2000). Red planet. USA / Australia.
- [6] Ishii, H. and Kobayashi, H. ClearBoard: a seamless medium for shared drawing and conversation with eye contact. In *Proceedings of the SIGCHI conference on Human factors in computing systems* (CHI '92), ACM, New York, NY, USA, 525-532.
- [7] Samsung demos 19-inch transparent AMOLED display, <http://www.engadget.com/2010/05/24/samsung-demos-19-inch-transparent-amoled-display/>
- [8] Spielberg, S. (Dir.) (2002). Minority report. USA.
- [9] Wilson, P. I. and Fernandez, J. Facial feature detection using Haar classifiers. *Journal of Computing Sciences in Colleges*. 21, 4 (Apr. 2006), 127-133.

Eco Planner: A Tabletop System for Scheduling Sustainable Routines

Augusto Esteves

Madeira Interactive Technologies
Institute
Campus da Penteada
9020-105 Funchal, Portugal
augustoeae@gmail.com

Ian Oakley

University of Madeira, Madeira
Interactive Technologies Institute
Campus da Penteada
9020-105 Funchal, Portugal
ian@uma.pt

Abstract

This paper presents Eco Planner, a tangible system that aims to encourage users to behave more sustainably. It is based on a tabletop system showing a tabular view on which users can manipulate tokens to express and observe information about their daily routines and associated consumption levels and environmental affects. It is designed to support long-term engagement through a prolonged behavior change process and support high-level group activities such as achieving sustainability goals at the level of an entire household. It argues that these qualities are valuable but poorly supported by current eco-feedback systems. This paper covers the design and implementation of Eco Planner and concludes by discussing the evaluations required to validate these claims.

Keywords

Tangible interaction, sustainability, eco-feedback.

ACM Classification Keywords

H5.m. Information interfaces and presentation (e.g., HCI): Miscellaneous.

Introduction

Energy consumption is an integral part of "the routine accomplishment of what people take to be the 'normal'

Copyright is held by the author/owner(s).

TEI'11, Work-in-Progress Workshop
Jan 23, 2011, Madeira, Portugal.



Figure 1. Two examples of ambient displays for real-time feedback on water consumption – UpStream [8] (top) and Waterbot [1] (bottom).

ways of life” [6]. Such mundane, domestic activities are directly responsible for 28% of the U.S. energy consumption [8]. Although people are increasingly concerned with the consequences of living in an unsustainable society [2], most remain unaware of the impact of their activities on the environment and of the frequency in which they engage in high-consumption behaviors [8]. One reason why everyday behavior is rarely energy-sensitive is because most users lack a sense of the amount of energy and the specific appliances they operate (apart from heating/AC). Users are typically also unaware of the nature and impact of the default configurations preset on their appliances [6]. Prior research has also indicated that habit plays a leading role in guiding energy-consumption behavior. It also suggests that altering habitual consumption practices is a key task as even slight modifications in seemingly arbitrarily but well-developed routines can substantially reduce consumption [6]. Taken together this literature suggests that users are unaware of the relationship between their behaviors/routines and their energy consumption, and that small changes to these patterns can have significant impact.

There are diverse efforts in the HCI community to leverage this situation and prompt behavior change. In particular, research on eco-feedback technology ranges widely from ambient displays ([e.g. 1, 9]) to traditional graphical interfaces ([e.g. 2, 7]). Within this space, many authors have proposed systems that sense consumption via custom electronics or smart metering systems and then promote awareness of energy and water use (e.g. see Figures 1 and 2). While it has been shown that such systems are effective in reducing consumption in the short-term [4], few are in widespread use. This paper asserts that one key reason

for this is that such devices lack the ability to keep users interested in energy-saving activities in the long term; that after an initial phase of becoming accustomed and acclimatized to the devices and feedback, users’ interest will drop and dampen and the systems will become ineffective and eventually ignored. Moreover, this paper points out that while these systems effectively and intentionally support micro-level actions, they do not deal with more meaningful higher-level goals, such as coordinated group efforts aimed towards realizing a sustainable household. These assertions are explored in the subsequent section that reviews current eco-feedback applications from the perspective of motivational theory.

The paper then moves on to present the design and implementation of Eco Planner, a tangible user interface (TUI) designed to address these issues. The motivations for this are two-fold. Firstly, this paper suggests that a tangible, physical interface may keep users’ attention and interest for longer than traditional eco-feedback systems [10]. Secondly, it argues that the persistence, accessibility and visibility of a tangible interface installed in a shared home space will be ideally suited for the coordination of sustainable activities within a household. Supporting such high level activities provides rich, diverse and relatively unexplored opportunities for realizing energy savings. This paper closes with a description of the issues that need further work prior to evaluating the Eco Planner concept in the lab and field.

Related work

Ambient displays

The WaterBot [1] and UpStream [9] systems provide users with ambient feedback regarding their water

consumption. Installed on faucets, taps and showers in users' homes they provide clear, immediate, simple and calm information relating to consumption – for example by displaying different colors (green to red) for consumptions from slight to extravagant. However, they are typically examples of ambient eco-feedback in their limited scope. For example, they do not support meaningful behavior change activities such as: (1) goal creation, commitment, and tracking; (2) comparing current performance against past performance, or the performance of others; (3) publicly committing to sustainable actions. These displays also offer no incentives or rewards for green behavior.

Graphical User Interfaces

Another prominent *eco-feedback* technology combines smart meters and interactive graphical displays ([e.g. 2, 7]). These systems normally consist of either a single sensor in the house's circuit breaker box (sometimes requiring professional installation), or several sensors distributed around the house (e.g. electric outlets, appliances). Interactive displays typically present users with complex, data heavy graphs regarding their household's consumption. Although offering more flexibility than ambient displays, these systems are similar in some ways: they typically offer little interactivity, lack incentive systems and do not attempt to support goal management or comparisons within a household. However, unlike ambient displays, such systems also fail to provide real time feedback – the displays are distant from the point of consumption. Moreover, it has been reported that when users become aware of the relatively low costs of appliance use (even with cumulative data), they can lose interest in conserving [6].

Transtheoretical model

Most *eco-feedback* applications rely on a "one-size-fits-all" solution, providing the same feedback to different individuals, with different motivations, beliefs, and attitudes towards sustainability. The transtheoretical model, however, argues that behavior change is something that occurs through five sequential stages: pre-contemplation; contemplation; preparation; action; maintenance; and relapse [3]. It suggests that the motivational cues required to support users at each stage are different. Therefore, an *eco-feedback* system intending to leverage this model needs be rich and flexible enough to offer a range of feedback as a user progresses through the stages. Few current systems attempt to achieve this level of sophistication.

Eco Planner

Eco Planner is a tangible system intended to address some of the weaknesses of current *eco-feedback* systems. Primarily, it aims to keep users motivated in sustainable actions in the long term via an engaging physical interface. Furthermore, due to the physicality and visibility of the tangible elements it aims to facilitate understanding and coordination of activity between users in a household.

Eco Planner is composed of a set of tokens and an interactive tabletop interface. Each token physically represents an activity (e.g. watching TV, doing the laundry), and users can collaboratively create their household's routine by laying the tokens on the tabletop. The 2D space of the tabletop represents a day of the week (from 7am to 11pm), so tokens placed closer to the left will represent activities completed in the morning, while tokens placed closer to the right will represent activities performed at night. Likewise,

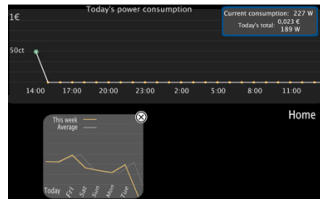
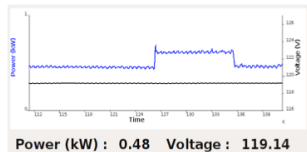

Figure 2. Graphical interfaces for two systems using *smart meters* to measure energy consumptions [2, 7].

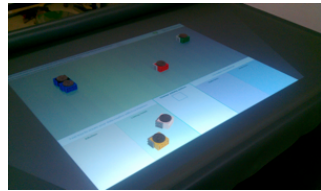

Figure 3. The Eco Planner prototype.

tokens that are vertically aligned on the tabletop represent concurrent activities. Additionally, small objects (*pyfos*) representing 30 minutes can be aggregated in front of the tokens. These are not recognized by the system, and serve only to help users create a more complete and understandable routine. Also, by placing a token on a specific area of the interface, users can access different options for the activity (e.g. with the laundry token, users can choose to commit to always do the laundry with a full tank). Users are also able to choose between ecological or financial motivational cues, changing how the system interprets their routine and the recommendations it offers. Ultimately, Eco Planner directly captures and is able to understand users' routines. It can compare them to previous routines, and display advice on alterations that would be more sustainable (or cost less). Users are also awarded green points every time they commit to a more sustainable (or cheaper) routine. These points accrue over time, serving as both a metric for comparison and as a simple reward.

Eco Planner aims to successfully motivate users in a household to be more sustainable. It was designed to:

- Avoid user inconvenience and discomfort by supported self-paced routine changes.
- Support self-comparison, as new routines can be interactively compared to previous ones.
- Allow users to set and commit to household goals during the process of producing and adjusting routines.
- Make users accountable for routines, as they are continually in view in the configuration of tabletop tokens.

- Provide nominal rewards (green points), which can be used as comparison to other households. It has been shown that users positively respond to rewards, even if they are nominal in nature [4].
- Support discussion about and eventual agreement on appliances performance, usage patterns and their impact on overall consumption. By offering detailed information and a coherent baseline, Eco Planner develops group efforts toward energy conservation [7].
- Increase awareness of energy-conserving options in products. Users often ignore visible options, instead relying on habit and split-second decisions [6]. Eco Planner informs users of specific greener options on the appliances that are part of their routine, highlighting opportunities for meaningful changes.

Applying the transtheoretical model

Eco Planner was developed with the goal of motivating users to pursue sustainable activities across all five stages of the transtheoretical model:

- **Pre-contemplation:** As users describe their normal routine on Eco Planner for the first time, they get tips on what is not sustainable, and the consequences of such behaviors.
- **Contemplation:** Users can plan for very small changes on their routine (e.g. dealing with only one activity token), encouraging them to commit to larger sustainable activities in the future [3].
- **Preparation:** Eco Planner allows users to come up with different plans for their routines, allowing them to set goals and commit to them.
- **Action:** As users engage in their new routines, Eco Planning provides them with positive reinforcement

(through green points). Moreover, by allowing for interactive exploration and on the system's interface, users may develop intrinsic motivation to behave more sustainably [3].

- **Maintenance, Relapse, Recycling:** In order for users to maintain their routines they should be, first and foremost, intrinsically motivated. The natural and engaging experience possible with tangible interaction may encourage this. Users are also able to keep track of their progress (through the accumulation of green points), which may help them reinforce and reflect on their sustainable activities and behaviors [3].

Implementation

Eco Planner was developed under the Processing environment, using the reacTIVision marker tracking technology. It's composed of tokens representing activities constructed from Lego blocks and tagged with fiducial markers, and a multi-touch interactive tabletop (which uses rear diffused illumination to track the tokens and touch controls). Currently the system works without sensing and smart-metering systems, instead relying on a knowledge base of sustainable practices to generate content. This is used to generate text-based tips on how to create more sustainable routines, as the system compares when and how the user performs certain activities to optimal versions stored in the database (e.g. comparing when users drive their cars to known traffic patterns and impact data). Eco Planner is currently a functional prototype and is undergoing user interface design iterations.

Future work

This paper argues that due to the visibility, corresponding accountability, support for collaboration and ease of physical manipulation, an application using

tangible interaction will be more likely than traditional eco-feedback technologies to motivate individuals to pursue sustainable practices. This claim is unproven and much further design, technical, and evaluation work will be required in order to validate it. This future work is discussed in the following section.

Design Issues

- The system relies on the easy manipulation of the physical tokens and on the unambiguous correspondence between them and the appliances and activities they represent. Design iterations could improve these aspects.
- The system models household routines. An important design improvement would be to support the mapping of particular activities to particular users.

Technical Issues

- Eco Planner currently offers day-by-day routine creation and visualization. Recent systems that can actuate token positions on a tabletop offer the potential of storing different routines for different week-days [5].
- Increase and validate the data on sustainable practices in the knowledge database.
- Incorporate sensing devices and smart metering systems so that discrepancies between the users' routines on the system and the reality of consumption can be compared.

Evaluation Issues

Eco Planner will need to be evaluated in both the lab and the field. Due to the size, cost and complexity of the system, lab studies are much simpler to execute

than field deployments. Lab studies will also allow many of the basic system features to be tested and refined in a rapid cycle, but will lack the ecological validity of field evaluations. In contrast, deployments will take the form of 2-3 month case studies of individual families [e.g. 10]. Metrics will include quantitative measures of consumption and frequency of system interaction, subjective measures of attitudes and perceived performance and qualitative measures of how the system is used. This last category will explore the suitability of the application to coordinate sustainable actions within a household and the ability to keep users invested in sustainable activities for long periods of time. It will also consider how people use the tokens outside of the tabletop interface (e.g. handing tokens to members of the household to attribute responsibility over a specific task, leaving tokens around appliances to serve as reminders of commitments or goals) – such unexpected interactions are one of advantages of tangible interaction over other approaches to eco-feedback.

Conclusion

Eco Planner allows users to visualize and compare the impact of their daily routines on the environment, ultimately aiming to encourage more sustainable practices. This paper argues that, compared to other eco-feedback systems, a TUI might better maintain users' motivation over long time periods. Tangible interaction may also effectively coordinate sustainable activities within a household. In order to validate these claims a series of users studies and evaluations is planned. We anticipate that the results of these studies will be a valuable addition to HCI research in the domain of sustainability and serves as a meaningful new domain in which to investigate tangible interaction.

References

- [1] Ernesto Arroyo, Leonardo Bonanni, and Ted Selker. 2005. Waterbot: exploring feedback and persuasive techniques at the sink. In CHI '05. ACM, NY, 631-639.
- [2] Filipe Quintal, Nuno J. Nunes, Adrian Ocneanu, and Mario Berges. 2010. SINAIS: home consumption package: a low-cost eco-feedback energy-monitoring research platform. In DIS '10. ACM, NY, 419-421.
- [3] Helen Ai He, Saul Greenberg, and Elaine M. Huang. 2010. One size does not fit all: applying the transtheoretical model to energy feedback technology design. In CHI '10. ACM, NY, 927-936.
- [4] Jon Froehlich, Leah Findlater, and James Landay. 2010. The design of eco-feedback technology. In CHI '10. ACM, NY, 927-936.
- [5] Malte Weiss. Bringing everyday applications to interactive surfaces. In Adjunct proceedings of UIST '10, ACM, NY.
- [6] Pierce, J., Schiano, D., Paulos, E. (2010) "Home, Habits, and Energy: Examining Domestic Interactions and Energy Consumption." In CHI '10. ACM, NY.
- [7] Riche, Y., Dodge, J., and Metoyer, R. A. 2010. "Studying always-on electricity feedback in the home". In CHI '10. ACM, NY.
- [8] Shwetak N. Patel, Sidhant Gupta, and Matthew S. Reynolds. 2010. The design and evaluation of an end-user-deployable, whole house, contactless power consumption sensor. In CHI '10. ACM, NY.
- [9] Stacey Kuznetsov and Eric Paulos. 2010. UpStream: motivating water conservation with low-cost water flow sensing and persuasive displays. In CHI '10. ACM, NY, 927-936.
- [10] William W. Gaver, John Bowers, Andrew Boucher, Hans Gellerson, Sarah Pennington, Albrecht Schmidt, Anthony Steed, Nicholas Villars, and Brendan Walker. 2004. The drift table: designing for ludic engagement. In CHI '04 extended abstracts on Human factors in computing systems (CHI '04).

Virtual Mouse: A Low Cost Proximity-based Gestural Pointing Device

Sheng Kai Tang

ASUS Design Center
ASUSTeK COMPUTER, Inc.
15, Li-Te Rd., Peitou,
Taipei 112, Taiwan
tony1_tang@asus.com

Wen Chieh Tseng

ASUS Design Center
ASUSTeK COMPUTER, Inc.
15, Li-Te Rd., Peitou,
Taipei 112, Taiwan
parks_tzeng@asus.com

Kuo Chung Chiu

ASUS Design Center
ASUSTeK COMPUTER, Inc.
15, Li-Te Rd., Peitou,
Taipei 112, Taiwan
patrick_chiu@asus.com

Wei Wen Luo

ASUS Design Center
ASUSTeK COMPUTER, Inc.
15, Li-Te Rd., Peitou,
Taipei 112, Taiwan
hunter_luo@asus.com

Sheng Ta Lin

ASUS Design Center
ASUSTeK COMPUTER, Inc.
15, Li-Te Rd., Peitou,
Taipei 112, Taiwan
ted1_lin@asus.com

Yen Ping Liu

ASUS Design Center
ASUSTeK COMPUTER, Inc.
15, Li-Te Rd., Peitou,
Taipei 112, Taiwan
ping1_liu@asus.com

Abstract

Effectively addressing the portability of a computer mouse has motivated researchers to generate diverse solutions. Eliminating the constraints of mouse form factor by adopting vision-based techniques has recognized as an effective approach. However, current solutions cost significant computing power and require additional learning, thus making them inapplicable in industry. This work presents the Virtual Mouse, a low-cost proximity-based pointing device, consisting of 10 IR transceivers, a multiplexer, a microcontroller and pattern recognition rules. With this embedded device on the side of a laptop computer, a user can drive the cursor and activate related mouse events intuitively. Preliminary testing results prove the feasibility, and issues are also reported for future improvements.

Keywords

Proximity based device, IR sensor, pointing device, virtual mouse.

ACM Classification Keywords

H5.m. Information interfaces and presentation (e.g., HCI): Miscellaneous.

Copyright is held by the author/owner(s).
TEI'11, Work-in-Progress Workshop
Jan 23, 2011, Madeira, Portugal.

Introduction

According to statistics of the International Data Corporation (IDC), the global consumption of laptop computers has passed the "Gold Cross" for the first time, exceeding that of desktop computer in 2010. This phenomenon reflects the importance of "portability" among computer users [2][3].

However, in addition to a touch pad or a track point already embedded in a laptop computer supporting pointing tasks, carrying an additional pointing device, i.e. a full size computer mouse, to enhance performance and ergonomics is inevitable and inconvenient. This additional device is owing to that the event structure of a touch pad or a track point requires two fingers, mostly a thumb and a forefinger, acting awkwardly to activate a drag action or a drag-selection action; meanwhile, that of a computer mouse needs only one finger to activate such action. This feature lowers the efficiency and comfort of a touch pad or a track point over those of a conventional computer mouse.

Effectively addressing the portability of a computer mouse has motivated industrial designers to flatten a computer mouse for easy carry [2] and even to slot into the laptop body while not in use [3]. Conversely, computer scientists create a computer mouse without a physical body to achieve ubiquitous computing. These invisible mice can translate hand gestures and movements into mouse events by using computer cameras as a signal input [1][5][6][7].

Still, those inflatable mice can not fulfill the ergonomic requirement of intensive operations. In contrast, despite eliminating concern over ergonomic constraints,

vision-based approaches expend a significant amount of computing power, i.e. equal to almost a high performance GPU, to recognize predefined hand gestures, which increases the mental load of user, thus making these solutions inapplicable in industry.

This work, describes a novel proximity-based pointing device consisting of 10 pairs of inexpensive infrared transceivers, a multiplexer, a microcontroller and a pattern recognition algorithm. This embedded device on the side of a laptop computer detects the intuitive hand-movements of users on the tabletop and further translates them into mouse movements and events (Fig. 1). Equipped with full mouse functions without a physical mouse body, the proposed device is referred to as a Virtual Mouse, similar to terminology used in previous works.

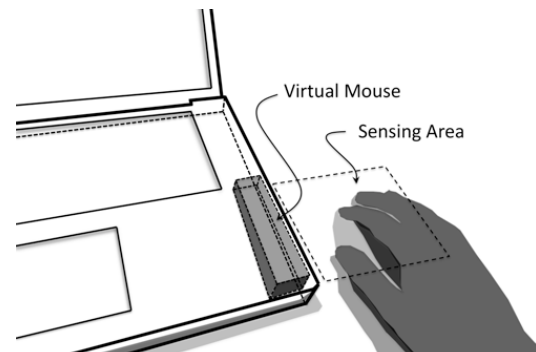

figure 1. Concept of Virtual Mouse.

Implementation

Cost Savings Infrared Transceiver

The arrangement of transmitter and receiver for an infrared (IR) transceiver, i.e. a well-developed device in the market, allows it to detect an object and determine the distances to it accurately. IR transceiver is thus extensively adopted as a reliable input device in security, robotics and home automation.

Rather than purchasing these mature products ranging from US\$ 30 to 100 or even more expensive ones designed for specific purposes, researchers without an electronic engineering background can still easily assemble components to construct an IR transceiver in order to resolve diverse laboratory problems and explore new sensing possibilities. Therefore, this work presents a simple IR transceiver rapidly by using only an IR LED, phototransistor, capacitor and two resistors, which cumulatively cost less than US\$ 0.5.

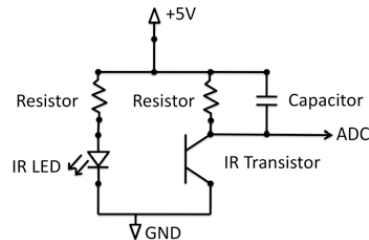

figure 2. Circuit scheme of homemade IR transceiver.

Specifically, a 3mm IR LED is powered through a 330-Ohm resistor, while a 3mm phototransistor is powered through a 20K-Ohm resistor with 5-Volt DC power

supply. Additionally, the Base pin of the phototransistor is connected to an additional 0.1u capacitor for stabilization. The Base pin allows us to acquire linear signals within 6cm range, which is sufficient for our Virtual Mouse prototype (Fig. 2).

Infrared Transceiver Bar

The customized IR transceiver provides a one-dimensional sensing ability. Combining 10 identical IR transceivers and arranging them in parallel allow us to create a device capable of detecting objects on a 4cm * 6cm two-dimensional plane. The shape of an object or its movement can be recognized after analyzing the sensor signals. Restated, this customized device is nearly equal to a touch pad that enables finger touch and gesture recognition.

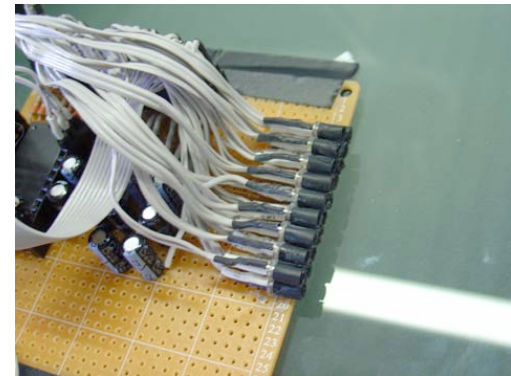

figure 3. Prototype of IR sensor bar.

Ten IR transceivers require a prohibitively expensive 10 analog input-pins of a microcontroller to read signals,

explaining why the proposed device uses a multiplexer (MUX) as a digital switch to reduce the number of input pins. Therefore, 10 transceivers are connected to the MUX and the MUX is connected to a microcontroller as a de-multiplexer (Fig. 3).

Pattern Recognition

Based on 10 IR transceiver signals, this work also develops sequential rules to recognize diverse signal patterns, which are fundamental to driving a mouse cursor and triggering corresponding events by hand, i.e. button down, button up, click, double click. In contrast with training models to achieve a high performance directly, this set of rules originates from observation of invited users and is intended mainly for rapid proof of concept to facilitate the future development involved in additional resources, e.g., software and firmware engineers.

Ten subjects, i.e. 5 male and 5 female, were invited to collect hand gesture patterns. Subjects were instructed to perform 6 actions within the sensing area, i.e. vertical move, horizontal move, diagonal move, forefinger click, forefinger double click and middle-finger click. Sensor signals were further recorded and analyzed.

Eventually, 4 rules derived from the previous 6 testing actions are placement, forefinger-up, middle-finger-up and move. A pattern in which the signal pattern is divided into two stages and the stage values subsequently decrease is recognized as placement, implying that the middle finger and forefinger appear in the sensing area (Fig. 4-a). A pattern in which the value of the second stage increases and exceeds that of the first stage is recognized as forefinger up (Fig. 4-b).

If the value of first stage increases and exceeds that of the placement pattern, this pattern is recognized as middle finger up (Fig. 4-c). A pattern in which the value of second stage changes horizontally or moves vertically (or both) in comparison with that of the previous pattern is interpreted as move (Fig. 4-d).

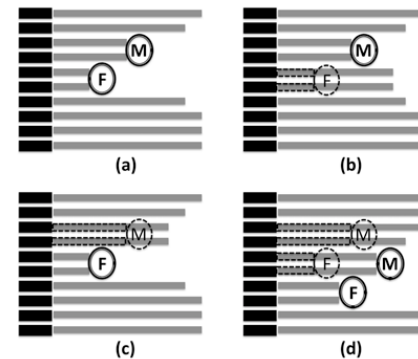

figure 4. Pattern recognition rules.

Finite State Machine

Based on the above rules, a finite state machine (FSM) is designed to interpret hand gestures and trigger their corresponding mouse events. Consider a drag action, in which a touch pad or a track point requires two fingers to activate. The proposed FSM begins with the non-detection state (N). While the placement pattern is recognized, the FSM moves to ready state (R). While the forefinger-up pattern and placement are subsequently detected within 100 milliseconds, the FSM moves to left-button-down state (LBD) and triggers the left-button-down event. Notably, the FSM goes to ready

state (R) again if no new pattern is detected within 300 milliseconds. At this moment, while the move pattern is recognized, the FSM moves to new position state (NP) and triggers new X-Y coordinate event. While forefinger-up is detected, the FSM moves to left-button-up state (LBU) and triggers the left-button-up event. Once the placement is recognized, the FSM returns to ready state (R). Rather than using a computer mouse, the above sequence completes a drag action with hand and our Virtual Mouse (Fig. 5).

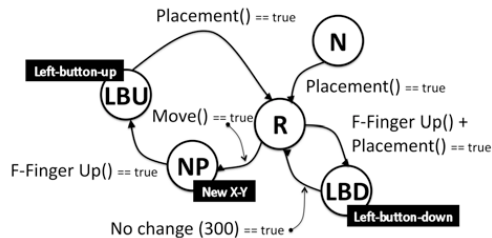

figure 5. Finite state machine for drag action.

Preliminary Testing

Ten subjects invited for a previous observation used the virtual mouse again to complete tasks in a 480px * 360px simulation window. The simulation window has three 40px * 40px squares: one is blue, another is red and the other is transparent with a dashed outline. Subjects were requested to click and double click the red square and, then, drag the blue square to the transparent square sequentially 10 times. Subject performances were recorded for later analysis.

Analytical results indicate that the average completion rate of a click (84%) is higher than that of a double click (70%) (Fig. 6). Specifically, incomplete tasks initially occur several times, a phenomenon attributed to the required learning period. A double click has a 300 milliseconds time constraint making it more difficult to get used to than with a single click and also requiring a longer time to learn.

Our results further demonstrate that the total average completion rate of a click (77%), single plus double, surpasses that of a drag (70%) (Fig. 6). Given the lack of a specific trend on the charts, subjects were interviewed to identify potential reasons. Most subjects indicated that the sensing area of the Virtual Mouse prototype is insufficiently large. Their finger were thus always out of boundary when dragging; in addition, the FSM lost signals before the controlled square could reach the target area.

	Female					Male					AVG
	S1	S2	S3	S4	S5	S6	S7	S8	S9	S10	
Click	8	7	8	9	8	9	8	9	9	9	84%
Double Click	6	6	7	7	7	8	7	6	8	8	70%
Drag	8	8	9	7	7	6	7	7	6	7	72%

figure 6. Statistic result of preliminary user testing.

Potential applications

With this IR transceiver bar, two of them can be embedded at two sides of a laptop computer. For ordinary mouse functions, a right hand/left hand (according to user's handedness) can easily drive the cursor and trigger events (Fig. 7-a). While using two

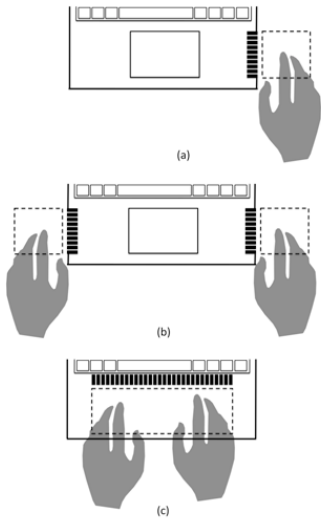

figure 7. Potential applications.

hands simultaneously for manipulation, a user can achieve scale and rotation, which resemble those of a multi-touch pad and display (Fig. 7-b).

A longer IR bar can also be embedded at the upper edge of a palm rest, which sends IR signals to the lower edge of the palm rest and turns it into a sensible surface. A user can perform all actions described above freely on the palm rest. Importantly, no additional plane area outside the laptop is required for operation, thus making the Virtual Mouse applicable under all circumstances (Fig. 7-c).

Conclusion and future study

The Virtual Mouse has received considerable attention in both academic and industrial communities. Rather than focusing on a novel concept, the proposed Virtual Mouse prototype provides a cost-savings approach for mass production. Replacing the common vision-based scheme with an inexpensive IR sensor bar has cumulatively reduced the cost from \$US 50 to \$US 5.

Instead of adopting predefined gestures to activate mouse functions, emulating the intuitive finger gestures of conventional mouse to eliminate the learning curve is another benefit of this work. Unlike a camera collecting complicated imagery data for whole-hand gestures, our homemade IR sensor bar allows us to acquire adequate signals for subtle finger gestures.

Although issues such as increasing the smoothness and enlarging the sensing area require further improvement, this work significantly contributes to efforts to demonstrate the feasibility of a potential solution and develop technical specifications.

In addition to replacing the 3mm LED with a SMD one to increase the resolution and enlarge the sensing area, efforts are underway in our laboratory to modify the pattern recognition rules and link the signal to the operation system. Additional developmental results and evaluations will be published in the near future.

References

- [1] Gai, Y., Wang, H. and Wang, K. A virtual mouse system for mobile device. In Proceedings of the 4th international conference on Mobile and ubiquitous multimedia. ACM Press (2005), 127 - 131.
- [2] Jelly Click , http://www.designodoubt.com/entry/Jelly-click_-_mouse-for-laptop
- [3] Kim, S., Kim, H., Lee, B., Nam, T., and Lee, W. Inflatable mouse: volume-adjustable mouse with air-pressure-sensitive input and haptic feedback. In Proceedings of CHI '08. ACM Press (2008), 211-224.
- [4] Polacek, O. and Mikovec, Z. Hands free mouse: comparative study on mouse clicks controlled by humming. In Proceedings of CHI' 10. ACM Press (2010), 3769-3774.
- [5] Robertson, P., Laddaga, R. and Kleek, M.V. Virtual mouse vision based interface. In Proceedings of the 9th international conference on Intelligent user interfaces. ACM Press (2004), 177-183.
- [6] Shahzad M. and Laszlo, J. Visual touchpad: a two-handed gestural input device. In Proceedings of the 6th international conference on Multimodal interfaces. ACM Press (2004), 289-296.
- [7] Zhang, Z., Wu, Y., Shan, Y. and Shafer, S. Visual panel: virtual mouse, keyboard and 3D controller with an ordinary piece of paper. In Proceedings of the 2001 Perceptive user interfaces, ACM Press (2001), 1-8.

Entangling Ambient Information with Peripheral Interaction

Doris Hausen

University of Munich
Amalienstraße 17
80333 Munich, Germany
doris.hausen@ifi.lmu.de

Andreas Butz

University of Munich
Amalienstraße 17
80333 Munich, Germany
andreas.butz@ifi.lmu.de

Abstract

Ambient information systems have been an active research area since the 1990s. However, most of these ambient systems let the user only passively consume information, and do not provide a way to interact with it. In this paper, we offer a view beyond just representing information. We propose to engage the user in a peripheral interaction with the ambient device. By keeping it peripheral, all advantages of ambient information systems – e.g. keeping the users aware without burdening them – are preserved. We will demonstrate this concept with two prototypes: an ambient appointment projection and a presence-indicating tangible.

Keywords

Ambient information, peripheral interaction

ACM Classification Keywords

H5.m. [Information interfaces and presentation]: Miscellaneous

General Terms

Design, Experimentation, Human Factors

Introduction

In the non-digital world, ambient information can be found everywhere. The light, which comes through the window, offers information about the time and weather. Body language gives us hints about the feelings of oth-

ers. People walking in the hallway provide us with auditory feedback about the activity in our surrounding environment. We consume and interpret all this information without focusing our attention on it.

Digital ambient information, which might be collected by sensors, can have a number of advantages: Concerning the capturing of information, hardware sensors can be more sensitive than the human perception. Furthermore, information can be collected in places, in which the user is not present and therefore would not be able to absorb it. Consequently, information of various sensors from various places can be combined and interpreted and therefore provide more elaborate information. Above all, this information can be stored and made available whenever needed. In general, digital ambient information consists of only few pieces of non-critical information and often is presented in an abstract way [4].

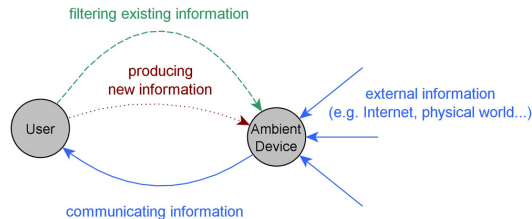

figure 1. The interplay of a user and a digital ambient device
The basic interplay between the user and the ambient device is depicted in figure 1 (solid blue lines). One or more external sources are communicated to the user through the ambient device. The user in this case is a passive consumer.

Going beyond this basic presentation of information, we need to take the users and their actions into account. This paper presents the first steps towards this goal by offering a classification and briefly introducing two prototypes which combine ambient information with peripheral interaction.

Related Work

A good overview of ambient information systems is offered by Pousman and Stasko [4] who also present a taxonomy. They depict four design dimensions: Information capacity (amount of information), notification level (degree of interruption), representation of fidelity (way of displaying the information ranging from direct to very abstract) and aesthetic emphasis (importance of aesthetics).

The interplay of interaction and ambient information has been taken into account by different research groups. Streit et al. [7], Vogel et al. [8] and Ryu et al. [5] present ambient displays, which offer interaction prospects to the user. All three define different interaction zones in the vicinity of a display ranging from ambient and implicit interaction to explicit interaction. Depending on the zone the user is standing in, the displays offer more detailed information up to personal and private data. In all three cases the user is augmented with small gadgets, such as an air mouse or RFID tags.

Darren Edge proposed peripheral tangible interaction [1, 2], which he defined as "episodic engagement with tangibles, in which users perform fast, frequent interactions with physical objects on the periphery of their workspace, to create, inspect and update digital infor-

mation which otherwise resides on the periphery of their attention" [2].

Beyond Basic Representation of Information

As shown in figure 1 (dotted red and dashed green), the users can interact in two different ways: On the one hand, they can produce new information (dotted red) – e.g. about their current situation – by their actions, which the ambient device then can communicate. It is possible to combine information of several users or external information. A typical example for this case is presence information. On the other hand, an ambient device can react to user input by filtering the already available content without changing the overall available information (dashed green). One example is recognizing a nearby user and offering personalized information for this particular user.

The interplay (figure 1) of the users, their actions and the ambient information can be further divided into more detailed categories.

Producing New Information

Figure 2 shows different possibilities for the user to produce more information, which can then be shown in an ambient way. Most importantly, the interaction of the user can be broken up into implicit and explicit interaction. Implicit interaction is defined as "an action performed by the user that is not primarily aimed to interact with a computerized system but which such a system understands as input" [6] and usually collected by sensors. Using explicit interaction, the user is actively putting information into the ambient system, e.g. by manipulation of the device itself or entering data via a PC or a website. Life logging can be placed in this

space and can comprise elements of implicit and explicit interaction.

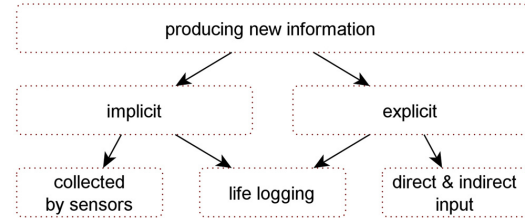

figure 2. Ways of information production by the user.

Filtering Existing Information

Another form of interplay between ambient information and the user is filtering existing and available information as depicted in figure 3. In this case, there is no new information generated by the user's actions, but only the view is adapted, e.g. further details or even private data is available on demand. Once again, the user can either be offered an adapted view by implicit interaction (e.g. coming closer) or by explicit interaction (e.g. executing a predefined gesture or turning the device).

Concerning both types of interaction, one very important fact always has to be kept in mind: The key feature of ambient information is to offer additional information to the users without further burdening them. The same requirement has to be imposed on the interaction with such a system. Consequently, interaction with an ambient information system needs to be casual and peripheral.

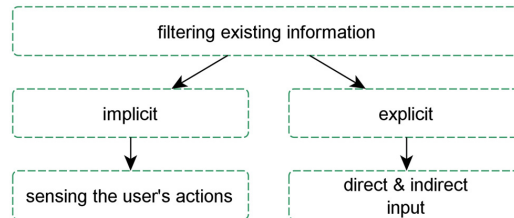

figure 3. Ways in which the user can filter information and adapt the view of the ambient device.

Often, information which is not relevant to the main task is presented next or even above the currently important data and interrupts the current workflow, but in return offers interaction possibilities. By moving this kind of information to the periphery and offering ways to interact with it in a non-focused way (e.g. by performing a simple gesture) will help the user not to move the focal attention away from the main task, but still react to other information. We expect that this will lead to fewer interruptions and less attention shifts.

Granularity of Interaction

Different input mechanisms – especially for explicit peripheral interaction – can be imagined. A glance at an object or display or a region somewhere in the users’ vicinity can be understood as input to the system. On the other hand, a casual gesture, such as wiping can be interpreted. Even more detailed hand gestures can still be peripheral. Speech input as well as direct manipulation of a digital or tangible object can also be imagined.

These input mechanisms differ in granularity and therefore they are able to encode a diverse number of commands. Very casual input, such as the wiping gesture

mentioned above, will only offer few options, e.g. wiping towards the user and wiping away from the user, while a precise hand gesture, possibly tracked by a touch sensitive surface, could offer a much wider variety of options.

Nonetheless, for peripheral interaction, it can be expected that in most cases there is no need for many commands.

Additional Characteristics

Another characteristic of ambient information systems and peripheral interaction is the distinction between public and private information (and therefore interaction). Speech input, for example, can easily be overheard by others while small and therefore rather precise gestures are harder to be recognized by others. Interaction can be close by or rather far away, e.g. input on a touch sensitive surface at ones desk or input via a glance at an object a few meters away.

First Two Prototypes

To verify these ideas, we are planning to build a series of experimental prototypes. This, of course, also means to deal with the aesthetic and comprehensive design of ambient user interfaces. Anyhow the main focus will be on the interaction, which should be as self-explanatory as possible and be executed in a peripheral way.

Ambient Appointment Projection

With this first prototype, we propose an ambient visualization projected next to the user’s keyboard (see figure 4) as a basic overview of all upcoming events and a reminder of close events. Users can acquire more details about an appointment whenever they want to.

Consequently, this prototype incorporates interaction by explicitly filtering information. Acquiring additional information is realized by a camera tracked casual hand gesture. Wiping towards the user will offer more details about an event as a balloon tip on the user's screen, while wiping away will snooze a reminder animation (e.g. a pulsating sphere of the spiral) of an upcoming appointment.



figure 4. A projector and a web cam are mounted over a desk for ambient projection and peripheral interaction.

We verified the balance between notification and distraction in a user study. Twelve participants were asked to type a given text as fast and correct as possible while not missing any appointments. We found that our ambient interface, compared to state of the art reminders, e.g. the one provided by Outlook, offers sufficient awareness, while handling appointments smoother by less disruptive reminders, which require a wiping gesture for details about the appointment in question.

Tangible Presence Indication

The second prototype communicates presence information of the user and colleagues or friends.

An Arduino¹ controlled tube consisting of several separate levels is placed on the user's desk. The upmost and biggest level (see figure 5) represents the availability of the tube's owner. By turning this level by hand (see figure 5 on the right) different status can be set (similar to instant messaging status like "available", "away", "do not disturb", but also more detailed options like "in a meeting" are supported and represented in a color coded way), by pushing down the upmost level, which integrates a button, the users can set the approximate time they will be in this status (indicated by the luminance of the level). Consequently, this prototype offers the user the possibility to explicitly produce new information.

All lower levels represent selected colleagues. The whole system is connected to Skype, so that it can be used with others who might not have such a tangible.



figure 5. A tangible representing presence information of the users and their colleagues. It also offers manipulation of one's status by turning and pushing down the top.

Before building the object, a survey with 46 participants was carried out to meet the requirements of the users. In general, this system is intended to be used in

¹ <http://www.arduino.cc>

an office and improve communication and lessen unwanted interruptions by offering an easy peripheral input method and therefore encourage more accurate presence information.

A long-term evaluation is currently being planned. For this purpose, two equal prototypes have been built.

Conclusion and Future Steps

The prototypes above denote a first step into the research of adding peripheral interaction to ambient information systems. They both act as one example for the two basic categories “producing new information” and “filtering existing information”. The appointment projection was already tested in a lab study and proved to be equally effective in keeping the user aware of appointments. At the same time, it reduces displeasing interruptions and therefore is more convenient for the user. The tangible presence indication tube was built according to survey results. A long-term evaluation is currently being prepared.

To cover the whole spectrum of the classification depicted in figure 2 and 3, we will build more prototypes. They will also vary in granularity of interaction. When evaluating them, one has to keep in mind that the benefit of those systems often cannot be highlighted in a short, lab-based user study. This is due to the fact that they usually do not act as primary task, and therefore a long-term study is more suited. Another possibility, which is applied to ambient information systems, is

a heuristic evaluation based on the findings of Mankoff et al. [3], who adapted Nielsen’s heuristics to the special needs of ambient displays. Nonetheless, these heuristics do not include peripheral interaction. Consequently new evaluation methods need to be discussed.

References

- [1] Edge, D., and Blackwell, A.F. Peripheral tangible interaction by analytic design. *TEI*, (2009), 69-76.
- [2] Edge, D. Tangible User Interfaces for Peripheral Interaction. *Technical Report*, (2008).
- [3] Mankoff J., Dey, A. K., Hsieh, G., Kientz, J., Lederer, S. and Ames, M. Heuristic Evaluation of Ambient Displays. *CHI*, (2003), 169-176
- [4] Pousman, Z., and Stasko, J. A Taxonomy of Ambient Information Systems : Four Patterns of Design. *Advanced Visual Interfaces*, (2006), 67-74.
- [5] Ryu, H., Yoon, Y., Lim, M., Park, C., Park, S., and Choi, S. Picture navigation using an ambient display and implicit interactions. *OZCHI*, (2007), 223-226
- [6] Schmidt, A. Implicit human computer interaction through context. *Personal Technologies*, (2000), 191-199.
- [7] Streitz, N., Röcker, C., Prante, T., Stenzel, R., and van Alphen, D. Situated Interaction with Ambient Information: Facilitating Awareness and Communication in Ubiquitous Work Environments. *HCI International*, (2003), 133-137.
- [8] Vogel, D., and Balakrishnan, R. Interactive Public Ambient Displays: Transitioning from Implicit to Explicit, Public to Personal, Interaction with Multiple Users. *UIST*, (2004), 137-146.

Tangible User Interface for Architectural Modeling and Analyses

Chih-Pin Hsiao

College of Architecture
Georgia Institute of Technology
Atlanta, Georgia 30332
chsiao9@gatech.edu

Ellen Yi-Luen Do

College of Architecture
Georgia Institute of Technology
Atlanta, Georgia 30332
ellendo@gatech.edu

Brian R. Johnson

Design Machine Group
College of Built Environment
University of Washington
Seattle, Washington 98105
brj@uw.edu

Abstract

We present a prototype system called TUI-AMA to support the common physical cardboard model building behavior in the early architectural design stage. The system uses computer vision technique to scan cardboard pieces and turns them into digital shapes in the virtual environment. Each cardboard piece has a marker to help the system identify its location and scale. The system projects simulation images of environmental impacts for architects to see them right on their physical models instead of a computer screen. With TUI-AMA, architects can benefit from both the digital simulation and the physical model making in their design process.

Keywords

Tangible User Interfaces, Spatial Augmented Reality, Architectural Design

ACM Classification Keywords

H.5.2 User Interface: Haptic I/O

General Terms

Design, Experimentation

Copyright is held by the author/owner(s).

TEI'11, Work-in-Progress Workshop

Jan 23, 2011, Madeira, Portugal.

Introduction and Background

Architectural design is an activity with heavy cognitive load, involving tactile, spatial and auditory perceptions. Among these, the most important one is the spatial perception. Especially in the early design stage, architects often construct physical cardboard models to visualize their designs before making 3D CAD models and running them through simulation tools to assess environmental impacts (e.g., sun, wind, thermal effects, etc.). There are two issues with this common practice: (1) they need to switch between digital and physical platforms in order to access the simulation information; (2) the current physical modeling environment doesn't provide any support for the computer simulation.

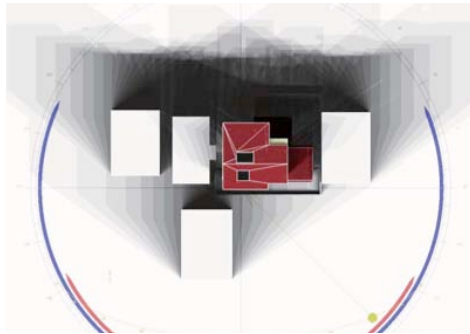

figure 1. Stereographic diagram in a particular date of a year

Between Digital and Physical Platforms

Architects use physical models to explore spaces and forms. They also use simulation tools for lighting simulation, sun patch and shadow simulation, thermal simulation, and visibility. Figure 1 shows a simple

simulation example of shadow stereographic diagram that architects may use during the design process. This diagram gives architects a clear understanding of the dark area around the site. However, this simulation task is hardly achieved in a pure physical world. Thus, simulation tools require digital models as input. Architects have to spend time making CAD drawings of their models before they can engage the simulation tools to check their designs. Wouldn't it be nice if we can bring simulation results onto the table, to the physical cardboard modeling they are making? Binder et al. argue, "Designers in architectural studios, both in education and practice, have worked to integrate digital and physical media ever since they began to utilize digital tools in the design process" [3].

Lack of Embedded Information in the Physical Model

After architects finish building their physical model, they may choose to either use CAD tools to construct the model from scratch on a computer or to digitize it with a 3D scanner. The scanners only produce geometry data, such as point cloud, instead of meaningful objects. For instance, a wall object becomes a collection of coordinates in the digital format and it needs to be defined as an object before a computer can process simulation. Therefore, both scanning physical models and constructing digital models using CAD require significant efforts to translate geometry data into useful building information data.

Related Work

Tangible User Interfaces (TUIs) are increasingly gaining popularity. Researchers had demonstrated the use of TUI in urban and landscape planning settings. In *Urp* project, Underkoffler et al. brought the computer simulation power to the luminous desktop for urban planner to study their design [6]. Through manipulating the tangible objects, planners could obtain more

information from the projected two-dimensional display of various simulations to assist them in design decision making. *Illuminating Clay* extended the previous project by scanning 3-dimensional objects in real-time and projecting associated simulation images back to the landscape model [4]. Designers could see the simulation results in real-time after modifying the three-dimensional clay model.

There are also some examples for studying architectural models by using TUIs. *Dynamic Shader Lamps* is a great example of studying materials and making annotations [1]. The projecting virtual images on the surface of physical models enabled users, even nonprofessionals, to be able to edit materials at ease. Instead of using projecting image, Song et al. use digital pen for recording annotation and editing geometry in both physical and digital world [5]. Belcher et al. built an Augmented Reality application with tangible tools to enhance the communication, visualization, and simulation in design activities [2].

Scenario

Cardboard models are commonly used in the conceptual design stage. Architects can trim or replace parts in order to study alternative shapes. To help architects move seamlessly between the digital and the physical platforms, our software system needs to know the shape, the location, and the orientation of the cardboard pieces. We adopted a computer vision strategy to work with almost any type of cardboard, permit re-shaping of pieces, and minimize instrumentation costs (as compared to processing time) while producing a practical system. We used a two-step process combining an edge detection algorithm (to define the shapes from individual pieces of cardboard), and marker tracking software to detect their location and orientation in the model.

In this process every piece of cardboard needs to have a unique marker on it. Since model pieces are usually cut flat in the first place, we provide a black color cutting mat with an overhead camera for the designers. After cutting, each piece is given a fiducial marker. The camera acquires an orthogonal, or "true-view" of the piece and links it to the marker ID and location. After combining the individual cardboard pieces, the composite digital model can be computed using the positions of the markers relative to a marker set on the foundation board for the model and the individual piece geometry. With such, a virtual model can be constructed from the physical model. If the designer wants to resize a piece, they only need to remove it from the model and adjust the size on the cutting mat before re-inserting it in the composition.

During model building, the projected simulation images from the host computer can help architects visualize analyses, such as shading, sun penetration, thermal diagrams, and visibility data. These images could be projected on 3-dimensional objects to illustrate the real-time situation in the current model. For example, shadows can appear on the ground as well as on the walls, windows and roofs. Projecting information onto the three-dimensional objects may benefit designers more than just presenting simulation results on the X-Y plane because these environment factors can affect the comfort of the residents in the building (not just on the ground). We also implement several fiducial markers as controllers for architects to adjust parameters for the simulation tool such as modify the time, change the modes, and editing the basic materials. Overall, our goal is to build a prototype that can be integrated into the existing design process with minimum disruption and maximum benefits.

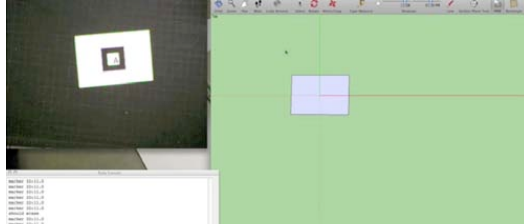

figure 2. Camera view in step 1 and scanned shape in the program

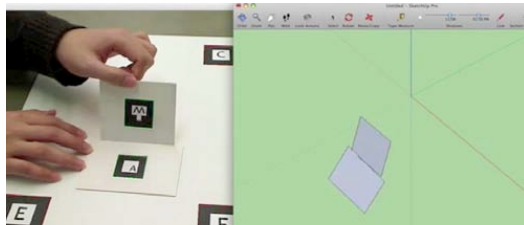

figure 3. Camera view in step 2 and the assembled two pieces of cardboard

System Overview

In this prototype, we modified ARToolKit 2.7 (ARTK) to address both vision tasks, and used an API for the widely available commercial modeling program, SketchUp to build the host-modeling environment. ARTK is designed for use in Augmented Reality applications. The TUI-AMA system utilizes the ARTK edge-detection code and the ability to register the location and orientation of fiducial markers. Three applications based on ARTK were created to complete the scenarios identified above. Step 1 is carried out by the "Shape Scanning Application" (SSA). Step 2 is completed by the "Location Detector Application" (LDA). "Image Projecting Application" (IPA) accomplishes the tasks in step 3. After these applications analyze frames from their respective

camera inputs, they transfer data to a custom script running in SketchUp. Our SketchUp add-on, "SketchUp Ruby Helper" (SRH), receives the data provided from the two ARTK applications and uses it to control the shape, location, and orientation of the geometry in SketchUp.

Figure 2 shows that a piece of cardboard against the black color cutting mat is scanned and appears in SketchUp. After cutting a piece of cardboard, the user is asked to attach a marker on it to let the program register the marker and recognize the shape. In this process, the application detects the bright edges for shapes and black edges for markers. After SSA finishes the scanning job, it transfers the data to SRH through Unix pipeline. If the marker is linked to a specific type of building element, the system then translates the building information data to the SketchUp program to calculate the simulation.

As shown in Figure 3, two pieces of building elements constructed on the "white foundation base" are updated in the SketchUp environment. The LDA calculates the related location and orientation data of the cardboard pieces in relations to the four base markers. These data drive the movement and rotation for the associated digital pieces in SketchUp. LDA also transfers the location data of the four base markers. These base markers can help IPA to analyze the accurate locations where the simulation images would project as shown in figures 4 and 5. The projector has to be pre-calibrated with the camera in step 2. To enable users to completely immerse in the physical environment without having to interact with a desktop machine for simulation, we implement several markers that can change the simulation mode, control specific time of sunlight, and switch materials.

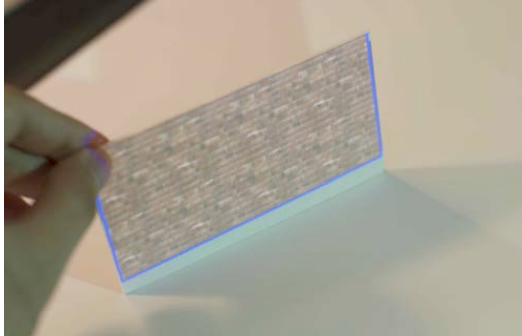

figure 4. Tracking a piece of cardboard and projecting (brick) textures on it

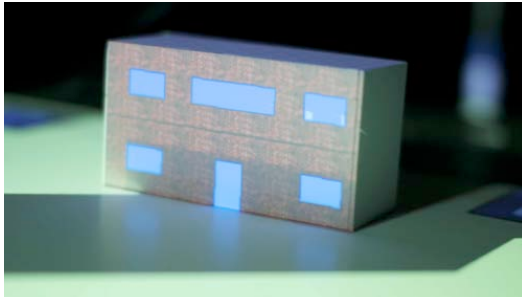

figure 5. Projecting a simulated shadow on a building

Discussion

By combining the three applications, the TUI-AMA system can produce and update a digital model from a physical model made by the user. The digital shapes can reflect the movement, shape, and position of a piece of cardboard in the physical world and provide simulation feedback. This prototype system also

enhances the information visualization and reduces the time requirement needed to build a digital model. The system brings computational power to the early stage of design when they engage in physical cardboard model making. As they explore different design alternatives the projecting images are overlaid on their physical models to provide feedback. Instead of using mouse and keyboard to run the simulation for the digital model, architects can modify the physical model immediately and intuitively with their hands. Architects can modify a piece of cardboard by physically cutting it, they can iterate through several design alternatives and test them with shadow simulations and texture mapping results. In this process, architects don't need to configure the physical and digital model in order to acquire the correct simulation information on specific location of their physical model. Therefore, the main contribution of the system is to bridge the digital and physical design platforms.

Currently, the weakest part of our prototype system is the processing speed while generating a new form from a piece of cardboard. User would need to wait for several seconds for the update and cannot test the piece of cardboard immediately. Requiring users to glue cardboard pieces in front of the view field of the camera may be a slight annoyance for some users. Currently we require the user to tag each marker attached to a cardboard piece in front of the camera as well. The pre-configuration of the projected images to the physical model is also very tedious and painful at this point.

Future Work

We are investigating what computer vision techniques to use to register each piece of cardboard without having to tag it with a unique marker. Employing 3-D

depth camera could provide us a tracking system by matching the shape in its scene and the geometry in the software system. The invisible infrared light markers such as what digital pen uses could also give us more reliable images for tracking since the visible images can be filtered out. We are also including more texture maps for different types of materials for the system.

We will conduct a formal user study to see how architects will respond to such seamless environment between digital and physical. We are investigating which types of information the users might need in this early stage of design. Finally, further research could extend the system for multiple designers to collaborate and communicate with each other.

Conclusions

We presented our TUI-AMA prototype system that assists architects by projecting simulation images on architectural models in real time. This system eliminates the labor for architects to build digital models after their physical models. We also discussed the limitations of the current prototype system and proposed future directions.

With the use of TUIs and overlaid information visualization, the boundary begins to blur between the digital and the physical worlds. When any physical object can be instantly given a digital representation and any digital data may be made evident in the physical world, the two begin to merge. Using computer vision, all objects in the physical world, not just the ones with sensors, can become part of our digital environment. The designer, able to work in either or both, may experience seamless flow of creativity and produces better design.

Acknowledgement

We thank Daniel Belcher, Randolph Fritz, members of DMG Lab at University of Washington and the Teatime group at Georgia Tech for giving us insightful feedback and suggestions.

References

- [1] Bandyopadhyay, D., Raskar, R. and Fuchs, H. Dynamic Shader Lamps: Painting on Movable Objects. In *Proceedings of the Proceedings of the IEEE and ACM International Symposium on Augmented Reality (ISAR'01)* (2001). IEEE Computer Society, 1-10.
- [2] Belcher, D. and Johnson, B. R. MxR A Physical Model-Based Mixed Reality Interface for Design Collaboration, Simulation. In *Proceedings of the ACADIA* (Minneapolis, 2008). CUMINCAD, 464-471.
- [3] Binder, T., Michelis, G. D., Gervautz, M., Jacucci, G., Matkovic, K., Psik, T. and Wagner, I. Supporting configurability in a mixed-media environment for design students. *Personal Ubiquitous Comput.*, 8, 5 (2004), 310-325.
- [4] Piper, B., Ratti, C. and Ishii, H. Illuminating clay: a 3-D tangible interface for landscape analysis. In *Proceedings of the Proceedings of the SIGCHI conference on Human factors in computing systems: Changing our world, changing ourselves* (Minneapolis, Minnesota, USA, 2002). ACM, 355-362.
- [5] Song, H., Guimbretièrè, F., Hu, C. and Lipson, H. ModelCraft: capturing freehand annotations and edits on physical 3D models. In *Proceedings of the 19th annual ACM symposium on User interface software and technology* (Montreux, Switzerland, 2006). ACM, 13-22.
- [6] Underkoffler, J. and Ishii, H. Urp: a luminous-tangible workbench for urban planning and design. In *Proceedings of the Proceedings of the SIGCHI conference on Human factors in computing systems: the CHI is the limit* (Pittsburgh, Pennsylvania, United States, 1999). ACM, 386-393.

Laser Cooking: an Automated Cooking Technique using Laser Cutter

Kentaro Fukuchi

Meiji University
1-1-1 Higashimita, Tama-ku
Kawasaki-shi, Kanagawa 2148571
JAPAN
Kentaro@fukuchi.org

Kazuhiro Jo

Art Media Center, Tokyo University
of the Arts
12-8 Ueno Park, Taito-ku, Tokyo
1108714 JAPAN
jo@jp.org

Copyright is held by the author/owner(s).

TEI'11, Work-in-Progress Workshop
Jan 23, 2011, Madeira, Portugal.

Abstract

We propose a novel cooking technology that using laser cutter as a dry-heating device. Generally a dry-heat cooking heats the whole surface of an ingredient, but laser-cutter enables to heat a sport of the surface in a very short time. Our approach employs an automated laser-cutter and video image processing technique to cook ingredients according to the shape and composition that enables to add new taste and texture, decoration and unique identifier to the ingredients. We introduce some examples of laser cooking of novel chocolate texture, healthy bacon precooking and 2D fiducial marker printing.

Keywords

Cooking, personal fabrication, laser cutter, gastronomy

ACM Classification Keywords

J.7 Computers in other systems.

Introduction

Personal fabrication is emerging: recently various automated machine tools can be purchased at a low price and individuals now can easily use these automated tools for personal manufacturing [1]. Automated tools help individuals by decreasing the painful process (e.g. cutting, curving, sculpting), and

improves the quality of their products that is comparable to commercial mass products. In this paper we proposed the idea of “personal cooking-fab” inspired by this movement that helps users to make novel, high-quality and a number of food products, and introduced “**laser-cooking**” using laser cutter for dry-heat cooking.

The history of the gastronomy is an effort of the improvement and invention of the cooking technology. For example, the discovery of fire opened the way of grill, baking, boiling, frying, etc. Drying, fermentation, chilling and freezing enabled long-term storing of ingredients and now we can purchase various foods through a year. The development of dishes and cutleries enabled to eat hot foods. Automated tools such as juicer or microwave decreased the burden of cooking and evolved the quality and speed of home cooking.

The “personal cooking-fab” introduces advanced automated machine tools to cook ingredients in order to help individuals to cook many ingredients and improve the quality, and find a new taste and texture in D.I.Y. style.

At first we focused on dry-heating technique and developed a novel cooking technique called “laser cooking”, that uses a laser cutter. In general, dry-heating only allows heating the whole of ingredients evenly, while our “**laser cooker**” enables to heat a spot of the ingredient locally in a very short time. By a combination laser heating and video image processing technique, the user can cook the ingredient according to its shape and composition, and introduce a local-heating method to achieve new taste. In this paper, we

introduce our current prototype of laser cooker and some examples of “nouvelle cuisine”.

Science, Engineering and Gastronomy

The development of science and engineering technologies increased evolved gastronomy, for example freezer, refrigerator, microwave, IH cooker, etc, etc. Nowadays more advanced cooking technology emerges. Kurti and This advocated “Molecular Gastronomy” that researches the scientific side of cooking and targeted to introduce new gastronomy. Sous-vide, or vacuum packed pouch cooking is known as a modern cooking technique using vacuum machine in order to make ingredients tasty without over-cooking it [2]. Adria et al use clothes iron, liquid nitrogen and various tools to create new taste and texture [3].

Dry-heating (grilling)

Using fire to heat ingredients introduced a number of new cooking methods. It makes ingredients safe, edible, crispy, savory and tasty. Heating tools are also evolved from direct flame to oven, gas cooker, microwave and IH cooker. The development of tools also introduced various cooking techniques such as boiling, frying, grill with a pot, pan, etc, etc.

However, usual heating tool heats the whole of ingredients evenly and it is difficult to heat it partially. In such cases, a dressing process is needed to protect a part of the ingredients. For example, “salt masking (*keshojio*)” is used to prevent fins fish charring by covering them with salt (figure 1). For microwave, aluminum foil can protect ingredients from microwave.



Figure 1. Salt masking (*keshojio*): covering the fish's fin with salt to prevent it charring (bottom).

Personal Fabrication and Laser Cutter

Automated machine tools become inexpensive and many "fab-labs" are established in worldwide that encourage D.I.Y. community. Those tools enabled individuals to make high-quality goods by themselves. In addition to the quality, they now can make their own things that implement exactly what they want to do with the help of computers and tools. The tools also enable mass production by individual and it opens up a new market, as seen in "Maker faire" [4].

Laser cutter is an automated cutting machine that uses a laser. It can cut materials rapidly and automatically, and it is becoming popular in personal fabrication scene with 3D printer. Not only cutting, but also it enables sculpting wider area by scanning the surface of the material. It operates the laser in two axes motion like X-Y plotter, so that it heats a very narrow spot on the surface to cut or sculpt. Usually laser cutter is used to cut or engrave material for modeling and decoration, but it can virtually be used to heat anything.

Laser Cooking

Laser cooking uses a laser cutter as a "laser-cooker" to heat ingredients in unusual way: it scans the surface of the ingredient with high-power laser to heat it according to a heat pattern. The system controls the power of the laser and the speed of the scanning, so that it enables various heating way such as low power-long term heating, or high power-instant heating. By using video image processing technique, the system creates a heat pattern according to the shape, position and composition of the ingredient.

Figure 2 shows the current implementation of the laser-cooker. An overhead camera captures images of ingredients on the stage of the cutter and the system recognizes their position, shapes, orientations and compositions.

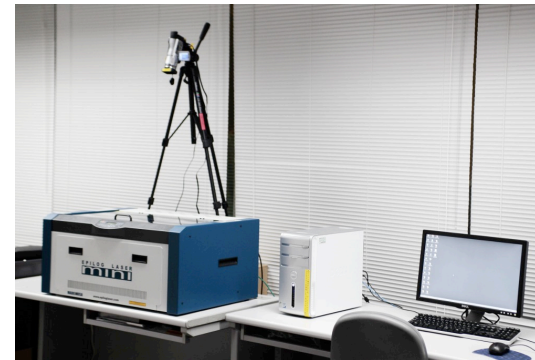

Figure 2. System overview: a laser cutter (Epilog Mini 24), an overhead camera and a PC. The camera captures images of ingredients on the stage of the cutter.

System Overview

Figure 2 shows the overview of the proposed system. The system consists of a laser cutter and a video camera. The video camera captures the still image of the stage of the laser cutter. A computer analyses the image from the camera and creates a heat pattern, then sends it to the laser cutter. When the laser cutter receives the pattern, it starts to operate the laser. In typical cases, the scanning takes 10-30 minutes.

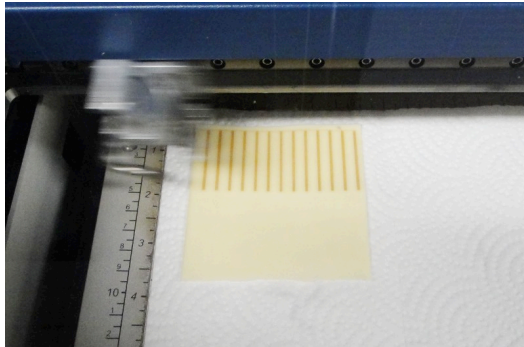

Figure 3. Laser cutter is running in engraving mode. In this picture it engraves a slice of cheese with a stripe pattern. Its surface is burned and the burnt pattern adds new taste, texture and smell.

Examples

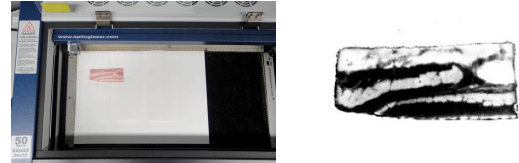

Figure 4. Raw image of the bacon (left) and a created heat pattern (right).

Here we introduce some example of laser cooking.

“Melt-fat raw bacon” is a combination of partial high-power heating and image processing. The taste of raw bacon is good but the raw and cold fat is sometimes unacceptable for its texture and taste. Laser cooking introduces a new method to precook raw bacon by heating only fat part of the bacon. The image analysis process creates a heat pattern from the camera image by detecting the fat part of the bacon (figure 4). At first the system detects the shape of the bacon, and then creates a gray-scaled image. The right of figure 4 shows the generated heat pattern: dark pixels represent high power, and light pixels represent low power area.

Then the heat pattern is sent to the laser cutter. Then the cutter cooks the bacon in raster engraving mode using the pattern. Figure 5 shows the result.

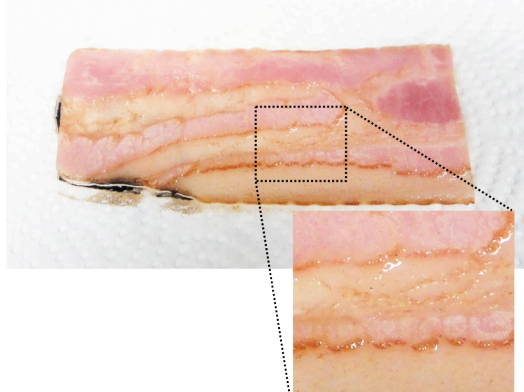

Figure 5. Laser-cooked bacon. Only fat part was roasted, while meat part is still raw.

The next example shows the way to integrate Virtual Reality / Augmented Reality technology to gastronomy. Figure 6 shows a cracker that a 2D fiducial marker is embedded in its surface. By using this marker, a VR/AR system can overlay computer graphics onto the cracker. Embedding fiducial marker by laser cutter extends Narumi et al.'s Meta-cookie system [5] by adding digital information to ingredients to show various visuals such as information of composition.

Conclusion

We proposed a novel cooking technology called "Laser Cooking" that using a laser cutter as a dry-heating device. The combination of the personal-fab style and image processing technique enabled advanced automated cooking and created new taste and texture. We introduced some experimental results of laser-

cooking, though the current implementation of the laser-cooker is work-in-progress and we are in the trial and error stage of laser cooking.



Figure 6. A 2D fiducial marker is embedded in a cracker.

References

- [1] N. Gershenfeld. Fab: The Coming Revolution on Your Desktop – from Personal Computers to Personal Fabrication, Basic Books (2005).
- [2] A. Hesser. Under Pressure. *The New York Times Magazine*, 2005-08-14 (2005)..
- [3] F. Adria. *Modern Gastronomy: A to Z*. CRC Press, 2009.
- [4] <http://makerfaire.com/>
- [5] T. Narumi et al. Meta Cookie. *SIGGRAPH '10 Poster No. 143*, ACM (2010).

Design factors which enhance user perception within simple Lego[®] - driven kinetic devices.

Emmanouil Vermisso

Assistant Professor
Florida Atlantic University
Fort Lauderdale, FL 33301 USA
archi_trek@hotmail.com

Copyright is held by the author/owner(s).

TEI'11, Work-in-Progress Workshop
Jan 23, 2011, Madeira, Portugal.

Abstract

Four 'primitive robot' prototypes (A,B,C, D) investigate the way an abstract idea becomes conceptualized through spatial diagrams which are then taken to CNC-fabrication: Projects A,B deal with natural locomotion, while projects C and D examine configurations of an unexpected and unusual purpose. The project operates within the boundaries traced by Heinz Von Foerster's metaphor of the 'Trivial machine'.

The projects raise questions of importance of the 'process' versus 'final output' and challenge the rules of the metaphor in which they operate: Can a system – through modification of inner relationships- cross the trivial/non-trivial condition repeatedly?

Keywords

Digital Fabrication; Non-trivial machines; Interactive patterning; user individuality

Introduction

1.1 Scope of project

It has often been debated whether architecture is defined by 'inhabitation', or by negation of the users (space alone) – occupation implies that one merely

experiences space through impression, a psychological occurrence which remains in one's memory. There is no haptic experience in the literal sense of a space reacting to the user. Perhaps, then, we should ask if architecture can be defined by 'interaction'. Through the investigation of 'prototypes' – small machines which produce a certain performance, this paper raises some potentially interesting questions for architectural design. Using a simple Lego motor, four primitive 'robot' prototypes (A, B, C, D) investigate the way an abstract idea becomes conceptualized through spatial diagrams which are then taken to CNC-fabrication. The evaluation of these systems is meant to provide conclusions about designed interaction. In this process, one should keep in mind the objective of these installations: how can they evolve, and what can they teach us (designer/user) about architecture? ie. How can we embed certain constructs within designed space to create reciprocity?

1.2 Description of the robots/prototypes

Using the metaphor of the 'trivial machine', the projects are classified into the categories of 'biological' and 'non-trivial' robots. Projects A and B deal with natural locomotion of Jellyfish (propulsion), and the snapping motion of the Venus fly-trap respectively. Project C uses a gear and belt system to create a breathing motion of a shape representing a mathematical geometry (epicycloid). Project D examines the interrelationship of moving assemblies of a familiar shape from which a chaotic pattern gradually emerges. The paper seeks to assess and compare the projects; nevertheless, more importance is placed on project D, because the nature of its function is more suitable for discussion.



figure 1. robot mechanism D: process involving both digital (laser-cutting) and analog making; final piece

Analysis

2.1 Discussion of the 'robot' qualities in relation to specified parameters

Naturally, the projects can be analyzed based on their conceptual references-craftsmanship-technical complexity but overall, their experiential value is what makes them socially significant, that is, how they are viewed beyond mere static artifacts or objects of designed beauty/precision, and become appreciated within the sphere of interaction.

a. Conceptual basis & Purpose : The clear definition –or not- of the artefact's purpose is what preconditions the nature of its interaction with the observer/operator.

b. Aesthetics, Craftsmanship & Technical complexity: it is necessary to identify aesthetics where it supports concept and where it stands on its own. Craftsmanship on the other hand is essential; in a conceptual stage, a system always operates, but in physical terms craftsmanship becomes important.

c. Experience (Process) & Evolution of the system: The performance of the robots reflects directly their concept and technical complexity, thereby making the experience the primary consideration in the design.

2.2 Issues raised

2.2.1 TO WHAT EXTENT CAN THE METAPHOR OF THE TRIVIAL MACHINE BE USEFUL?

How can the physical implementation of the concept benefit, rather than handicap the system?

The non-trivial machine distinction increases the possibilities for the physical manifestation of a system; the concepts need to be described as three-dimensional constructs; their aesthetics become more, or less important depending on how integrated these are with

their function. Every additional physical piece added to the system reconfigures the way this interacts with the user.

In architecture, it's typically the other way around: ideas become crude when expressed physically, but in this case, the interaction becomes more informative when manifested physically because, for example joints, consist of several parts.

2.2.2 WHAT ARE THE CONSTRAINTS, DURING THE ABOVE TRANSITION (CONCEPTUAL TO PHYSICAL)?

Prototype D lowers a group of interconnected pieces into a tank of engine oil, subsequently removes it, and maps the movement of certain pieces onto a medium acting as a 'canvas' (paper, etc.). During testing the first prototype there was a clear need to contain the movement of the pieces sideways. This could be achieved by introducing 'guides' to orient the movement within a path. As a result, the prototype with guides may be classified as trivial or '1st degree non-trivial', whereas the one without guides as '2nd degree non-trivial' machine. Does such an addition, then, limit the infinite range of movement, making the non-trivial machine into trivial? Furthermore, is it correct to describe a system as 'trivial' machine up to a certain point and as non-trivial beyond this? Perhaps the actual presence of the guides is not what dictates this but rather their visual manifestation on the system, which affects the user's perception of the machine's future operation (one sees a number of guides and becomes unclear about the process).

2.2.3 IS PROCESS MORE IMPORTANT THAN RESULT?

In all cases, consideration of the emotional value by reference to satisfaction of the Vitruvian qualities of Delight and Utility, poses the dilemma of 'Process' over

'Final Output'? (process maintains interest in users, modifying expectation over time, but output creates delight through fulfillment (or not) of expectation). Prototypes A and B indicate a more legible performance where result is anticipated and reached in a relatively simple fashion, therefore becoming the primary factor; in prototypes C and D, the ambiguity of the final output presupposes a rewarding performance to compensate for an absence of simplicity.

2.2.4 IN WHAT WAY CAN SYSTEMS EVOLVE? DOES NATURE?

According to Glanville, a system may be a trivial machine to the designer and a black box to the user – Can such a machine (through autonomous change of its inner function) over time, become a black box to the designer due to increased unpredictability? It may be important at this point to state the primary traits which set apart trivial from non-trivial machines:

Trivial: Synthetically determined; History independent; Analytically determined; Predictable.

Non-trivial: Synthetically determined; History dependent; Analytically indeterminable; Unpredictable.

a. In the case of biological machines, as in projects A and B, the function is clear, the goal is survival; however, the design of the machine which is partly affected by physical factors may -by choice- blur the clarity of the function and collapse the typically linear nature of the system's goal, side-tracking the observer's focus elsewhere: The design of prototype B for example, includes a series of different size components (gears etc.) to enhance the process but also for technical reasons like reducing the machine's speed.

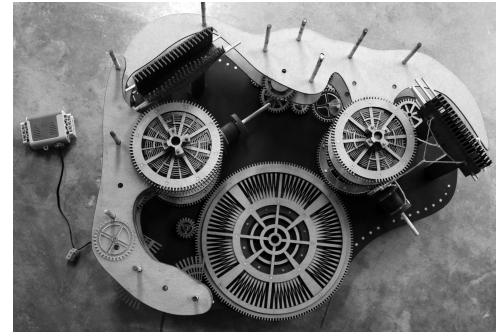

figure 2. 'Biological' machine (Venus fly-trap)

It may be useful to consider describing the machines' behavior with symbols; does their interaction with the user operate on one or more levels of complexity?
 one level: input [1]→output [1], in [2]→out [1]... in [n]→out [1]
 many levels: in[1]→out [1], in [2]→out [2]... in [n]→out [n]

Vis-à-vis projects A and B, it is worth considering which model is true for natural systems. Nature is typically seen as a 'trivial' machine: complexity is used towards a specific end. If this is viewed as optimization, it becomes 'deterministic', and inflexible. In nature, however, input keeps changing due to unstable factors so natural strategies follow a stochastic (adaptive) approach: optimization is relative to time and space. Can the above notations still describe this model? It may be necessary to specify the 'type' of input in the above described models: a different input can merely indicate another user who, nevertheless, pushes the same button without affecting the internal function of a

system: input [1user]. Also, a different input may indicate an external parameter changing (ie. solar activity) which affects the same internal function once a user has pushed this button: input [1user +1ext.]. Nature displays this second category of constantly changing inputs, so it belongs to a modified version of the first model: input [1user +1ext.]→output 1, in [2user +2ext.]→out 1...in [nuser +next.]→out [1]. It may therefore be possible to subvert the notion of nature as 'trivial' machine (evolution takes place, system adapts).

b. In the case of project D, can we change the complexity over time, to change not only the system-user relationship but also the system-designer relationship?

As mentioned earlier, this prototype creates a 'painting' by visually mapping point movement on a replaceable medium. The individuality of its output and its ambiguity classifies this as non-trivial, according to the characteristics stated above (2.2.4). The machine's experiential value is perhaps analogous to the clarity (or absence of) its function: from a teleological point of view, blurring the user's perception, or changing this perception during the interaction is of interest here: project D machine has an infinite range of possible outcomes, but what happens if this is limited to once per user? Assuming the current world population there are approx. 6.8 billion outcomes. Can we, therefore, make a machine from non-trivial to trivial by allocating a certain convention to it?

When the system becomes a black box to the designer is this non-trivial machine, or is it merely too complex to assess quantitatively? If the possible outcomes were

computable, it would remain trivial to the designer (?) Maybe this depends on the factor which removes the authorship from the designer – a series of internal loops really need to occur in order to convert a system

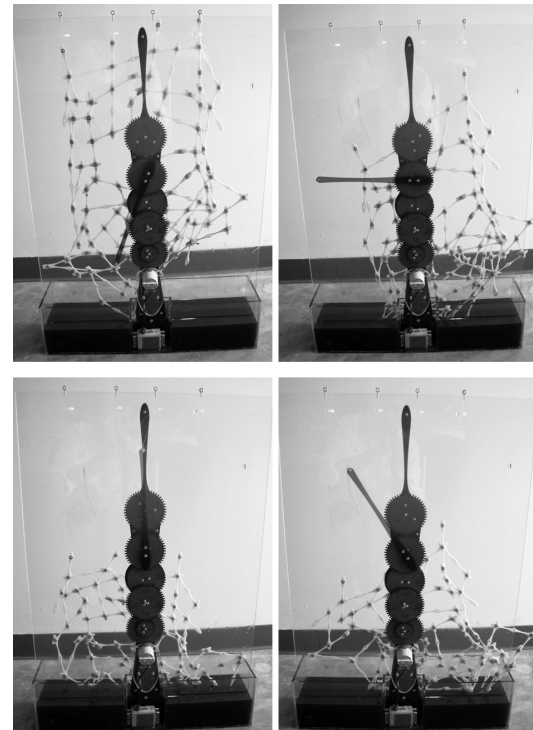

figure 3. Diagram of transformation of inter-related parts over time (stages 1-4 seen clockwise)

to non-trivial towards the designer. In robot D, these 'loops' may be designed based on the pattern formed by the pieces. The overall system in its original, static condition contains certain familiar shapes, like a square, which gets progressively deconstructed until it is no longer legible. The extent of this distortion depends on the joints of the pieces which form the square, and the inner pieces which allow distortion.

To ensure a finite number of outputs, additional inputs may be introduced to check user identity (ie. Biometrics); this creates another 'subjective' layer of input. It is interesting to consider the gap between conceptualizing this subjectivity and actually mapping this on the machine (the design aesthetic of the object is inevitably affected to a point where the perception of the user also changes).

If project D is mounted on wheels, or placed on a track, the user may be allowed to relocate this within a given space, thus creating an unpredictable combination of results (mixed order of painted surfaces – If the machine draws on a wall, then the order of the patterns will become more confused with every additional user). In this way, architectural ornament can be created not

Acknowledgements

I would like to thank all my digital fabrication students at the Florida Atlantic University School of Architecture for their hard work and enthusiasm in seeing these ideas through to a physical product, in particular Beiqi In, Shannon Brown, Ross Downing, Liza Turek and Ashley Wright.

by the designer of the space but from the user of the designer's constructs within that space. The output of the project extends beyond individual pieces to become an evolving performance, something analogous to the surrealist 'exquisite corpse'.

Conclusion & further development: Evolution of system over time in reverse

Regarding the evolution of a system (see point 2.2.4), it is interesting to consider the difference between Newtonian (symmetrical) and Bergsonian (irreversible) time, as explained by Norbert Wiener in 'Cybernetics': 'The relation of these mechanisms to time demands careful study. It is clear, of course, that the relation input-output is a consecutive one in time and involves a definitive past-future order...' (Wiener 1965). One may claim, that natural models -in so far as they are viewed as trivial machines- display a certain symmetry (fixed goal) and thus can be reversed. Non-trivial machines, however, evolve asymmetrically (unpredictably) and cannot be analyzed by the Newtonian model. Can we design our system (project D) so the pattern of its operation displays certain asymmetry, which is controlled by the designer once the process is reversed?

References

- [1] Gage, S. The Wonder of Trivial Machines, *Protoarchitecture: Analogue and Digital Hybrids*, Architectural Design (2008), 14-21.
- [2] Von Foerster, H. Anthology Of Principles Propositions Theorems Roadsigns Definitions Postulates Aphorisms Etc. (<http://www.cybsoc.org/heinz.htm>)
- [3] Wiener, N. Cybernetics, Second Edition: or the Control and Communication in the Animal and the Machine, MIT Press (1965)

Augmented Mobile Technology to Enhance Employee's Health and Improve Social Welfare through Win-Win Strategy

Hyungsin Kim

GVU & College of Computing
Georgia Institute of Technology
Atlanta, GA USA
hyungsin@gatech.edu

Hakkyun Kim

John Molson School of Business
Concordia University
Montreal, QC Canada
hkim@jmsb.concordia.ca

Ellen Yi-Luen Do

GVU, College of Computing &
College of Architecture
Georgia Institute of Technology
Atlanta, GA USA
ellendo@gatech.edu

Copyright is held by the author/owner(s).
TEI'11, Work-in-Progress Workshop
Jan 23, 2011, Madeira, Portugal.

Abstract

In this paper, we present an augmented mobile technology that plays a critical role to enhance the positive health behavior of employees as well as companies' social welfare. Simply by using mobile phones, employees are able to be encouraged to walk more and to transform their walking behaviors into a tangible donation. We have applied two social behavior theories to our technology design and also propose two conceptual models that provide a step-by-step approach to enhance employees' health and improve social welfare.

Keywords

Health management system, corporate social responsibility, consumer-driven health care, health promotion and wellness

ACM Classification Keywords

H5.m. Information interfaces and presentation (e.g., HCI): Miscellaneous.

General Terms

Human Factors, Design.

Introduction

Our lifestyles in the 21st century on average lack the basic recommended daily physical activity. This sedentary way of living causes several major public health problems [3]. Research shows that people who are physically active can reduce their risk of developing major chronic diseases such as coronary heart disease, stroke, and type 2 diabetes by up to 50% as well as reduce the risk of premature death by about 20~30% [8]. Also, as shown in Figure 1 prepared by the British Department of Health, physical inactivity at all stages of life contributes to negative effects (e.g. diseases, disorders, and premature mortality), and the risks tend to become greater as people age.

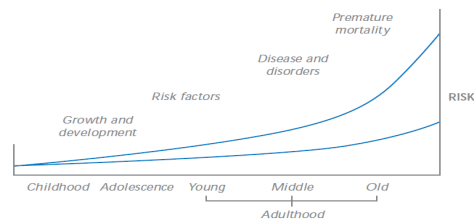

The upper line represents risk for individuals with an inactive lifestyle.
The lower line represents risk for those with an active lifestyle.

Figure 1. A lifecourse perspective on the effect of activity on disease risk

The World Health Organization (WHO) emphasizes that the workplace is a priority setting for health promotion [10]. The most popular wellness and health promotion programs cover increasing physical activity as well as healthy nutrition knowledge. [9]. While the workplace

directly influences the physical, mental, economic, and social wellbeing of workers, the sedentary nature of most workplaces may also contribute to employees' unhealthy habits [2].

Given that employees still spend a significant portion of their time at their office working, which may be negatively linked with a reduction in physical activity, there is now a need for new mechanisms that can align the health benefits for the employees and benefits for the firms so that each party views health promotion as a solution for a win-win outcome, not as a trade-off relationship in which one wins but the other loses. Furthermore, given the increasing demands for sustainability and corporate social responsibility (CSR), firms are being asked to perform more socially desirable functions and become an active part of the community. Unfortunately, all the separate pieces mentioned above have not yet been treated from an integrative perspective that considers the organic relations among them (employees, firms, the communities).

We propose an augmented mobile technology that can facilitate the promotion of good health at the workplace as a solution to benefit all the related stakeholders.

In this paper, by choosing everyday walking as a focal type of physical activity, we propose two conceptual models which are based on the concepts of corporate social responsibility and behavioral economics. We also discuss how technology can be implemented. Ultimately, we intend to show how everyday walking can be assigned additional meanings, both economic and social in our proposed models, and how employees, firms, and communities can all win by adopting these models.

Incentive based Human Behaviors

According to incentive theory in psychology, an individual's motivation and behaviors are influenced by beliefs that their activities can bring profitable benefits

[7]. Incentive theory involves positive reinforcement and has been used in designing and developing human behavior changes or new habits. Also, on the corporate side, firms use this theory to structure employees' compensation in a way that the employees' goals are aligned with the owners' goals. Financial incentives are tools to encourage behaviors or outcomes based on this theory. Companies adopt incentive theory in a variety of forms such as yearly bonuses, penalties, stock options, and pay for performance. In his article, "Rethinking rewards", Guzzo (1994) argues that incentives are very powerful for motivating the behavior they reward [5]. In order to encourage employees to develop healthy habits such as regular everyday walking, our two proposed models use the notion of incentive-based human behaviors.

Corporate Social Responsibility

Over the last two decades, Corporate Social Responsibility (CSR) has become a significant issue for large multinational companies. Simply speaking, CSR has become an important business strategy. For example, "consumers want to buy product from companies they trust; suppliers want to form business partnerships with companies they can rely on; employees want to work for companies they respect; and NGOs, increasingly, want to work together with companies seeking feasible solutions and innovations in areas of common concern [4]."

CSR emphasizes businesses should cooperate within society [6]. CSR means more than just making financial contributions. People expect corporations to be engaged in their communities in a variety of ways. It also involves multiple stakeholders, including the government, shareholders, employees, consumers, the media, suppliers, NGOs, and the general public.

Satisfying each group while minimizing conflicts will allow companies to develop a new win-win situation.

Recently, Corporate Social Responsibility has invested in employees' health and well being. Designing successful interventions in health would provide significant returns such as increasing productivity, profitability, and savings in healthcare costs. CSR can also be used as a way to connect companies to non-profit organizations. In our proposed model, we describe how an individual employee's physical activity for good health can contribute not only to an increase in a company's CSR but also to donations for nonprofit organizations. Corporate Social Responsibility is also interchangeably used to indicate corporate responsibility, corporate citizenship, responsible business, sustainable responsible business (SRB) or corporate social performance.

Two conceptual models to improve employees' everyday walking

We propose two conceptual models to improve employees' everyday walking. Employees can use their coffee break time for 10 minutes of walking, or they can use stairs instead of elevators. They can even use lunchtime for 30- minute group walks outside the building. Both models take into consideration the relationship between a company and its health cost (for example, paying fees to an insurance company for their employees).

The Simple profit-based model

The simple profit-based model focuses on the individual employee's role and its relationship with respect to an insurance company. Figure 2 shows the inter-relationship among companies. Company X provides

collective data of employees' everyday walking or steps and then Insurance Company Y will reduce insurance costs based on the collective data.

In this model, a company's main roles are (1) to promote employees' walking by providing sufficient incentives, monetary or non-monetary (for example, promotion, benefit) and (2) to enlighten/educate employees regarding the importance of personal health management and provide easy steps for achieving good health conditions (e.g., walking). The three benefits the company would have are (1) to improve employees' well-being by enhancing their health, (2) to create an active work environment which may induce efficiency/efficacy of jobs, and ultimately (3) to reduce insurance costs.

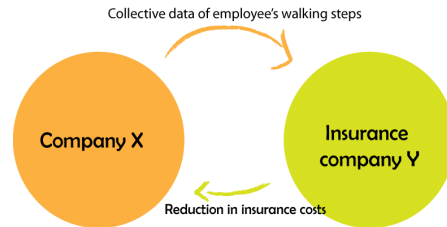

Figure 2. Simple Profit-Based Model

The main roles for an insurance company would be (1) to increase the number of participating companies and (2) to monitor the relationship between walking behaviors and health conditions/health-related costs. The insurance company will have three benefits by (1) improving their client company's health, (2) reducing their outgoing expenditures in medical expense coverage, and (3) reducing transaction costs via reduced numbers of claims and inquiries.

Extended non-profit based model

Our second model is extended to include non-profit organizations in their relations. In figure 3, we describe each model and how it works. In addition to the company's role in the Simple Profit-Based Model, the major roles of the extended non-profit based model are (1) to envision a societal role for firms among employees, (2) to add meanings to the employees' participation in the walking program, and (3) to select causes or charity organizations as the beneficiaries. A company's benefits are also extended (1) to gain positive brand image/social legitimacy from the public, (2) to increase awareness of the brand among prospective consumers, and (3) to gain tax benefits.

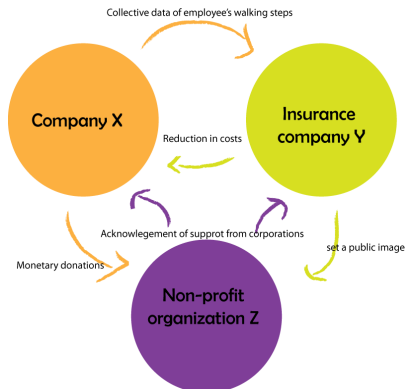

Figure 3. Extended Non Profit-based Model

An insurance company also plays another role by relaying participating clients' contributions to charity organizations, either in monetary contributions or assistance in insurance programs. Two more benefits would be added: (1) to create a public image and (2) to



Figure 5. Screen shot showing User Interface

increase the potential for broadening the customer base. Nonprofit organizations play an important role in our extended non-profit based model. Their roles are (1) to sustain and expand their intended programs/causes and (2) to publicly acknowledge support from corporations. Their main benefits would be (1) to achieve their fund-raising goals, and (2) to further garner individual donations by becoming a trusted cause with corporate sponsors.

Technological Implementation

This section provides an overall structure of data transfer from individual employees to company, to insurance company and to non-profit organization, as shown in Figure 4. Currently pedometers or step counters are popularly used as everyday exercise measurers or motivators. Pedometers are portable and can also be integrated into personal electronic devices such as mobile phones. There are five main features implemented in the mobile phone application: Steps, Distance, Calories, Insurance, and Donation.

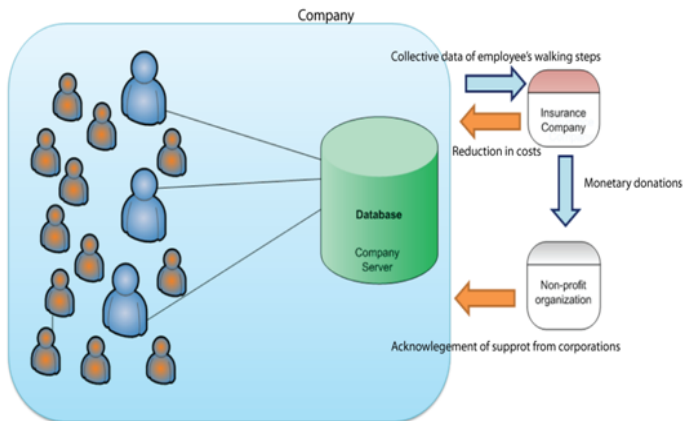

Figure 4. Data transfer among company, insurance company, and non-profit organization

As shown in Figure 5, the Steps icon shows the number of steps a walker takes. The Distance icon displays a user's walking distance in miles or kilometers. The Calorie icon shows a user's calculated calories burned based on the user's exercise considering the individual's weight, height, walking distance and the level of the ground. For example, walking uphill will be differently calculated from walking on level ground. The last two icons show how walking can impact the insurance cost as well as the donation. As for the donation, an individual user can set his or her own goals, such as donating money to save a child in Africa, buying everyday essential products for refugees, or rescuing homeless animals.

The individual employee's steps will be calculated and tallied every month. The data will then be sent to the insurance company. Based on the steps the employees contribute, an insurance company will decide how much reduction in insurance costs to award. Furthermore, if the company wants to donate their cost reduction fees to a non-profit organization, the insurance company would directly send money to the non-profit organization.

Future direction

After completing our prototyping development, we will plan to conduct a user study using a field experiment. This experiment (N = 80) is designed to test whether endowing individuals with incentives (monetary or social) influences participation in a physically active life (i.e., walking). Specifically, this experiment is intended to examine whether people whose walking is compensated by donations to a social cause of their choice (social incentive condition) will walk more compared to those whose walking is compensated with reductions in their own insurance costs (individualistic incentive condition).

The experiment further seeks to find whether people in incentive conditions will walk more relative to those who are not given any incentive (control condition). Participants (who will be randomly assigned to one of the three conditions) will be asked to install the application we develop in their phone. Their walking record over the next few months will be the key dependent variable.

Conclusion

In this paper, first, we proposed two conceptual models that seek to increase everyday walking for employees, decrease health insurance costs for employers, and ultimately contribute to our society's well-being: a win-win situation. By using this overarching model, companies will simultaneously meet the two goals: promoting their employees' health as well as increasing corporate social responsibility. An augmented mobile technology can play a new role as a facilitator to help companies increase cooperative social responsibility through a change in employees' lifestyles. In this paper, we intend to show simple everyday walking as an example of physical activity. However, it can be extended and modified by applying this model to other forms of contribution from individual employees in addition to other methods of promoting companies' corporate social responsibility.

References

- [1] British Department of health. (2004). At least five a week: Evidence on the impact of physical activity and its relationship to health. Department of Health Physical Activity, Health Improvement and Prevention. April 29
- [2] Brunner, B. (2003). Worksite Health Promotion - Online Research. <http://www.esdproj.org/>

- [3] Caspersen CJ, Powell KE, Christensen G. (1985). Physical activity, exercise and physical fitness: definitions and distinctions of health-related research. *Public Health Reports*; 100:126-131.
- [4] Chandler, David & Rindova, Violina, 'Would You Like Fries With That? Producing and Consuming Social Measures of Firm Value, Academy of Management Annual Meeting, Anaheim CA, 2008
- [5] Guzzo, R. (1994, January). Rethinking Rewards. *Harvard Business Review*, 72(1), 158-159.
- [6] Hancock, John (2005) Investing in Corporate Social Responsibility: A Guide to Best Practice, Business Planning & the UK's Leading Companies. Kogan Page.
- [7] Mankiw, N. Gregory. (1998). Principles of Microeconomics. The Dryden Press. Orlando, FL
- [8] USA Department of Health and Human Services. (1996). Physical activity and health: a report of the Surgeon General. Pittsburgh, PA.
- [9] Watson Wyatt Worldwide. (2008). Realizing the Potential of Onsite Health Centers <http://officemdsf.com/>
- [10] World Health Organization. Workplace health promotion. http://www.who.int/occupational_health/topics/workplace

Rotoscopy-Handwriting Prototypes for Children with Dyspraxia

Muhammad Fakri Othman

Cardiff School of Art and Design
Univ. of Wales Institute, Cardiff
Cardiff CF5 2YB, United Kingdom
faothman@uwic.ac.uk

Wendy Keay-Bright

Cardiff School of Art and Design
Univ. of Wales Institute, Cardiff
Cardiff CF5 2YB, United Kingdom
wkbright@uwic.ac.uk

Stephen Thompson

Cardiff School of Art and Design
Univ. of Wales Institute, Cardiff
Cardiff CF5 2YB, United Kingdom
sthompson@uwic.ac.uk

Clive Cazeaux

Cardiff School of Art and Design
Univ. of Wales Institute, Cardiff
Cardiff CF5 2YB, United Kingdom
CCazeaux@uwic.ac.uk

Copyright is held by the author/owner(s).

TEI'11, Work-in-Progress Workshop
Jan 23, 2011, Madeira, Portugal.

Abstract

The paper discusses work-in-progress on the development of series of prototypes intended to support handwriting skills for children with dyspraxia, using a specialist animation technique known as rotoscopy. We explain how rotoscopy may provide a novel, engaging and motivating technology intervention for this group, enabling them to use naturalistic movement to practice handwriting skills.

Keywords

Computer animation, rotoscopy, handwriting, dyspraxia

ACM Classification Keywords

H.5.2. User Interfaces: Prototyping.

General Terms

Design

Introduction

Rotoscopy is a traditional animation technique that has been comprehensively adopted in computer animation. Rotoscopy is a technique in which animators trace over live-action film movement for use in animated films [2]. It captures human movement in such a way that it can be animated in a simplified form to convey naturalistic actions [1]. Figure 1 depicts examples of rotoscopy effects whereby a photo becomes a simple 2D graphic and video footage translates to a short 2D animation.

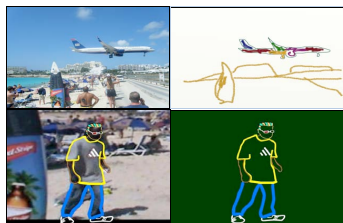

figure 1. Sample of rotoscopy results

Previous work

Previous research in Rotoscopy has focused on techniques for 2D graphics and animation, such as *Contour Tracking* [1] and *SnakeToonz* [3]. Rotoscopy typically produces non-photorealistic sequential images and demands human effort to trace object contours from captured video sequences. In addition to this, tracking is a process in rotoscopy that captures video in order to transform to 2D or 3D graphics and animation. Though a few tracking algorithms have been introduced, such as *Keyframe-based Tracking* and *Bi-directional Tracking*, previous research in rotoscopy and animation focuses more on video and 2D image rather than producing 3D output.

Dyspraxia is a motor learning disability where people have difficulty planning and organising smooth coordinated movements [4]. Other terms, such as developmental co-ordination disorder (DCD), Clumsy Child Syndrome, minimal brain dysfunction, and perceptuo-motor dysfunction are also used to describe dyspraxia [5]. Research on the efficiency of e-learning and multimedia computer technology for children with learning difficulties strongly supports our approach as it has demonstrated positive results [6].

Rotoscopy may have a particular application for this target group due to the highly visible nature of the graphical output. This is critical for dyspraxic children who have difficulties in hand movement as well as handwriting since rotoscopy provides activity to sketch over the top of border of images as an exercise to improve their fine-motor skills. A study of sign language co-articulation has been undertaken using the rotoscopy technique [7] as it promotes movement to perform signs using hands. Walden's research [8] found that technical advances of rotoscopy have had aesthetic consequences not just for the quality of image but also to the nature of the actor's performance within animation.

In terms of handwriting, Boyle [9] has revealed children with Moderate Learning Difficulties (MLD) like dyspraxia can be helped to improve their handwriting using simple a intervention programme such as a speed of handwriting exercise, with support of other general gross motor coordination test. Meanwhile an investigation by Snape and Nicol [10] using a pen-based computer writing interface, has demonstrated a positive improvement for children, although it hasn't employed rotoscopy for their system.

Why Rotoscopy?

Rotoscopy may provide a suitable handwriting application as it allows the user to trace hand movement along specific guided lines. Furthermore, rotoscopy enables children to learn through play via tracing and drawing of still images and video footage. The flexibility of rotoscopy is another benefit for children with dyspraxia as it allows a for many novel and developmentally appropriate inputs.

For instance we can use a favourite character as a background image as a practice for hand movement, or a live video of children faces and tracing it using rotoscopy system.

Experience prototyping

In order to design, develop and implement a robust technology system we are currently developing series of iterative prototypes. Our design methods consist of three different phases of Experience Prototyping [11] known as 'looks like', 'feels like' and 'works like' prototypes. 'Looks like' is more on physical of the system, 'feels like' refers to how to use it and 'works like' is about how the user experienced the system. Target users will be involved in all stages of the design process from the storyboarding, interface design, programming and system testing.

Usability testing

We will conduct usability testing by working with experts and offering appropriate activities with prototypes to selected dyspraxic children (end-users). The process will be fully-guided by experienced and qualified professionals and captured on video for further analysis using standardized observation scales. The implementation of prototypes and testing process will be held at a dyspraxia research centre. We have established a connection with Dyscovery Centre, University of Wales, Newport, a specialist research centre for children with dyspraxia and other learning difficulties. The metrics of testing are video coding and observation, involving series of different version of prototype; since all these are techniques applied in user observation and informant design approach.

We use *Wechsler Intelligence Scales for Children®* (WISC) [12] as the evaluation standard. WISC is a special intelligence test designed for children age 6 to 16 to generate their IQ score as well as to diagnose children's learning disability. Results will be measured on children's performance, and how the application helps users to improve their fine-motor skills, as well as their interest and motivation towards learning.

Medium of interaction

The interactive whiteboard has been used in a classroom to test the prototypes as well pre-writing activities. It has been chosen as it has touch screen mode that allows children to make free hand movements on the screen [13]. The concept is quite similar to pen and graphics tablet it affords a more spacious movement area. Previous research using pen-based computer writing interface [14] has demonstrated its effectiveness in comparison to traditional pencil and paper. Figure 2 shows children using interactive whiteboard.



figure 2. Children using the interactive whiteboard

Prototype interface

The prototype system is designed to assist children with dyspraxia in practicing their handwriting skills through movement and performance, which is mirrored via the projection of actions onto a large surface.

Evaluation methods will measure the extent to which the animation of movement in a child-friendly graphic form can engage children's motivation and lead to improved handwriting skills [14]. The prototype that has been designed and developed is based-on Ripley's Methods for teaching of handwriting to children with dyspraxia [5]. Ripley's method consists of different stages of skills: Prototype 1: Group 1 to Group 4 Symbols, Prototype 2: Numbers, Prototype 3: Circle Letters, Prototype 4: Wiggly Letters and Prototype 5: Child's Name. Each stage has a different level of difficulty that needs to be completed before the student can move to a higher level. Figure 3 and Figure 4 are examples of early version of the first two groups of basic shapes. These shapes are a basic hand movement and gesture practice for children with dyspraxia before they move on to more complex letters. Children's interaction with the system occurs with the use of interactive whiteboard to test the prototype.

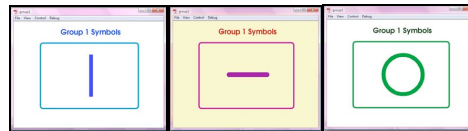

figure 3. Group 1 Symbols

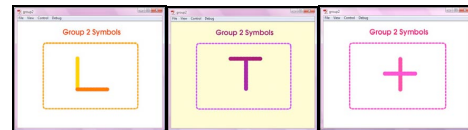

figure 4. Group 2 Symbols

For Prototype 1, Group 1 to Group 4 symbols, children or user need to master basic lines and shapes in order to train their hand movement. Group 1 consist of three most fundamental shapes, a horizontal line for hand movement from left to right (and vice versa), a vertical line for hand movement from top to bottom and a circle for round or curve hand movement. Figure 5 illustrates the first three interfaces that allow children to draw horizontal and vertical lines as well as circles on interactive whiteboard using the early version of rotoscopy-handwriting prototypes.

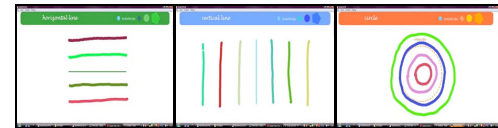

figure 5. Prototype 1: Group 1 symbols

Meanwhile examples of learning to write a single letter are shown in sequences from start to end (Figure 6 to 8). In Figure 6, the first interface is steps with arrows to show how to write the letter and the second is demo animation of the steps. Figure 7, the interface shows the rotoscopy process, where users are allowed to trace the letter, followed by two interfaces for exercise.

For exercise, the first interface allows user to train to write the letter with reference or guide (a watermarked image of the letter), but the second is an exercise without references, assuming the user already know how to write the letter. Figure 8 shows sample exercise of the last two interfaces.

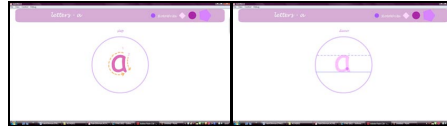

figure 6. Steps and demo animation

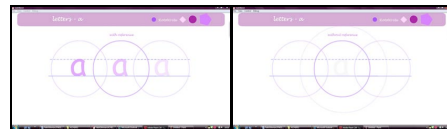

figure 7. Two exercise interface



figure 8. Samples of exercise

Pre-writing activity

We have also created a prototype pre-handwriting activity to see how children with dyspraxia and typically developing (TD) children respond to the system as well as its design and usability. Figure 9 shows free drawing results obtained from a group of TD children age 6 to 9 playing with rotoscopy function. From the study it emerged that such an activity was really fun and interesting for them. From this experiment we are adapting the system design for children with dyspraxia to ensure that it is easier to use. The next version of our prototype will use a pen tablet and a monitor. Children will be able to use their fingers as well as the pen to draw lines and shapes on the screen.

The size of the shape should be drawn according to the screen's medium of display; for example when using interactive whiteboard; a bigger shape size is required whilst for monitor-based display, smaller size is preferred.



figure 9. Samples of rotoscopy pre-writing activity

Conclusion and future work

The goal of this investigation is to discover the potential of rotoscopy to assist the teaching of handwriting skills for children with dyspraxia. With evidence gathered from our prototype systems, the proposed methods may place these developments in an original context. Rotoscopy may prove appropriate for children with dyspraxia as it enables them to practice their skills using naturalistic hand movement.

In this case, the input and output device play important role as a medium of communication between children and the methods; as this tangible technologies have a close correspondence in behavioural meaning between input and output. Our next milestones will be to undertake contextual analysis [15] of the prototype systems which will include end user feedback and practitioner reflection.

Acknowledgements

A special thanks to University of Wales Institute Cardiff (UWIC), The Dyscovery Centre, University of Wales Newport, Universiti Tun Hussein Onn Malaysia (UTHM), Ministry of Higher Education Malaysia, and our beloved family for their supports.

Citations

- [1] V. Garcia, E., Debreuve, and M. Barlaud, "Contour Tracking Algorithm For Rotoscopy," Proc. ICASSP 2006: IEEE International Conference On Acoustic Speech.
- [2] A. Agarwala, A. Hertzmann, D. Salesin, and S. Seitz, " Keyframe-Based Tracking for Rotoscoping and Animation," Proc. SIGGRAPH, Aug. 2004, pp. 584–591, doi: <http://doi.acm.org/10.1145/1186562.1015764>.
- [3] A. Agarwala, "SnakeToonz: a semi-automatic approach to creating cel animation from video," Proc. 2nd ACM International Symposium on Non-photorealistic Animation and Rendering 2001. pp 139-ff.
- [4] M. Boon, *Helping Children with Dyspraxia.*, Jessica Kingsley Publishers, 2001.
- [5] K. Ripley, B. Daines, and J. Barrett, *Dyspraxia: A Guide for Teachers and Parents.*, David Fulton Publishers, 1997.
- [6] A. Savidis, and C. Stephanidis, "Developing inclusive e-learning and e-entertainment to effectively accommodate learning difficulties," SIGACCESS Access. Comput. , 83, Sep. 2005, 42-54.
- [7] J. Segouat, "A study of sign language coarticulation," SIGACCESS Access. Comput. , 93, Jan. 2009, 31-38, doi:<http://doi.acm.org/10.1145/1531930.1531935>.
- [8] K. L. Walden, "Double Take: Rotoscoping and the processing of performance," *Refractory: a journal of entertainment media*, Dec. 2008.
- [9] C.M. Boyle, "An Analysis Of The Efficacy Of A Motor Skills Training Programme For Young People With Moderate Learning Difficulties," *International Journal Of Special Education* 2007, Vol 22, No. 1,pp 11-24.
- [10] L. Snape, and T. Nicol, "Evaluating the effectiveness of a computer based letter formation system for children," Proc. The 2003 Conference on Interaction Design and Children, 2003.
- [11] M. Buchenau, and J. F. Suri, "Experience prototyping," Proc. The 3rd Conference on Designing Interactive Systems: Processes, Practices, Methods, and Techniques; August 17 - 19, Aug. 2000, doi: <http://doi.acm.org/10.1145/347642.347802>.
- [12] E. Kaplan, D. Fein, and J. Kramer, "Wechsler Intelligence Scale for Children® - Fourth Edition Integrated," 2004, Available at: <http://www.pearsonassessments.com/HAIWEB/Culture/en-us/Productdetail.htm?Pid=015-8982-800>
- [13] W. Keay-Bright, "Designing Playful Sensory Experiences with Interactive Whiteboard Technology: The Implication for Children on the Autistic Spectrum," *EAD* 07, 2007.
- [14] J.C. Read, S. MacFarlane, and M. Horton, "The Usability of Handwriting Recognition for Writing in the Primary Classroom," *People and Computer XVIII - Design for Life*, Springer, London, 2004, doi:10.1007/b138141.
- [15] M. Stringer, E. Harris, and G. Fitzpatrick, "Exploring the space of near-future design with children," Proc. The 4th Nordic conference on Human-computer interaction: changing roles, doi:10.1145/1182475.1182512

A Savvy Robot Standup Comic: Online Learning through Audience Tracking

Heather Knight

Carnegie Mellon University
Robotics Institute
5000 Forbes Ave
Pittsburgh, PA 15213 USA
heatherbot@cmu.edu

Scott Satkin

Carnegie Mellon University
Robotics Institute
5000 Forbes Ave
Pittsburgh, PA 15213 USA
ssatkin@andrew.cmu.edu

Varun Ramakrishna

Carnegie Mellon University
Robotics Institute
5000 Forbes Ave
Pittsburgh, PA 15213 USA
varunr@cmu.edu

Santosh Divvala

Carnegie Mellon University
Robotics Institute
5000 Forbes Ave
Pittsburgh, PA 15213 USA
santosh@ri.cmu.edu

Abstract

In this paper, we propose Robot Theater as novel framework to develop and evaluate the interaction capabilities of embodied machines. By using online-learning algorithms to match the machine's actions to dynamic target environments, we hope to develop an extensible system of social intelligence. Specifically, we describe an early performance robot that caters its joke selection, animation level, and interactivity to a particular audience based on real-time audio-visual tracking. Learning from human signals, the robot will generate performance sequences on the fly.

Keywords

Audience Tracking, Human Robot Interaction, Online Learning, Entertainment Robots

ACM Classification Keywords

D.2.11. Domain-specific software architectures, J.5 Computer applications in the Fine and Performing Arts

General Terms

Work-in-progress paper

Introduction

Robot theater is a rich new arena for developing and evaluating interaction capabilities between machines

Copyright is held by the author/owner(s).

TEI '11, Work-in-Progress Workshop

Jan 23, 2011, Madeira, Portugal.

and humans ([1][2]). It provides a constrained environment rich in data and attractive to general population feedback. By creating audience sensing technologies that can help a robot parse crowd response and developing more effective emotive, communicatory and animation capabilities for the robot itself, we hope to accelerate innovation in social robotics on and off the stage as well as to create new forms of expression and collaboration for human performers.

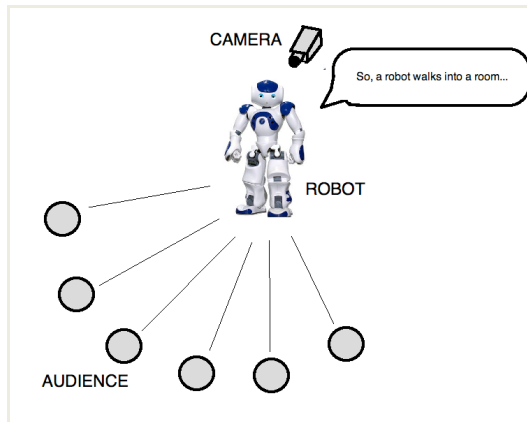

figure 1. Setup: Robot on stage with camera, facing audience

To this end, we have created a first-pass performing robot (Fig. 1) based on the Nao platform, that caters its jokes, animation level and interactivity (e.g. soliciting information from the audience) to individual audiences using online learning techniques, as in [9].

Background

Storytelling is a central facet of being human. It is common to spend much of our free time watching movies, sharing gossip and reading the newspaper. If robots are to integrate into everyday life, charisma will play a key role in their acceptance. Their embodied presence and ability to touch and move around in the physical world allows us to communicate with them in novel ways which are more naturally human [4]. We believe that Robot Theater can provide a valuable stepping stone to creating impactful robotic characters.

Various forays have been made into the topic of robotic performance, including ([1][3][6][7]). The key addition in this project is the integration of intelligent audience sensing, which allows conscious and subconscious human behaviors to motivate live performance generation. In this process, we transform the theater into a valuable arena for interaction research.

Because of this unique approach, our work extends and begins to answer Breazeal's call to action in [1]:

"The script places constraints on dialog and interaction, and it defines concise test scenarios. The stage constrains the environment, especially if it is equipped with special sensing, communication or computational infrastructure. More importantly, the intelligent stage, with its embedded computing and sensing systems, is a resource that autonomous robotic performers could use to bolster their own ability to perceive and interact with people within the environment"

Informal post-performance surveys from Knight's previous work with the robot have helped inform the

behavioral design of the current joke choreographies. In August 2010, Knight implemented the predecessor to the standup comic presented here on the same physical robot [8]. The series was called 'Postcards from New York' and was displayed publicly to strangers in Washington Square Park, coinciding with professional lunch breaks. Though individual comedy sketches were preset, visitors (including students, professionals and tourists, both adult and children) were invited to choose the topic by selecting a Postcard, then showing it to the robot. Upon recognizing the Postcard, the robot would go on to perform a two-minute long sketch relating to its 'personal experiences' in that neighborhood. Viewers enjoyed its humor and physical form, but were very sensitive to sound quality. Their almost universal favorite feature was seeing the robot move, so we animate all the jokes in this series and will also amplify its sound.

System Overview

In the software we are developing now (see Fig. 2), the robot caters its jokes and joke sequence to viewers using online learning techniques. Individual jokes have labeled attribute sets including: topic, length, interactivity, movement-level, appropriateness and hilarity. As the robot is telling a joke, we aggregate the sensor data, categorizing the total enjoyment at the end of the joke as positive or negative on a -1 to 1 scale. Using that number, the Audience Update reweights its model of what the audience likes and dislikes based on the attributes present in the last joke, increasing those weights if the response was good and visa-versa. The Joke Selector then finds a best match joke given the latest audience model, also accounting for the current story phase desired. The process iterates until the show is done.

We have a scheduled performance coming up for TEDWomen in Washington DC on December 8, 2010. As of this paper's submission date, we will direct an on-stage microphone and high-resolution camera toward the audience to collect the audio and video data. To aid the latter, we will also distribute red-green indicator paddles among attendees, which gives them an explicit modality for communication in expressing approval and

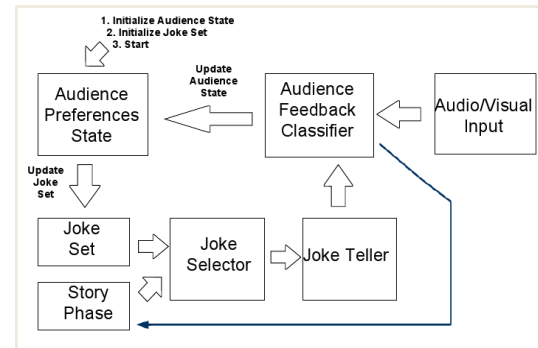

figure 2. System for Online Joke Sequencer

disapproval, or if the robot asks them a question. Previous to that, we are testing our system locally at Carnegie Mellon lecture halls, gathering audio data unobtrusively during live presentations and performances, and testing vision capabilities using ourselves and friends.

Software Architecture

Because our application scenario is in a large lecture hall, we decided to use an external HD camera and microphone to improve the resolution of our data collection. As displayed in Fig. 3, the robot stores the

full set of jokes and corresponding animations in his head, awaiting computer command via wifi. Off-board, communication between modules is moderated by a mother python script and shared data files.

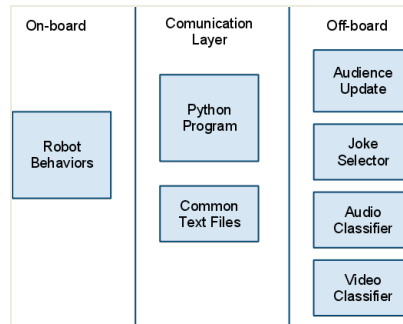

figure 3. Software Architecture

On-board Robot Behaviors

A library of possible jokes and animations are pre-loaded onto the robot. An individual joke will trigger when the robot receives its respective 'joke id' from the communication layer. If communication breaks down between jokes, there is also a timeout behavior in which it will automatically forward to a randomly picked next joke. If time permits, we could also add stalling capabilities, where it pretends to drop something or smoke a cigarette while waiting for communication to resume.

Sample Joke:

"Waiter! Waiter! What's this robot doing in my soup?"
 "It looks like he's performing human tasks twice as well, because he knows no fear or pain."

Audio-Visual Audience Feedback Classifier

The goal of the audience feedback classifier is to determine how much the audience is enjoying the robot comedian's performance at any given time using a weighted combination of the sensor data. This is the central module of the project, as it highlights the new possibilities for feedback and interaction in the space of robot-audience interaction and tracking. We are beginning with a small subset of all possible audience sensors, evaluating the relevance weights of each by training Support Vector Machines [10] on hand-labeled data, a technique that is extensible to various future sensors. The output of this module will be a real-valued number on the interval $[-1, 1]$. An output of 1 represents a "maximum enjoyment" classification. An output of -1 indicates a "minimum enjoyment" prediction.

Real-time Vision Module

The current system allows the audience to give direct yes/no feedback by holding up a colored paddle (red on one side and green on the other). During high interactivity settings, the robot might prompt the audience to answer a question that requests information (yes/no) or valence (like/dislike).

Real-time Audio Module

In contrast to the explicit response targeted above, the audio captures meaning about the audience's ambient response in the form of laughter, applause or chatter and is the highest weight feedback mode for the upcoming performance. A simple baseline metric assumes that all audio feedback from the audience is positive (i.e., only laughter and applause, no booing or heckling) and measures the duration and amplitude (volume) of the audio track to predict a level of

enjoyment. We are also computing amplitude, time and frequency spectrum statistics on test auditorium recordings to further refine our estimates.

Audience Model Update

Our current model assumes that the joke attributes are known. Thus, the purpose of this module is to use the audience's enjoyment-level of the previous joke to update the robot's estimates of what attributes the audience likes and dislikes. In mathematical terms, we use a technique called online convex programming [10]. We use the previous audience estimate, as summed up by the weight vector $w(t)$, and increase or decrease each attributes' value by multiplying the valence of the response, y , with the characteristics of the previous joke $J(t)$ and a learning-rate constant α . Thus audience model is updated to the next timestep, $w(t+1)$, using the equation below:

$$w(t+1) = w(t) + \alpha y J(t)$$

Joke Selector

The simplest way to select the next joke is to use the latest audience model to find joke that maximizes the "enjoyment score" based on individual joke attributes, by taking the dot product of the two. This technique aggregates all the possible aspects of each joke that the audience may like or dislike and chooses the one with the best score.

Exploration versus Exploitation

One danger of the above technique is that if the robot finds one successful set of attributes, it will not continue to try out other subjects or performance modes that the audience might also enjoy. We suspect the audience will appreciate diversity of performance,

thus, we are also incorporating a bandit algorithm strategy in which we will blindly choose a new joke, every so often, particularly toward the beginning of the set. This is called the 'epsilon-decreasing strategy' because the probability of choosing the best scored joke is $1-\epsilon$, where ϵ decreases over time [10].

Generating a Joke Sequence

A natural extension to the single next-joke selector is to generate a coherent joke sequence. Proposed solutions to this challenge thus far include: creating coherent joke groups and/or modeling a performance histogram. In the former, the audience model would be used to select and sequence several jokes at a time, though still exiting early in the case of dramatic failure (very low audience enjoyment score). In the latter, instead of just looking for a single best-fit joke, we look for the best-fit current story phase joke, e.g. Phase I: Grab Attention, Phase II: Interstitial and Phase III: Climax, (using a simple Markov model to decide when to transition between them).

Metrics for Success

This project presents an early realization of a robot performance with an emphasis on real-time audience tracking, personalization, and live performance generation. We will judge the system successful if it realizes the following:

- Real time integration of sensing, processing and actions.
- Domain knowledge of the audience tracking feature set: exploring and discarding sensing modalities based on the added value to the system's effectiveness.

- Improved enjoyment levels for the proposed system versus a randomly-sequenced control

Conclusion and Future Work

In our case, the metaphor of robotic theater has already served to develop algorithm concepts that apply directly to everyday robotics research. For example, we plan to adapt this software to a tour-guide robot that will individualize the sequence, style and content of its tours based on self-supervised audience tracking as part of an autonomous robots initiative here at CMU. It will incorporate online sequencing of content and some forms of spontaneous interaction, which is novel for robotic guides, although [5] does propound the importance of non-verbal interaction. Such experience validates the claim Demers makes in his survey paper motivating robot performance [2]:

"By combining AI with Theatre, new questions will be raised about how a presentation of an experiment from an AI lab can differ from a theatre presentation of the same machine. Researchers from these disciplines operate from different perspectives; art can become the "new" experimental environment for science because the world does not only consists of physical attributes but also of intangible realities."

In follow-up projects, we hope to partner with and learn from those in the arts community. By adding a model of performance attributes to the overall system diagram, we could begin to evaluate the success of the robot's delivery. Parameters might include: tone of voice, accent, costuming, props, gestures, timing, LED illumination and pose. In this process, we are beginning to translate human behavior into rules a machine can understand. Ultimately, Knight hopes to

extend these learnings to full theatrical performances, deepening the understanding of character, motivation, and, even, relationships with other robotic or human actors on stage. The work has only just begun.

Acknowledgements

Thanks go to our Statistical Methods for Robotics Professor Drew Bagnell and TA Felix Duvallet.

References and Citations

- [1] Breazeal, C., et al. Interactive Robot Theatre. *Comm. of ACM*, (2003), 76-85.
- [2] Demers, L. Machine Performers: Neither Agentic nor Automatic. *HRI Workshop on Collaborations with Arts*, (2010).
- [3] Hoffman, G., Kubat, R. A Hybrid Control System for Puppeteering a Live Robotic Stage Actor. In *Proc. RoMan 2008*, (2008), 1-6.
- [4] Knight., H. et al. Real-time social touch gesture recognition for sensate robots. In *Proc. IROS 2009*, (2009), 3715-3720.
- [5] Kobayashi, Y., et al. Museum guide robot with three communication modes. *IROS 2008*. (2008) 3224-3229.
- [6] Lin, Chyi-Yeu, et al. The realization of robot theater: Humanoid robots and theatric performance. In *Proc. ICAR 2009, Advanced Robotics* (2009), 1-6.
- [7] Murphy, R., Hooper, A., Zourntos, T. A Midsummer's Night Dream (with Flying Robots). *HRI Workshop on Collaborations with Arts*, (2010).
- [8] Postcards from New York http://www.marilynmonrobot.com/?page_id=197.
- [9] Sofman, B. et al. Improving robot navigation through self-supervised online learning. *Journal of Field Robotics*, (2006), Vol 23, 1059-1075.
- [10] Thrun, S., Burgard, W, and Fox, D. *Probabilistic Robotics*. The MIT Press, (2005).

Energy Conservation and Interaction Design

Keyur Sorathia

Assistant Professor,
Dept. of Design,
IIT Guwahati.
keyur@iitg.ernet.in

Abstract

Bringing attention to critical issues through fun, playful yet informative way is a challenge in Interaction Design. In this paper, we describe one design module exercise focusing on creating awareness to energy efficiency and conservation through interactive installation. It showcases design ideas and methods, few initial concepts and learning during the module.

Keywords

Energy efficiency and conservation, awareness, interactive installation, new interaction techniques

ACM Classification Keywords

H.5.2 User Interfaces, Input device & strategies D.2.2 Design Tools and Techniques, User Interfaces D.2.6 Programming Environments, Interactive Environments D.2.10 Design, Methodologies

General Terms

Design, Experimentation.

Introduction

With the growth of economy, the demand for energy has grown substantially. The demand for energy is growing manifold and the energy sources are becoming scarce and costlier [1]. Furthermore, the high level usage of energy intensity in some of the sectors is a matter of concern. India is presently the sixth greatest electricity generating country and account for 4% of

the world's total annual electricity generation. India is also currently ranked sixth in annual electricity consumption, accounting for about 3.5% of the world's total annual electricity consumption.

In such a scenario efficient use of energy resource and their conservation assume tremendous significance and are essential for curtailment of wasteful consumption and sustainable development [2].

As a starting point, our approach is to focus on a specific segment of energy conservation, which is electricity efficiency and wastage. We introduced a design module focused on creating awareness of electricity consumption, efficiency and reduce wastage through interactive installation. The module aimed at designing an interactive installation that can create awareness about the specific topic through new interaction techniques.

Here, we present introduced design module, designed examples and learning through the module.

Background

There are significant amount of efforts happening by Bureau of Energy Efficiency (BEE) including several activities and events such as bachat lamp yojana [3], national educational awareness programs, state level painting competitions in schools, conferences, online tips for energy conservation in domestic environment [4], training programs and many more. Additionally, few state government electricity boards distribute paper materials to people in villages, towns etc.

The key problems in these forms of awareness are illiteracy/semi literacy, sometimes boring textual formats and inability to reach appropriate audience. There is an essential need of designing a system that

can reach larger audience overcoming barriers such as literacy, age group, distance and ability to reach to more number of villages and towns.

Introduced designed module

We look at existing programs around; we realize that the problem is not just limited illiteracy or age group or distance, but also fun, playful and engaging element through which the messages have been conveyed.

The module is introduced with an objective

- * To design an interactive installation that can work as standalone communicative element as well as an integrated part of a larger exhibition.
- * The information is in the context of electricity usage in home environment.
- * As the installation will have to reach to the widest possible group of people overcoming above mentioned barriers, interaction modalities have to be chosen carefully and needs to be engaging and playful installation.

The designed projects are focused on showcasing different ways of energy conservation, use of energy efficient appliances etc. in fun, playful and interactive way. The installation should not be only be engaging to visitors, but also showcase relevant information to the home context. Installation should be designed in such a way that it can be carried to different places and can be a part of a larger exhibition later on.

Students are given specific keywords: energy conservation, interactive installation, awareness, engaging, playful, stand alone, prototyping, tangible interfaces.

The design module also aims at nurturing the imagination towards new interaction [5] techniques and more tangible installations. By constraining the theme to electricity conservation & efficiency, we encouraged

students to think about small yet important issues such as standby power, use of energy efficient appliances, and use of sun light etc. Students are also encouraged to use creative representation of the data. For example, instead of showing power wastage in unit format, it can be shown in money format so people can relate power wastage directly with money wastage. This can help users to relate the electricity wastage with known facts such as money wastage, deforestation etc. Though the theme is restricted to electricity usage in home environment, students are encouraged to research and ideate in other areas for better understanding of energy conservation. The module is conducted among 15 students of final year Bachelors in Design, dividing them into 5 groups with 3 students each for 26 days

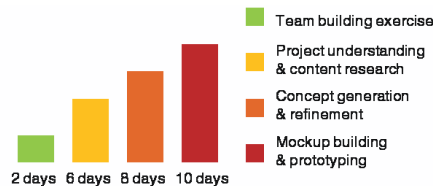

figure 1. Graphical representation of day wise structure of design module.

The module starts with a small fun exercise on team building to build a good understand among group members. It is followed by few sessions on understanding energy conservation, existing work & projects and mainly to understand the domain of interactive installation. Due to non technical background of students, maximum numbers of days are given to prototyping.

Results

Content understanding and ideas are noted down through mind maps and storytelling. We found that mind mapping and storytelling helped students to explore wide varieties of design ideas from tangible installations to screen based installation. Here, we present some of the initial design ideas highlighting varied range of solution.

Dancing Puppet (fig 2a.)

People have tendency not to switch off the main power supply in tv, computers, CD players etc. wasting ample amount of electricity through putting these appliances on standby mode. Dancing puppet (fig 2a.) explores the term of "standby power". The idea is aimed at bringing people's attention to electricity wastage due to standby power. 3 main buttons having ON, STANDBY, OFF icons are showcased. Pressing ON & OFF makes puppet dance & sleep respectively. Pressing STANDBY makes puppet to dance a little, indicating small but unavoidable wastage of electricity. A dancing puppet is used as a metaphor to convey specific information.

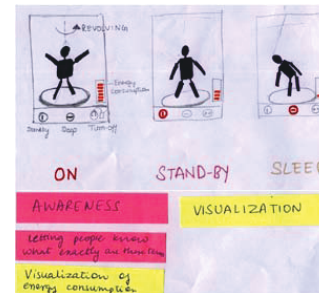

figure 2a. A designed idea showing puppet dancing, moving

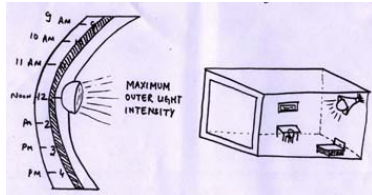

figure 2d. Showcases the idea to motivate the use of daylight to save electricity. Slider with Sun metaphor at 12.00 noon.

Recycle trash (fig 2e.)

In addition to electricity conservation, ideas are presented to encourage the use of recyclable products. Recycle trash (fig 2e.) is aimed at encouraging use of recycle products and to encourage the use of trash bins. Once paper trash is thrown into the trash bin, it creates a recycling sound and gives a recycled paper bag with a energy conservation message written on it. The critical issue of the use of recycled products is presented through a fun activity.

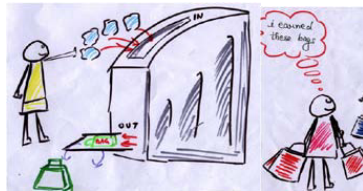

figure 2e. People throwing trash inside the bin and a recycled bag comes out

I WILL (fig 2f. and fig 2g.)

I WILL is aimed at motivating people for resolutions such as I will reuse, I will recycle, I will save power etc. The idea is expressed through a simple quiz asking

people to place iconic cubes on the table to fill the incomplete sentences. A person's silhouette is presented as "I" and "WILL" written on the wall. The incomplete sentences are projected on the wall after "I WILL". The projected surface has incomplete sentences as a part of quiz that asks people to use iconic cubes to complete the sentence. Right answers are indicated through smiley and sound. LED trigger is indicated asking the person to place himself instead of silhouette. Once the person places himself on silhouette, camera is triggered to take a picture that is followed by a print of complete sentence. For example, I (person's picture) WILL REUSE. This allows a new print every time with a different person.



figure 2f. I WILL installation with silhouette, WILL & projection of a quiz



figure 2g. Person keeping relevant cubes to complete the quiz

These ideas are currently into prototyping phase

Learning

The design module leads to creative discussions in forms of mind maps and alternative ways of data representation. One clear observation was that mind map helps exploring the contents in keywords format that leads a narrowed focus to the context, eventually nurturing design decisions. Discussion included usage of relevant metaphors suitable to the context, metaphors that can convey message in simplistic yet entertaining manner, its relevance to everyday activities and different interaction modalities.

The aim of these ideas is to engage people for 45 seconds to 1 min and inform them about critical issues of electricity conservation. Design explorations indicated that adding contents and features to the installation would not have helped convey the message well; instead a good idea is to focus on a single message and present it through a meaningful way. Additionally we found that using tangible metaphors in the installation will involve more engagement to the installation than just a screen based solution. It was also found that students designed wide varieties of solution in different interaction modalities, ranging from gestures, sliders, tangible metaphors to screen based solution and representation techniques ranging from a smiley, money metaphor, recycled gift to a simple text based message.

Conclusion

We feel that this design module is helpful as an exercise to encourage rethinking energy conservation, new interaction techniques and different ways data representation. We have tried to show that awareness

about energy conservation need not to be always through advertisements, paper sheets etc. but it can be a playful learning activity and can engage wide variety of audience. Due to the time constraint, we had to limit the number of days to understand energy conservation; more time to domain understanding would have helped nurture our design decisions.

This design module adds a new angle to existing design exercise [6] by concentrating more on different interaction techniques and alternative ways of representation.

Acknowledgements

We thank all the students of Interactive Communication Project class at Indian Institute of Technology – Guwahati.

Example citations

- [1] Bureau of Energy Efficiency www.bee-india.nic.in/
- [2] Resources to save energy <http://www.saveenergy.co.in/resources.php>
- [3] Bachat Lamp Yojana <http://www.beeindia.nic.in/content.php?id=2>
- [4] Tips for energy conservation for domestic http://www.bee-india.nic.in/useful_downloads.php
- [5] Angela Chang, James Gouldstone, Jamie Zigelbaum, Hiroshi Ishii "Simplicity in Interaction Design" Proceeding of TEI'07, 15-17 Feb 2007, Baton Rouge, LA, USA, ACM Press (Feb 2007)
- [6] Harrison, S. and Back, M. (2005) "It's Just a Method': A Pedagogical Experiment In Interdisciplinary Design" Proceedings of CHI 2005, alt.chi, Portland, OR, ACM Press, April 2005.